

Door compartment

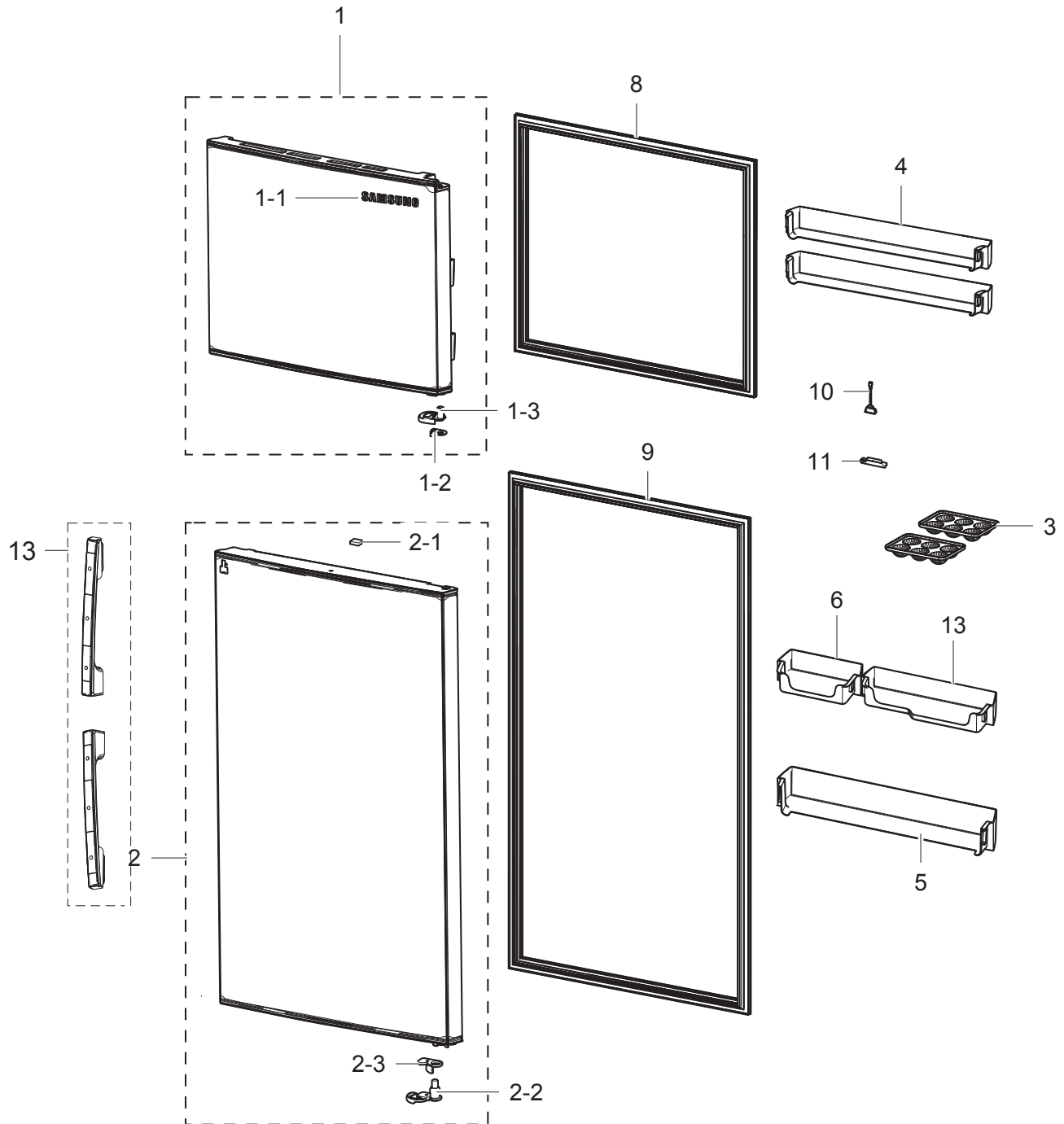

PART LIST OF DOOR : RT53K6100S8/ZA

No.	Code No.	Lvl.	Loc.	Description	Specification	Qty	SA/SNA
1	DA91-04144Y	2	M0063	ASSY DOOR FOAM-FRE	RT6000,RT53,S8,BAR,NO	1	SA
1-1	DA64-04020A	3	M0196	MASCOT	ALL,Ni,L80	1	SA
1-2	DA71-40137A	5	A0597	STOPPER-DOOR	STS304,T2.0,T2.0	1	SA
1-3	DA63-06734B	5	-	GROMMET HINGE-FRE LOW	RT-H530G,POM,BLACK	1	SA
2	DA91-04140Y	2	Z1100	ASSY DOOR FOAM-REF	RT6000,RT53,S8,BAR	1	SA
2-1	DA61-03769B	4	A0534	MAGNET	SVETA,FERRITE,1600Gauss	1	SA
2-2	DA61-00589B	4	Z2014	STOPPER DOOR-REF LOW	TT-PJT,NO-DIS,POM,W	1	SA
2-3	DA61-09633A	4	-	STOPPER-REF	3050-2,PO-SPHC,T4.0	1	SA
3	DA63-07346A	3	A0656	TRAY EGG	3050,GPPS,HB,TP BLUE,165N,HI-IM	2	SA
4	DA63-07697A	3	A0711	GUARD-FRE	RT53/RT50,GPPS,TP BLUE	2	SA
5	DA63-07701A	3	A0713	GUARD-JUMBO	RT53/RT50,GPPS,TP BLUE	1	SA
6	DA63-07388A	3	-	GUARD-VARIETY1	3050,GPPS,T3,TP BLUE,380	2	SA
8	DA97-13921H	2	-	ASSY GASKET-FRE	RT53/RT50,GRAY,W728,L502	1	SA
9	DA97-13921J	2	-	ASSY GASKET-REF	RT53,GRAY,W730,L1162	1	SA
10	DA67-02385M	4	-	CAP DOOR SWITCH	3050-PJT,PP,T1.5,HB,BJ75	1	SA
11	DA34-00043J	4	-	SWITCH REED	UL1007 AWG 22,50mm	1	SA
12	DA97-19775A	2	A0553	ASSY HANDLE	RT53/50/46/43,LIGHT DOI META	1	SA
13	DA63-07699A	3	0	GUARD-REF	RT53/RT50,GPPS,TP BLUE	2	SA

Freezing compartment

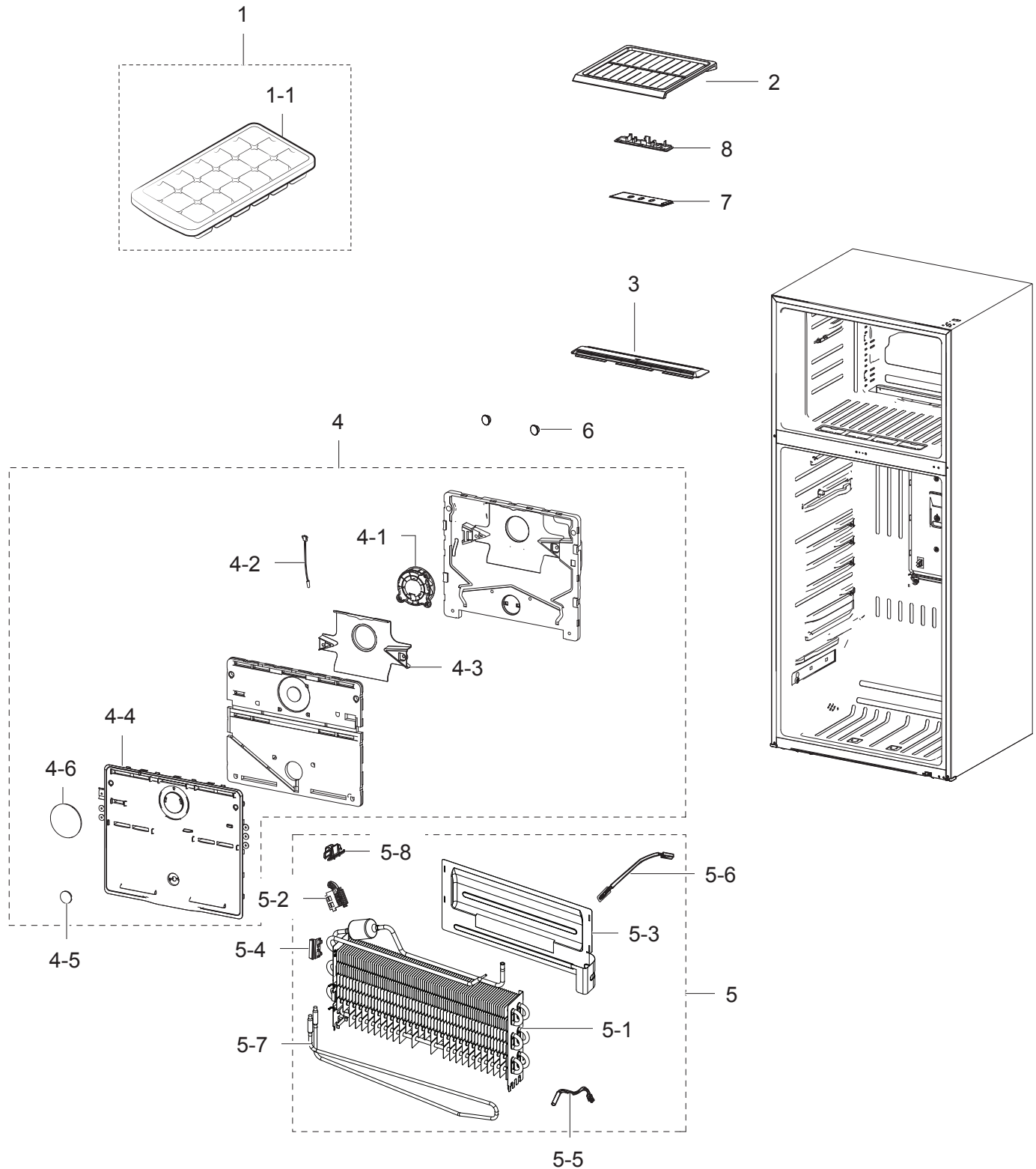

PART LIST OF FREEZER : RT53K6100S8/ZA

No.	Code No.	Lvl.	Loc.	Description	Specification	Qty	SA/SNA
1	DA90-09630C	1	A0104	ASSY ICE MAKER	RT50/53, TRAY	1	SNA
1-1	DA63-01883B	2	A0120	TRAY ICE	TS1-PJT,PP,-,-,-,-,NATURAL,-	1	SA
2	DA67-04175A	2	-	SHELF-FRE	RT6000K,GPPS,TP BLUE	1	SA
3	DA63-07355A	2	A0756	COVER-AIR FRE	RT380/350,PP,COOL WHITE	1	SA
4	DA97-16255N	2	M0303	ASSY COVER EVAP-FRE	RT6000K 43/46/50/53,	1	SA
4-1	DA31-00338A	3	-	MOTOR BLDC FAN1	92mm Box-Fan Motor,3350±7	1	SA
4-2	DA32-00070A	3	A1018	SENSOR TEMP1	SC41198-021A,900mm,13.2kohm	1	SA
4-4	DA63-08318J	3	-	COVER EVAP-FRE	RT6000K 43/46/50/53,PP,HB	1	SA
4-5	DA64-04412A	3	A0760	KNOB-DIAL	3050,HIPS,2.0,COOL WHITE,TMF	1	SA
4-6	DA63-08326B	3	-	COVER-TWIN COOLING	GPPS,HB,GENTLE BLUE,S	1	SNA
5	DA96-01038N	2	A0163	ASSY EVAP-FRE	RT6000K,220V,PLATE HEATER,	1	SA
5-1	DA59-00588B	3	-	EVAPORATOR-FRE	Fin Tube,RT6000K_RT50,53,	1	SNA
5-2	DA61-00603A	3	T0066	FIXER SENSOR1	n-PJT,PP,T2,NATURAL,HB,BJ75	1	SA
5-3	DA61-09621A	4	-	PLATE EVAP-RIGHT	RT-H530G,AL,T0.4,A1100P	1	SNA
5-4	DA61-07411A	3	A0744	FIXER-FUSE	NW2,PP,NATURAL,BJ750	1	SA
5-5	DA32-00066B	3	A1018	SENSOR TEMP2	-,TWIN,-50~80°C,5V,-,-,PBA CA	1	SA
5-6	DA47-00301F	3	A1008	THERMO FUSE-ASSY	AC250V,10A,109~110°C,S.O	1	SA
5-7	DA47-00460F	3	A0921	HEATER METAL SHEATH	AC230V,3050 TMF, 330	1	SA
5-8	DA61-07410A	3	G0205	FIXER-HEATER FRE	NW2,PP,NATURAL,BJ750	2	SA
6	DA67-30266K	2	-	CAP SCREW	A-TOP,PP,T1.5,HB,BJ750,COOL WH	3	SA
7	DA41-00519R	2	G0090	ASSY LAMP LED2	3ea,CEM-1,FR-4 65*10*1.6T,	1	SA
8	DA63-07368A	2	A0490	COVER-LAMP	3050,GPPS,T2,TP BLUE,G116HV	2	SA

Fridge compartment

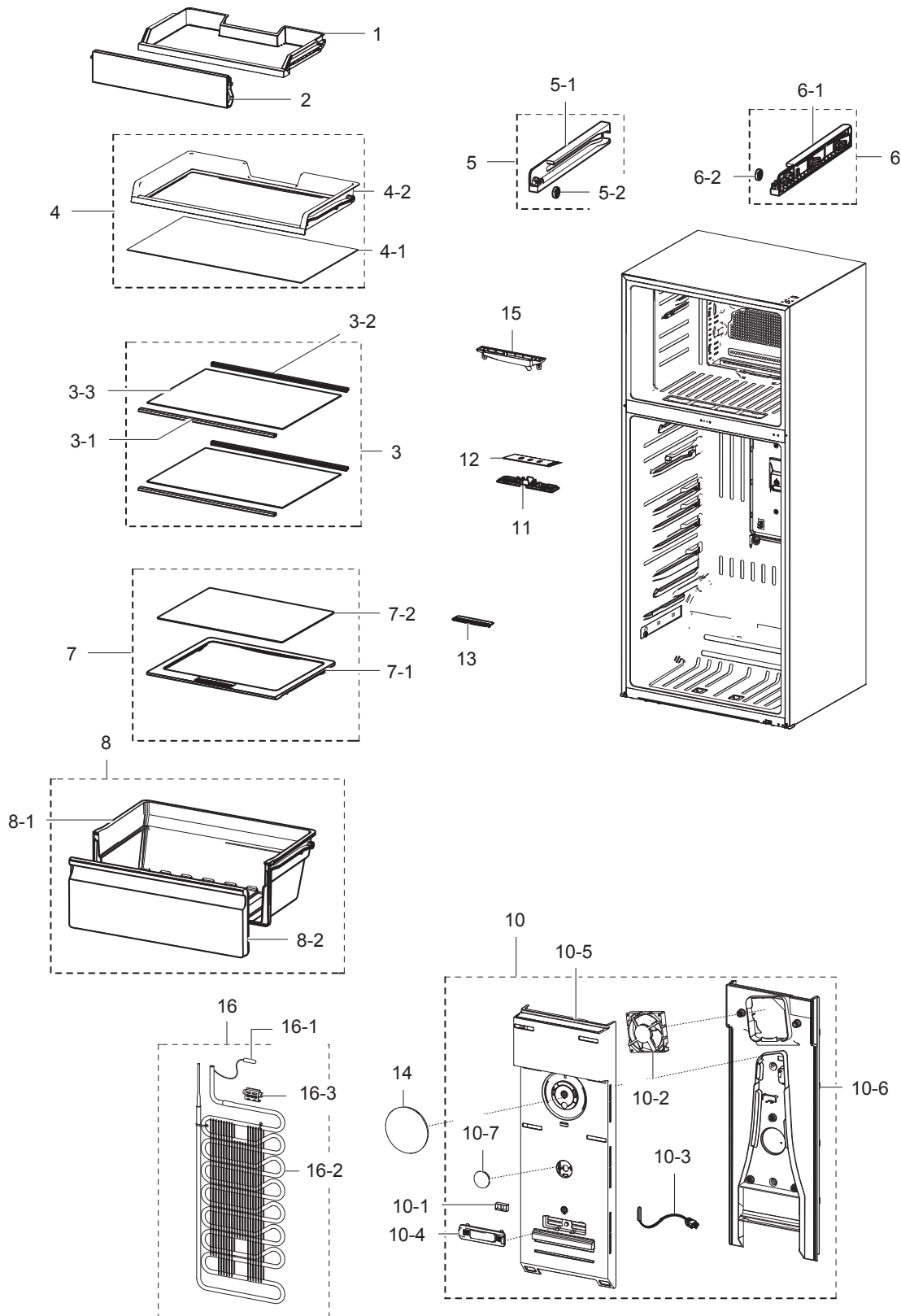

PART LIST OF FRIDGE : RT53K6100S8/ZA

No.	Code No.	Lvl.	Loc.	Description	Specification	Qty	SA/SNA
1	DA63-08328A	2	-	TRAY CHILLED ROOM	RT53,GPPS,T2.5,HB,TP B	1	SA
2	DA63-07691B	3	-	COVER TRAY-CHILLED	RT53/50,GPPS,T2.5,HB,	1	SA
3	DA97-16274E	2	-	ASSY SHELF GLASS-REF	RT6000K,RT53/50,Las	2	SA
3-1	DA64-04280D	3	-	TRIM SHELF-REF FRONT	RT 50/53,ABS,SV-015	2	SNA
3-2	DA64-04634K	3	-	TRIM SHELF-REF REAR	RT50/53,ABS,SV-0157,	2	SNA
3-3	DA64-04990A	3	-	GLASS-SHELF REF	RT6000_53/50,GLASS,T4,67	2	SNA
4	DA97-16279A	2	-	ASSY SHELF SLIDE-REF	RT6000_53/50	1	SA
4-1	DA64-04989A	3	-	GLASS-SHELF REF SLIDE	RT6000_53/50,GLASS	1	SNA
4-2	DA67-04174A	3	-	SHELF SLIDE	RT53,HIPS,COOL WHITE	1	SNA
5	DA97-14368B	3	-	ASSY RAIL-LEFT	3050-2,COOL WHITE	2	SNA
5-1	DA61-09581A	4	-	GUIDE RAIL-L	RT H530/500/460/430G,HIPS,C	2	SNA
5-2	DA66-10104A	4	-	ROLLER-FRE	POM,D22,NATURAL	2	SC
6	DA97-14369B	3	-	ASSY RAIL-RIGHT	3050-2,COOL WHITE	2	SNA
6-1	DA61-09582A	4	-	GUIDE RAIL-R	RT H530/500/460/430G,HIPS,C	2	SNA
6-2	DA66-10104A	4	-	ROLLER-FRE	POM,D22,NATURAL	2	SC
7	DA97-14341C	2	A0181	ASSY COVER VEG	RT6000K,RT53/50	1	SA
7-1	DA63-07700A	3	A0210	COVER VEG	RT53/50,HIPS,-,COOL WHITE,ATEC	1	SNA
7-2	DA67-03645Y	3	0	GLASS-SHELF REF LOW	GLASS	1	SNA
8	DA97-14336B	2	M0300	ASSY CASE VEG-LOW	RT50/53,UAE	1	SA
8-1	DA61-09579A	3	-	CASE VEG-LOW	RT53/50,PP,COOL WHITE,BJ750	1	SNA
8-2	DA63-07698A	4	-	COVER VEG-FRONT LOW	RT53/50,GPPS,HB,TP B	1	SNA
10	DA97-16256X	2	Z1177	ASSY COVER EVAP-REF	RT6000K,RT43/46/50/5	1	SA
10-1	DA02-00216B	3	-	CATALYST-DEODORIZER	T10,W15,L30,3050 TMF	1	SA
10-2	DA31-00338A	3	-	MOTOR BLDC FAN2	92mm Box-Fan Motor,3350±7	1	SA
10-3	DA32-00070B	3	A1018	SENSOR TEMP3	SC41198-021A,500mm,13.2kohm	1	SA
10-4	DA63-07423A	3	-	COVER-DEODORIZER	3050,PP,COOL WHITE	1	SA
10-5	DA63-08319F	3	-	COVER EVAP-REF A	RT6000K,PP,HB,COOL WHIT	1	SNA
10-6	DA63-08324B	3	-	COVER EVAP-REF B	RT43/46/50/53,PP,HB,BLA	1	SNA
10-7	DA64-04412A	3	A0760	KNOB-DIAL	3050,HIPS,2.0,COOL WHITE,TMF	1	SA
11	DA63-07368A	2	A0490	COVER-LAMP	3050,GPPS,T2,TP BLUE,G116HV	2	SA
12	DA41-00519B	2	G0090	ASSY LAMP LED1	5ea,CEM-1,100*20,WHITE,SMA	1	SA
13	DA63-07341B	3	-	COVER SHEET	3050-PJT,HIPS,COOL WHITE,S83	1	SA
14	DA63-08326B	3	-	COVER-TWIN COOLING	GPPS,HB,GENTLE BLUE,S	1	SNA
15	DA61-09620B	4	-	PLATE DRAIN	RT43,Al,T0.3,A3003-H12	1	SNA
16	DA96-01229A	2	A0184	ASSY EVAP-REF	RT6000K,BARE TUBE,AL	1	SA
16-1	DA32-00070C	3	A1018	SENSOR TEMP4	SC41200-021A,250mm,11.73kohm	1	SA
16-2	DA59-00605A	3	-	EVAPORATOR-REF	Fin Tube,RT6000K,1,AL,7,B	1	SNA
16-3	DA61-00453A	3	-	FIXER SENSOR2	A-TOP,EVAP,PP,NTR,BJ750,ALL	1	SA

Cabinet compartment

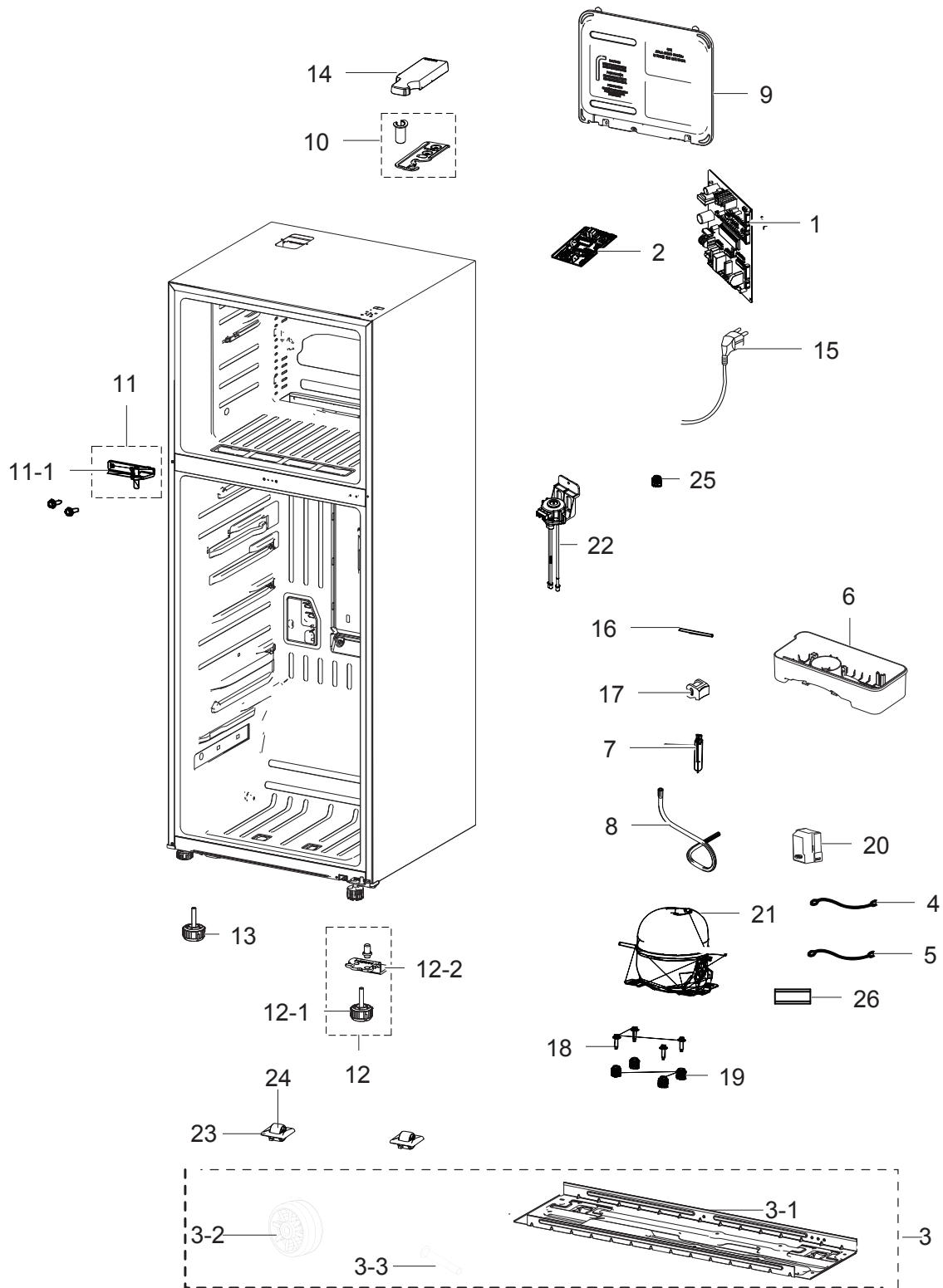

PART LIST OF CABINET : RT53K6100S8/ZA

No.	Code No.	Lvl.	Loc.	Description	Specification	Qty	SA/SNA
1	DA92-00853D	1	A0952	ASSY PCB MAIN	TWIN COOLING,RT6000K,160*1	1	SA
2	DA92-00459E	1	-	ASSY PCB INVERTER	INVERTER,3050,148*98.5	1	SA
3	DA97-14356A	2	A0526	ASSY CHASSIS COMP	3050-II (RT-H530G),CASTE	1	SA
3-1	DA64-04656A	3	A0739	CHASSIS COMP	3050-II (RT-H530G),GI-SGCC,-,	1	SNA
3-2	DA61-40126B	3	A0527	CASTER-REAR	REF-ALL,PP,NATURAL	2	SA
3-3	DA60-90146A	3	A0861	PIN-CASTER	SR-289-429,MSWR,L38,ZPC2	2	SA
3-4	DA71-50240B	3	A0612	BRACKET-CABI	TSE MODEL,GI-SGCC,T1.6	4	SNA
3-4-1	0101-002938	4	A0699	STEEL PLATE	GI,SGCC,1.6mm,Z14,NC	14	SNA
4	DA39-20389A	2	A0562	ASSY WIRE HARNESS-EARTH	EARTH,ALL,,,,,FR	2	SA
5	DA39-20389A	2	A0562	ASSY WIRE HARNESS-EARTH	EARTH,ALL,,,,,FR	2	SA
6	DA97-19114A	2	A0529	ASSY TRAY DRAIN WATER	RT6000K,New Design	1	SA
7	DA62-04309A	2	A0669	DRYER	C1220T-H,L137,SINGLE MOUTH,For	1	SA
8	DA62-04366A	2	0	PIPE SUCTION-CONNECT	RT-H530G,Cu,C1220T-	1	SA
9	DA97-13545F	2	-	ASSY COVER PCB-PANEL	RT29/32/35/38,TWIN	1	SA
10	DA97-13610A	2	A0705	ASSY HINGE UPP	3050PJ,T2.0,380/350	1	SA
11	DA97-14404A	2	-	ASSY HINGE-MIDDLE	RT-H530G,530/500/460/4	1	SA
11-1	DA61-09576A	3	-	HINGE-MIDDLE	RT53,50,PO-SPHC,T4.5,ZPC	1	SNA
12	DA97-13857F	2	M0344	ASSY HINGE-LOW	RT6000K,model RT50/53, NO	1	SA
12-1	DA61-09106A	3	A0577	FOOT-FRONT	RT6000HW,PP,BLACK,PP_SCRAP	1	SA
12-2	DA61-11132A	3	A0247	HINGE-LOW	PO-SPHC,T4	1	SNA
13	DA61-09106A	3	A0577	FOOT-FRONT	RT6000HW,PP,BLACK,PP_SCRAP	1	SA
14	DA63-07711A	2	A0237	COVER HINGE-UP	RT53,50,46,43,PP,HB,BJ750	1	SA
15	3903-001025	2	A0273	POWER CORD-AT	H05VV-F 3x0.75mm2,BLK,GB3F	1	SA
16	DA73-00199C	2	0	PIPE CONNECT	RT5/6/7000K,Cu,OD6.35,T0.6,	1	SA
17	DA97-19113A	3	-	ASSY PIPE IMMERSING	RT6000K	1	SNA
18	6011-001546	2	A0564	BOLT-HEX	M5(P0.8),L16,ZPC(WHT),SWRCH18A,	2	SA
19	DA63-02617A	3	Z1112	GROMMET COMP	USP05,EPDM,OD27.0,BLACK	4	SA
20	DA63-06122A	3	Z1032	COVER RELAY	MSV,MPPO,T2,BLACK,V-0	1	SA
21	MSV4A1AL1R/TT3	2	-	CMP,COMP,REFRIGERATOR,R-600A	0	1	-
22	DA62-04678A	2	-	VALVE STEP	DC12V,MODULE,2WAY,STRAIGHT/ST	1	SA
23	DA61-01729C	3	0	CASE ROLLER VEGETABLE	3050-2,HIPS,COOL W	2	SNA
24	DA66-00885A	2	-	ROLLER-VEG	TD,PP,NTR	2	SA
25	DA63-04555A	3	-	GROMMET-STEP VALVE	Cullinan,NBR,-,-,-,-,-	1	SNA
26	DA62-00960A	2	-	SEAL CUTT-RUBBER	RUBBER,BLACK,T3,W40,L70	2	SA