

1. Freezer

Exploded View

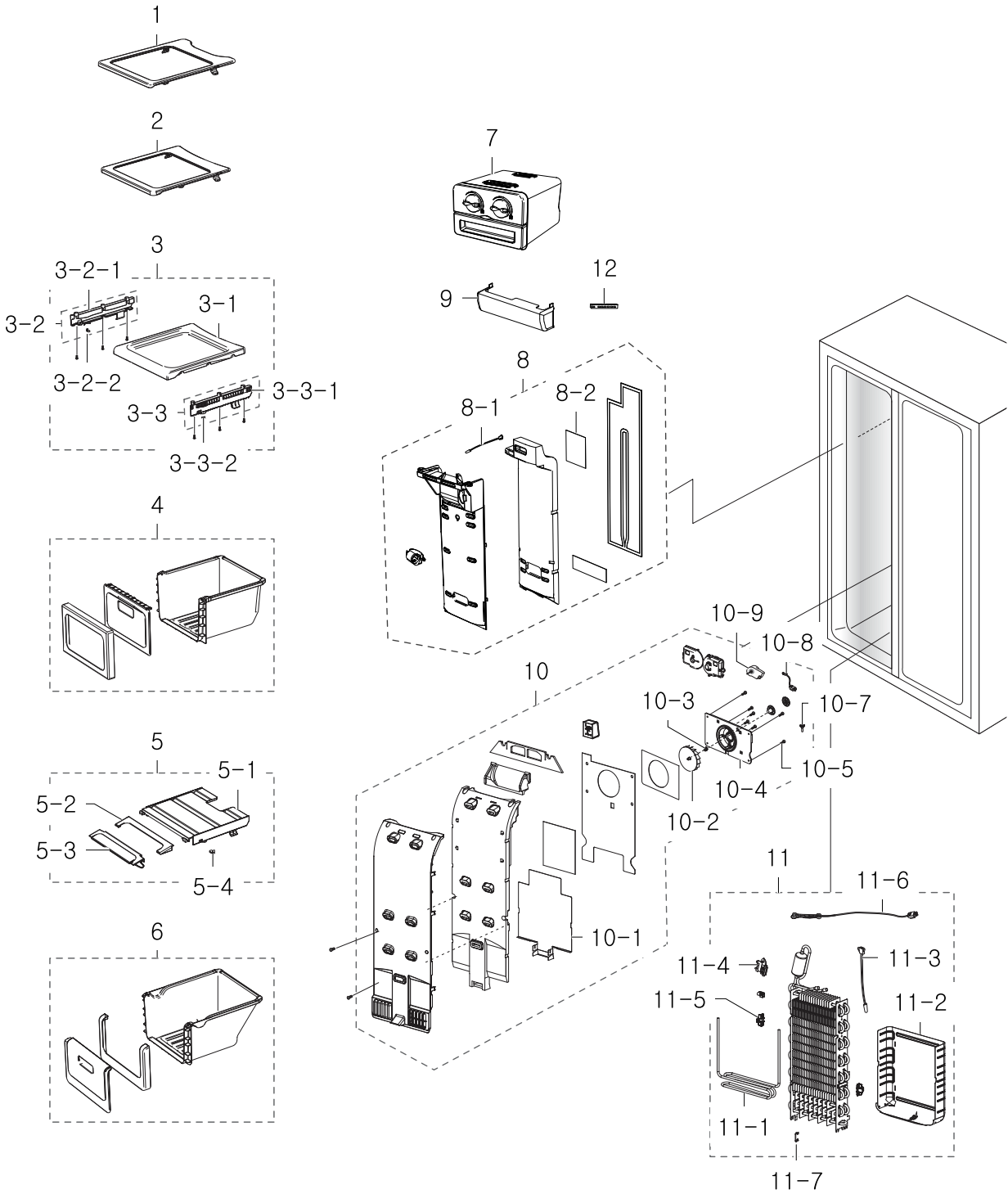

Parts List

No.	Parent	Lvl.	Loc.	Material Code	Description & Specification	SNA	Qty.
1	DA90-03679C	2		DA97-08046C	ASSY SHELF FRE-TOP; HERMES(DISP),HIPS, TE	SA	1
2	DA90-03679C	2	RE064	DA97-08044C	ASSY SHELF FRE-MID; HERMES,HIPS,TEMPERED	SA	1
3	DA90-03679C	2	RF022	DA97-06927A	ASSY-SHELF FRE LOW; HERMES-PJT,-,-,-	SA	1
3-1	DA97-06927A	3	RF360	DA67-02110A	SHELF-FRE LOW; HERMES-PJT,HIPS,-,-,-,COOL	SA	1
3-2	DA97-06927A	3	RR838	DA97-05233B	ASSY RAIL-BOX L; HERMES-PJT,T2.0,W17,L260	SA	1
3-2-1	DA97-05233B	4	RK458	DA61-03413B	RAIL-BOX L; HERMES-PJT,TALC PP,-,-,-,NATU	SA	1
3-2-2	DA97-05234B	4	RK243	DA63-00202C	GROMMET-RAIL; TD-PJT,NY-66,W10.7,L15,COOL	SA	1
3-3	DA97-06927A	3	RR840	DA97-05234B	ASSY RAIL-BOX R; HERMES-PJT,T2.0,W17,L260	SA	1
3-3-1	DA97-05234B	4	RK460	DA61-03412B	RAIL-BOX R; HERMES-PJT,TALC PP,-,-,-,NATU	SA	1
3-3-2	DA97-05234B	4	RK243	DA63-00202C	GROMMET-RAIL; TD-PJT,NY-66,W10.7,L15,COOL	SA	1
4	DA90-05343M	2	RI248	DA97-05047B	ASSY-CASE BASKET HIGH; HERMES,GPPS+HIPS,-	SA	1
5	DA90-05343M	2	RI249	DA97-05049C	ASSY-COVER SLIDE BASKET; HERMES,ABS+HIPS,	SA	1
5-1	DA97-05049C	3	RF450	DA63-03569A	COVER-BASKET LOW; HERMES,ABS,-,-,-,-,TR	SA	1
5-2	DA97-05049C	3	RF057	DA63-03570A	COVER-SLIDE BASKET A; HERMES,HIPS,-,-,-,-	SA	1
5-3	DA97-05049C	3	RF058	DA63-03571A	COVER-SLIDE BASKET B; HERMES,ABS,-,-,-,-,	SA	1
5-4	DA97-05049C	3	RK243	DA63-00202C	GROMMET-RAIL; TD-PJT,NY-66,W10.7,L15,COOL	SA	2
6	DA90-05343M	2	RI170	DA97-05046B	ASSY-CASE BASKET LOW; HERMES,GPPS+HIPS,-,	SA	1
7	DA90-05747D	2	RM001	DA97-05071B	ASSY ICE MAKER-MECH; HERMES,-,-,-,-,-	SA	1
8	DA90-05939B	2	RF439	DA97-05063D	ASSY-COVER MULTI FRE; HERMES09,DISP	SA	1
8-1	DA97-05063D	3	RR337	DA32-10105V	SENSOR TEMP; 502AT,N PJT,-50~50,5V,-,-,RO	SA	1
8-2	DA97-05063D	3	RF141	DA61-03393B	PLATE-MULTI FRE REAR HIGH; HERMES,PP,-, W1	SA	1
9	DA90-05343M	2	RF396	DA63-05623A	COVER-LAMP FRE; HERMES,PP,NTR,DISP,LED	SA	1
10	DA90-05939B	2	RF005	DA97-05052P	ASSY-COVER EVAP FRE; HERMES10	SA	1

No.	Parent	Lvl.	Loc.	Material Code	Description & Specification	SNA	Qty.
10-1	DA97-05052P	3	RF168	DA61-05991C	PLATE-EVAP HEATER FRE; HERMES, GL-SAZCC, T0	SA	1
10-2	DA97-05052P	3	RK182	DA31-00053A	FAN-BACKWARD; -, A-TOP, ABS, -, FRE	SA	1
10-3	DA97-05052P	3	RR053	DA61-20128A	SPRING ETC-FAN; STS304, PI8.8, ID7.8, OD9.8,	SA	1
10-4	DA97-05052P	3	RY172	DA61-00417A	CASE MOTOR; A-TOP, ABS SCRAP, -, -, WHT, SBS	SA	1
10-5	DA97-05052P	3	RR334	6002-001204	SCREW-TAPPING; TH, +, -, 1, M4, L16, PASS, STS43	SA	4
10-7	DA97-05052P	3	RR066	DA63-40167A	GROMMET-COVER CHIL; SILICON, L16, WHITE	SA	1
10-8	DA97-05052P	3	RY711	DA39-00060B	WIRE HARNESS-MOTOR; -, -, -, -, F-FAN, -, -	SC	1
10-9	DA97-05052P	3	RF431	DA31-00146E	MOTOR FAN-BLDC; DREP5020LB, BLDC Motor, 0.2	SA	1
11	DA90-05340E	2	RF011	DA96-00675P	ASSY EVAP-FRE; HERMER, FIN PIPE, A1070S-H14	SA	1
11-1	DA96-00675P	3		DA47-00320L	HEATER-SHEATH-METAL FRE; HM10, INCOLOY840,	SA	1
11-2	DA96-00675P	3	RF169	DA61-05989B	PLATE-DRAIN EVAP FRE; HERMES, GL-SAZCC, T0.	SA	1
11-3	DA96-00675P	3	RR336	DA32-00029N	SENSOR TEMP; DTN-C502G6X, NEXT-PJT, 40~110	SA	1
11-4	DA96-00675P	3	RK215	DA61-00603A	FIXER-SENSOR; n-PJT, PP, -, -, -	SA	1
11-5	DA96-00676K	3	RF217	DA61-05160A	FIXER-FUSE; CULLI_09, PP, BJ-730, NTR, -	SA	1
11-6	DA96-00675P	3	RR342	DA47-00301F	THERMO FUSE-ASSY; TWIN, 120V/250V, 15A/10A,	SA	1
11-7	DA96-00676K	3	RR006	DA61-06013A	FIXER-WIRE; AW3-PJT, PP, NTR	SC	2
12	DA97-08744D	3		DA41-00519P	PBA-LED LAMP; SSEDA, R-ROOM, CEM-1, 100*20*1	SA	2

2. Fridge

Exploded View

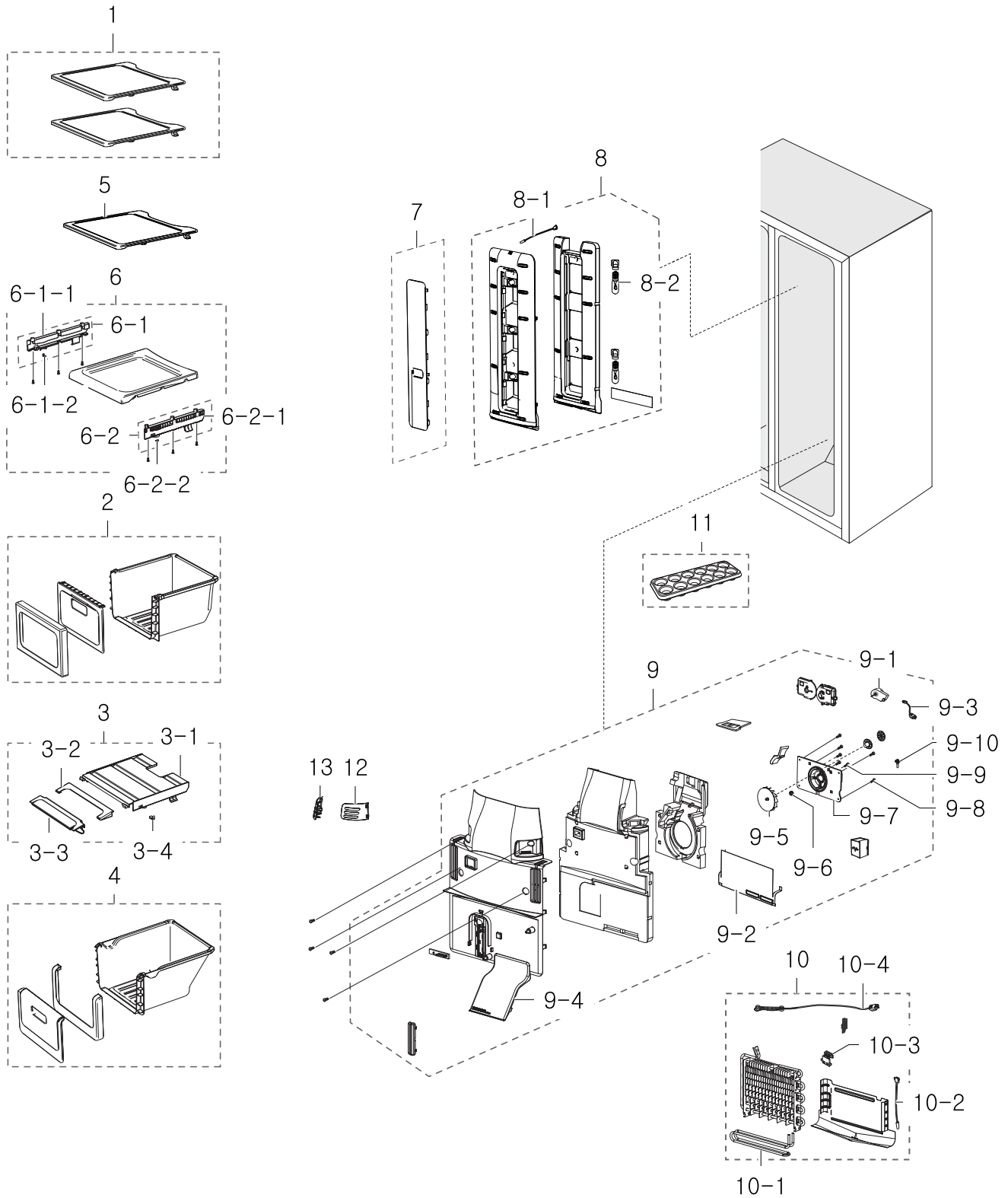

Parts List

No.	Parent	Lvl.	Loc.	Material Code	Description & Specification	SNA	Qty.
1	DA90-03679C	2	RI672	DA67-01694A	SHELF REF-TOP; HERMES-PJT,PP+GLASS,T2.0,	SA	2
2	DA90-05343M	2	RI087	DA97-05045B	ASSY-CASE VEG HIGH; HERMES,GPPS+HIPS,-,-	SA	1
3	DA90-05343M	2	RG143	DA97-05048D	ASSY-COVER SLIDE VEG; HERMES,ABS+HIPS,WRA	SA	1
3-1	DA97-05048D	3	RI009	DA63-03566A	COVER VEG-LOW; HERMES,ABS,-,-,-,-,TRP,-	SA	1
3-2	DA97-05048D	3	RI108	DA63-03567A	COVER-SLIDE VEG A; HERMES,HIPS,-,-,-,-,-	SA	1
3-3	DA97-05048D	3	RI109	DA63-03568A	COVER-SLIDE VEG B; HERMES,ABS,-,-,-,-,-,T	SA	1
3-4	DA97-05049C	3	RK243	DA63-00202C	GROMMET-RAIL; TD-PJT,NY-66,W10.7,L15,COOL	SA	2
4	DA90-05343M	2	RI001	DA97-05044B	ASSY-CASE VEG LOW; HERMES,GPPS+HIPS,-,-	SA	1
5	DA90-03679C	2	RI664	DA67-02109A	SHELF REF-MID; HERMES-PJT,PP+GLASS,-,W443	SA	1
6	DA90-03679C	2	RI039	DA97-06928A	ASSY-SHELF REF LOW; HERMES,-,-,-	SA	1
6-1	DA97-06927A	3	RR838	DA97-05233B	ASSY RAIL-BOX L; HERMES-PJT,T2.0,W17,L260	SA	1
6-1-1	DA97-05233B	4	RK458	DA61-03413B	RAIL-BOX L; HERMES-PJT,TALC PP,-,-,-,NATU	SA	1
6-1-2	DA97-05234B	4	RK243	DA63-00202C	GROMMET-RAIL; TD-PJT,NY-66,W10.7,L15,COOL	SA	1
6-2	DA97-06927A	3	RR840	DA97-05234B	ASSY RAIL-BOX R; HERMES-PJT,T2.0,W17,L260	SA	1
6-2-1	DA97-05234B	4	RK460	DA61-03412B	RAIL-BOX R; HERMES-PJT,TALC PP,-,-,-,NATU	SA	1
6-2-2	DA97-05234B	4	RK243	DA63-00202C	GROMMET-RAIL; TD-PJT,NY-66,W10.7,L15,COOL	SA	1
7	DA90-05343M	2	RG028	DA63-05298A	COVER-LAMP REF; HM10,LED,PP,NTR	SA	1
8	DA90-05939B	2	RI019	DA97-08257F	ASSY COVER-MULTI REF; HM10,IN_DOOR,LED,PP	SA	1
8-1	DA96-00675P	3	RR336	DA32-00029N	SENSOR TEMP; DTN-C502G6X,NEXT-PJT,40~110	SA	1
8-2	DA97-08744D	3		DA41-00519P	PBA-LED LAMP; SSEDA,R-ROOM,CEM-1,100*20*1	SA	2
9	DA90-05939B	2	RI008	DA97-08285N	ASSY COVER-EVAP REF; HM10,BASIC,LED,230V	SA	1
9-1	DA97-05052P	3	RF431	DA31-00146E	MOTOR FAN-BLDC; DREP5020LB,BLDC Motor,0.2	SA	1
9-2	DA97-08285N	3	RI529	DA61-05993B	PLATE-EVAP HEATER REF; HERMES,AL,T0.3	SA	1

Exploded Views and Parts List

No.	Parent	Lvl.	Loc.	Material Code	Description & Specification	SNA	Qty.
9-3	DA97-05052P	3	RY711	DA39-00060B	WIRE HARNESS-MOTOR; -, -, -, -, -, -, F-FAN, -, -	SC	1
9-4	DA97-08285N	3	RI616	DA63-03594A	COVER EVAP-REF; HERMES, PP, -, -, -, -, -, COOL	SNA	1
9-5	DA97-08285N	3	RK183	DA31-00123A	FAN-BACKWARD; -, USP 05, ABS(HP-0760), -, 2.0	SC	1
9-6	DA97-05052P	3	RR053	DA61-20128A	SPRING ETC-FAN; STS304, PI8.8, ID7.8, OD9.8,	SA	1
9-7	DA97-08285N	3	RF121	DA61-05286B	CASE-MOTOR REF; HERMES 09, HIPS, NTR	SA	1
9-8	DA97-05052P	3	RR334	6002-001204	SCREW-TAPPING; TH, +, -, 1, M4, L16, PASS, STS43	SA	4
9-9	DA97-05052P	3	RR012	6002-000471	SCREW-TAPPING; TH, +, -, 1, M4, L12, PASS, STS30	SA	3
9-10	DA97-05052P	3	RR066	DA63-40167A	GROMMET-COVER CHIL; SILICON, L16, WHITE	SA	1
10	DA90-05340E	2	RI016	DA96-00676K	ASSY EVAP-REF; HERMES, FIN PIPE, A1070S-H14	SA	1
10-1	DA96-00676K	3		DA47-00321L	HEATER-SHEATH-METAL; HM10-PJT, NCOLOY840, 1	SA	1
10-2	DA96-00676K	3	RK704	DA32-00029R	SENSOR TEMP; DTN-C502G6X, SEDA-PJT, 40~110	SA	1
10-3	DA96-00675P	3	RK215	DA61-00603A	FIXER-SENSOR; n-PJT, PP, -, -, -	SA	1
10-4	DA96-00676K	3	RR341	DA47-00301B	THERMO FUSE-ASSY; HERMES, 120V/250V, 15A/10	SA	1
11	DA90-05343M	2	RE355	DA67-40322A	TRAY-EGG; SR-51.55.59, GPPS, -, -, -, -, -	SA	1
12	DA90-05343M	2	RG131	DA63-03606A	COVER-DEODORIZER R; HERMES, PP, -, -, -, -, -, C	SA	1
13	DA90-05343M	2	RG130	DA63-03605A	COVER-DEODORIZER L; HERMES, PP, -, -, -, -, -, C	SA	1

3. Cabinet/Unit

Exploded View

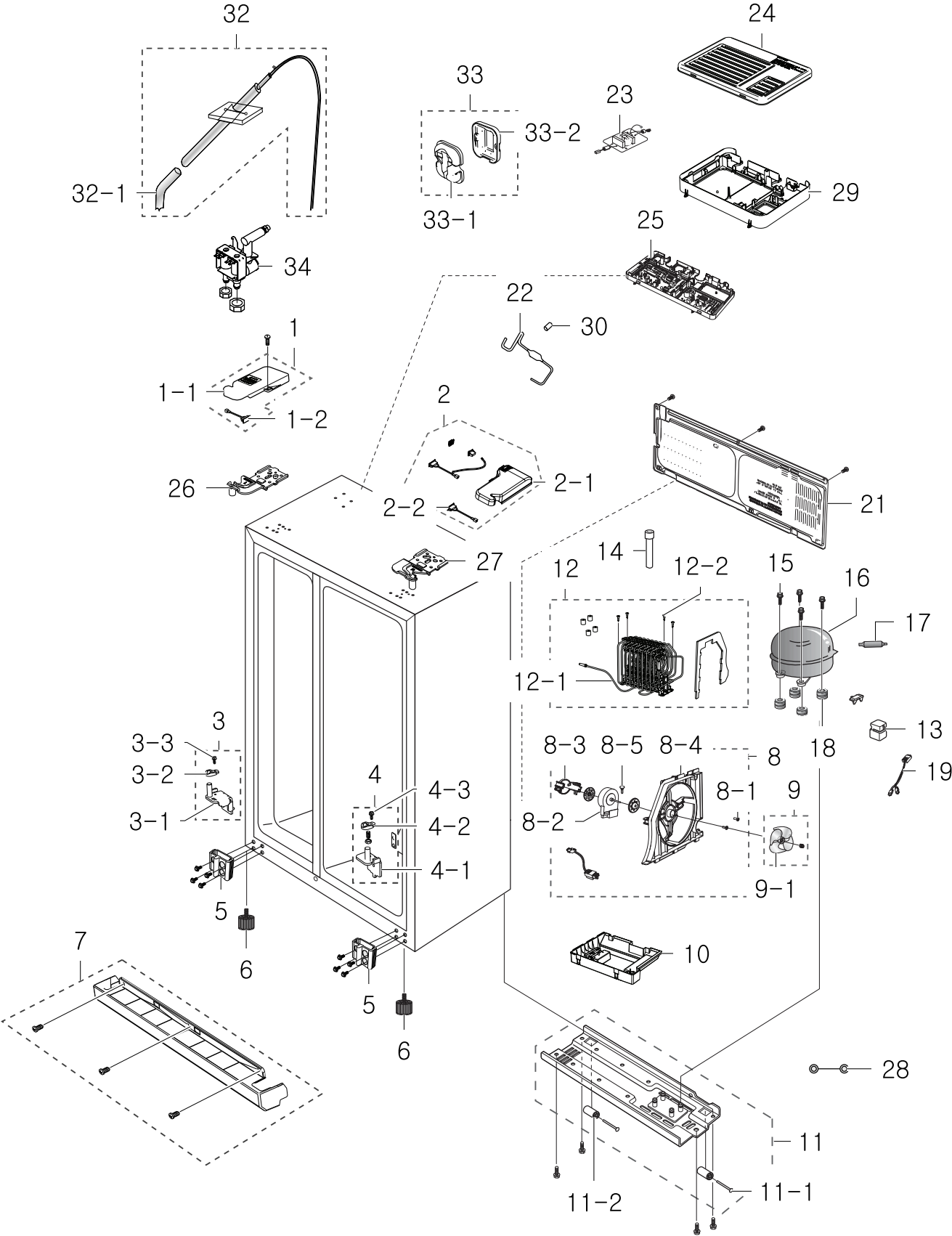

Parts List

No.	Parent	Lvl.	Loc.	Material Code	Description & Specification	SNA	Qty.
1	DA90-05375E	2	RO044	DA97-05663A	ASSY COVER HINGE-TOP L; HERMES,-,-,-,-,-,	SA	1
1-1	DA97-05663A	3	RO310	DA63-03896A	COVER-HINGE TOP L; HEMRES,ABS,T2.5,-,-,-,-,	SA	1
1-2	DA97-05663A	3	RK819	DA34-00043A	SWITCH REED-ASS'Y; 200VDC,1.5,-	SA	1
2	DA90-05375E	2	RO046	DA97-07895C	ASSY COVER-HINGE TOP R-TK; HM09,ASSY,I-BL	SA	1
2-1	DA97-07895C	3	RO455	DA63-05154C	COVER-HINGE TOP R TK; HM09,ABS,I-BLACK(SC	SA	1
2-2	DA97-07895C	3	RY001	DA34-00043F	SWITCH REED-ASSY; 200VDC,1.5A,HERMES,GGH	SA	1
3	DA90-05375E	2	RO037	DA97-04355B	ASSY HINGE LOW-,L; A-TOP 06,SHP1,T4.5,-,-	SA	1
3-1	DA97-04355B	3	RO553	DA61-02965B	HINGE-LOW, L; SHP1+SM45C,SAPPHIRE,T4.5,-,	SA	1
3-2	DA97-04354C	3	RR981	DA66-00401A	CAM-RISER; SAPPHIRE-PJT,NY-66,BLACK,2110R	SA	1
3-3	DA97-04354C	3	RR335	6003-001435	SCREW-TAPTYPE; HWH,+,-,S,M5,L12.7,ZPC(WHT	SA	1
4	DA90-05375E	2	RO038	DA97-04354C	ASSY HINGE-LOW R; HM09,SHP1+SM45C,T4.5,ZP	SA	1
4-1	DA97-04354C	3	RO436	DA61-02966A	HINGE-LOW, R; SAPPHIRE-PJT,SHP1+SM45C,T4.	SA	1
4-2	DA97-04354C	3	RR981	DA66-00401A	CAM-RISER; SAPPHIRE-PJT,NY-66,BLACK,2110R	SA	1
4-3	DA97-04354C	3	RR335	6003-001435	SCREW-TAPTYPE; HWH,+,-,S,M5,L12.7,ZPC(WHT	SA	1
5	DA90-05327H	2	RO500	DA61-03298C	BRACKET HINGE-LOW; A-TOP 50mm,AL(6063),T2	SC	2
6	DA97-08325K	3	RO100	DA61-00805F	FOOT-FRONT; REF-ALL,PP+MSWR10,BLACK,PP_S	SA	2
7	DA90-05375E	2	RO287	DA63-05031D	COVER-LEG FRONT; HM09,PP,I-BLACK,55MM	SA	1
8	DA90-05340E	2	RO132	DA97-03870B	ASSY SUPPORT-CIRCUIT MOTOR; ET/ATOP_VE,-,	SA	1
8-1	DA97-03870B	3	RR005	6003-000003	SCREW-TAPTYPE; BH,+,-,B,M4,L10,ZPC(BLK),S	SA	2
8-2	DA97-03870B	3	RR088	DA31-00146B	MOTOR BLDC; DRCP5030LA,1560,-,DC12V,230mA	SC	1
8-3	DA97-03870B	3	RH039	DA61-02355B	BRACKET-CIRCUIT MOTOR; ABS,NEXT,-,-,-,NTR	SA	1
8-4	DA97-03870B	3	RF412	DA61-02788A	SUPPORT-CIRCUIT MOTOR; ET/A-TOP_VE,ABS,T2	SA	1

No.	Parent	Lvl.	Loc.	Material Code	Description & Specification	SNA	Qty.
8-5	DA97-05052P	3	RR066	DA63-40167A	GROMMET-COVER CHIL; SILICON,L16,WHITE	SA	1
9	DA90-05340E	2	RK180	DA31-00010F	FAN-ASSY; SBS,ABS+GLASSFIBER, 150,3-Win	SA	1
9-1	DA31-00010F	3	RR029	DA31-00015C	FAN-TURBO; -,ET-PJT,ABS+GLASS FIBE,-,GR-4	SA	1
10	DA97-03869G	3	RH885	DA63-03069B	TRAY DRAIN-WATER; HERMES-PJT,PP SCRAP,-,W	SA	1
11	DA90-05340E	2	RO002	DA97-03971E	ASSY CHASSIS-COMP; HERMES,-,-,W255.5,L895	SA	1
11-1	DA97-03971E	3	RH012	DA61-01920A	CASTER-RIVET; (ZPC2),MSWR10,OD8.0,L58	SA	2
11-2	DA97-03971E	3	RR242	DA61-04703A	CASTER-REAR; AW-PJT,PP,-,35,NTR,35,PP+TPE	SA	2
12	DA90-05340E	2	RH003	DA97-03869G	ASSY TRAY-DRAIN WATER; HERMES-PJT,W242.3,	SA	1
12-1	DA97-03869G	3	RW002	DA97-03962E	ASSY PIPE-SPIRAL COND; HERMES-PJT,VE	SA	1
12-2	DA97-03869G	3	RR022	6009-001252	SCREW-SPECIAL; PH,+,-,M4.0,L20(12),ZPC(WH	SA	4
13	DA97-02895V	3	RS734	2301-001848	C-FILM,LEAD; 5000nF,-5/10%,450V,Bulk,50x2	SA	1
14	DA90-05340E	2	RR856	DA97-04045A	ASSY TUBE-DRAIN; ET-PJT,SOFT-PVC	SA	2
15	DA90-05340E	2	RR965	DA60-20008A	BOLT-HEX; S25C,M6,L42.6,WHITE,ZPC	SA	4
16	DA90-05340E	2	RH002	MK4A5QR1U/E10	COMPRESSOR,RSCR,15.32CC,220-240VSTATIC; COMPRESSOR,RSCR,15.32CC,220-240VSTATIC	SA	1
17	DA90-05340E	2	RC050	DA62-02614P	DRYER-SINGLE; HAEMIL_10,C1220T,OD18.7,L11	SA	1
18	DA90-05340E	2	RH732	DA63-02017A	GROMMET COMP; QUEEN,EPDM,BLACK	SA	4
19	DA90-05340E	2	RH070	DA97-02895V	ASSY-COMP SUB; HERMES09,MK4A5Q	SA	1
21	DA90-05375E	2	RH001	DA97-05202H	ASSY COVER-COMP; HERMES,SBHG1,T0.3,SEAL C	SA	1
22	DA90-05340E	2	RT094	DA97-06085B	ASSY PIPE CONNECT-SUCTION; HM10	SA	1
23	DA90-05340E	2	RH083	DA27-00019H	COIL FILTER-EMI; AW3-PJT,20mH,82*60,-25 ~	SA	1
24	DA90-05375E	2	RO286	DA63-05523A	COVER-PCB PANEL; HM10,GI-SGCC,T0.35	SA	1
25	RS21HFLMR1/XFA	1	RY475	DA41-00726E	ASSY PCB MAIN; HM09-PJT LED, TOP OF REF,FR	SA	1
26	DA97-02278D	3	RO129	DA61-01876D	HINGE-UPP L; A-TOP,USP,10.5mm GASKET,50mm	SA	1

Exploded Views and Parts List

No.	Parent	Lvl.	Loc.	Material Code	Description & Specification	SNA	Qty.
27	DA97-02279D	3	RO128	DA61-01877D	HINGE-UPP R; A-TOP,USP,10.5mm GASKET,50mm	SA	1
28	DA90-05340E	2	RK934	DA39-20389L	WIRE HARNESS-EARTH; TMF/LMF,AWG #18	SC	1
29	DA90-05375E	2	RO191	DA61-04706A	CASE-PBA MAIN; HERMES,N-PP,-,-,NTR,NONF	SA	1
30	DA97-08565C	3		DA63-02667A	GROMMET-SUCTION PIPE; A-TOP,NBR,BLACK,-,-	SNA	1
32	DA90-05747D	2	RF290	DA97-05070A	ASSY-PIPE WATER FRE; HERMES,230V/10W,-,-	SC	1
32-1	DA97-05070A	3	RF059	DA63-03629A	GROMMET-WATER PIPE FILL IN; HERMES,SILICO	SA	1
33	DA90-05747D	2	RO347	DA97-00979C	ASSY COVER-PIPE WATER; HERMES-PJT,PP RECY	SA	1
33-1	DA97-00979C	3	RO115	DA63-00476B	COVER-PIPE WATER; HERMES-PJT,PP SCRAP,-,-	SA	1
33-2	DA97-00979C	3		DA72-00228C	SEAL-WATER PIPE; ET-PJT,FOAM-PE,-,T10,L80	SNA	1
34	DA90-05747D	2	RO089	DA97-02682A	ASSY VALVE WATER; EPEL,-,-,-,-	SA	1

4. Freezer Door

Exploded View

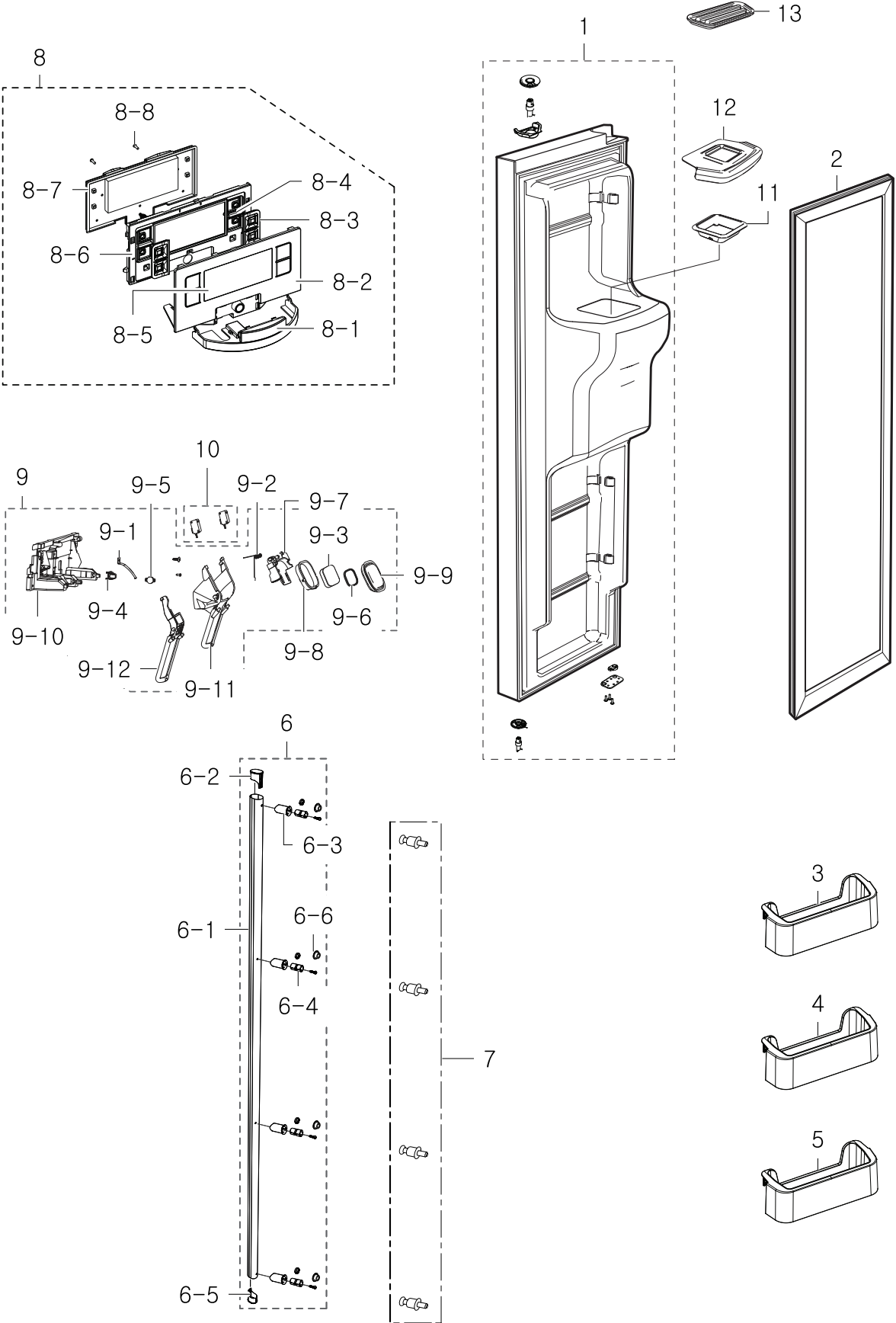

Parts List

No.	Parent	Lvl.	Loc.	Material Code	Description & Specification	SNA	Qty.
1	DA90-05485A	2	RD001	DA91-02912A	ASSY DOOR FOAM FRE; HM09,E/BLACK,N,BWT,R(SA	1
2	DA90-05485A	2	RU513	DA97-04567N	ASSY-GASKET DOOR FRE; HM10 SEPM,BLACK	SA	1
3	DA97-04967C	3	RD350	DA63-03541C	GUARD-FRE TOP; HERMES PJT,ABS,T2.5,-,-,CO	SA	1
4	DA97-04968B	3	RK252	DA63-03554B	GUARD FRE-LOW; HERMES PJT,ABS,T2.5,-,-,CO	SA	1
5	DA97-04968C	3	RK253	DA63-03554C	GUARD FRE-LOW; HERMES PJT,ABS,T2.5,-,-,CO	SA	1
6	DA90-05485A	2	RO017	DA97-05733E	ASSY-HANDLE BAR; HERMES,-,I-BLACK,-	SA	1
6-1	DA97-05733E	3	RO391	DA64-02617B	HANDLE BAR; HERMES,AL,T1.0,-,L1628.5,-,SC	SA	1
6-2	DA97-05733E	3	RK020	DA67-02024B	CAP-HANDLE SIDE; CORE,ABS,-,-,-,NTR,SILVE	SA	1
6-3	DA97-05733E	3	RO527	DA67-01810B	CAP-SUPT HANDLE; HERMES,ABS,-,-,-,SC-0047	SA	4
6-4	DA97-05733E	3	RO587	DA61-03636A	STOPPER-HANDLE; CULLINAN,SK5,-,-,-,-,-	SA	4
6-5	DA97-05733E	3	RK021	DA67-02024D	CAP-HANDLE SIDE; CORE,ABS,-,-,-,SNOW-WHIT	SA	1
6-6	DA97-05733E	3	RJ720	DA63-03841A	GROMMET-HANDLE; NEXT T/K,SILICON,-,-,-,-,	SA	4
7	DA90-05485A	2	RO171	DA61-03634B	BRACKET-HANDLE; CULLINAN,SWCH10A,-,-,L43.	SA	4
8	DA90-05485A	2	RD240	DA97-07769N	ASSY COVER DISP-FRE TK; HM09-F,D,EUROPE(V	SA	1
8-1	DA97-07769N	3	RD243	DA64-02982B	BUTTON-DISPENSER; HM09,ABS,TITAN GRAY(SC-	SA	1
8-2	DA97-07769N	3	RD029	DA63-05056E	COVER-CONTROL DISP TK; HM09,ABS,EUROPE,EM	SA	1
8-3	DA97-07769N	3	RD236	DA63-05059A	GROMMET-BUTTON; HM09,SILICON,BLACK	SA	2
8-4	DA97-07769N	3	RD286	DA64-02983A	DECORATION-BUTTON CONTROL; HM09,ABS,NTR,P	SA	2
8-5	DA97-07769N	3	RD052	DA63-05063D	COVER-CONTROL WINDOW FRE; HM09,ACRYL,BLAC	SA	1
8-6	DA97-07769N	3	RD244	DA63-05055C	COVER DISPENSER-TK; HM09,ABS,EMPIRE BLACK	SA	1
8-7	DA97-07769N	3	RI261	DA62-01133T	SEAL CUTT-FOAM LEX; SKR2F18/2F20,FOAM-LEX	SNA	0
8-8	DA97-07769N	3	RR004	6003-000333	SCREW-TAPTYPE; RH,+,-,2S,M3,L10,ZPC(WHT),	SA	5

No.	Parent	Lvl.	Loc.	Material Code	Description & Specification	SNA	Qty.
9	DA90-05485A	2	RD463	DA97-07774A	ASSY COVER-PCB PANEL REAR; HM09,ASSY,SAN(SA	1
9-1	DA97-07774A	3	RD446	DA61-01616A	SPRING ETC-LEVER DISP WATER; AD,STS304,-,	SA	1
9-2	DA97-07774A	3	RD050	DA61-01651A	SPRING ETC-COVER ICE ROUTE; AD,STS304,1.0	SA	1
9-3	DA97-07774A	3	RK678	DA62-00058E	SEAL-COVER ICE,ROUTE; AD,FOAM-LEX,WHITE,T	SA	1
9-4	DA97-07774A	3	RD448	DA61-01868B	BRACKET-OIL DAMPER; ABS,AD,-,-,-,NTR,-	SA	1
9-5	DA97-07774A	3	RO353	DA61-01869A	OIL DAMPER; AD,POM,-,120g/Cm,-,OD15,-,-	SA	1
9-6	DA97-07774A	3	RK679	DA62-00058F	SEAL-COVER ICE,ROUTE; AD,FOAM-LEX,WHITE,T	SA	1
9-7	DA97-07774A	3	RD359	DA63-01970A	COVER-ICE ROUTE A; AD,ABS,T2.5,-,-,-,-,BL	SA	1
9-8	DA97-07774A	3	RD461	DA63-01971B	COVER-ICE ROUTE B; AD,ABS,-,-,-,-,NATUR	SA	1
9-9	DA97-07774A	3	RD051	DA63-01972A	GASKET-COVER ICE ROUTE; AD,SILICON,T1.5,-	SA	1
9-10	DA97-07774A	3	RO464	DA63-03259C	COVER PCB-PANEL REAR; A-TOP 06,ABS(HG-076	SA	1
9-11	DA97-07774A	3	RD283	DA66-00684A	LEVER-DISPENSER ICE; HM09,SAN,NTR	SA	1
9-12	DA97-07774A	3	RD284	DA66-00685A	LEVER-DISPENSER WATER; HM09,SAN,NTR	SA	1
10	DA90-05485A	2	RD460	DA34-00011B	SWITCH MICRO; -,-,-,-,250V,-,15A,-,-,-,-,	SA	2
11	DA90-05485A	2	RD266	DA67-01667A	CAP-CHUTE ICE; HERMES,ABS,T1.8,-,-,SC-027	SA	1
12	DA90-04364F	2	RD108	DA63-03729C	GUARD-FRE SUB; HERMES,PP,-,-,-,COOL-WHITE	SA	1
13	DA90-05485A	2	RO489	DA63-03580U	TRAY DISPENSER; HERMES,ABS,T2.5,DISP,SC-0	SA	1

5. Fridge Door

Exploded View

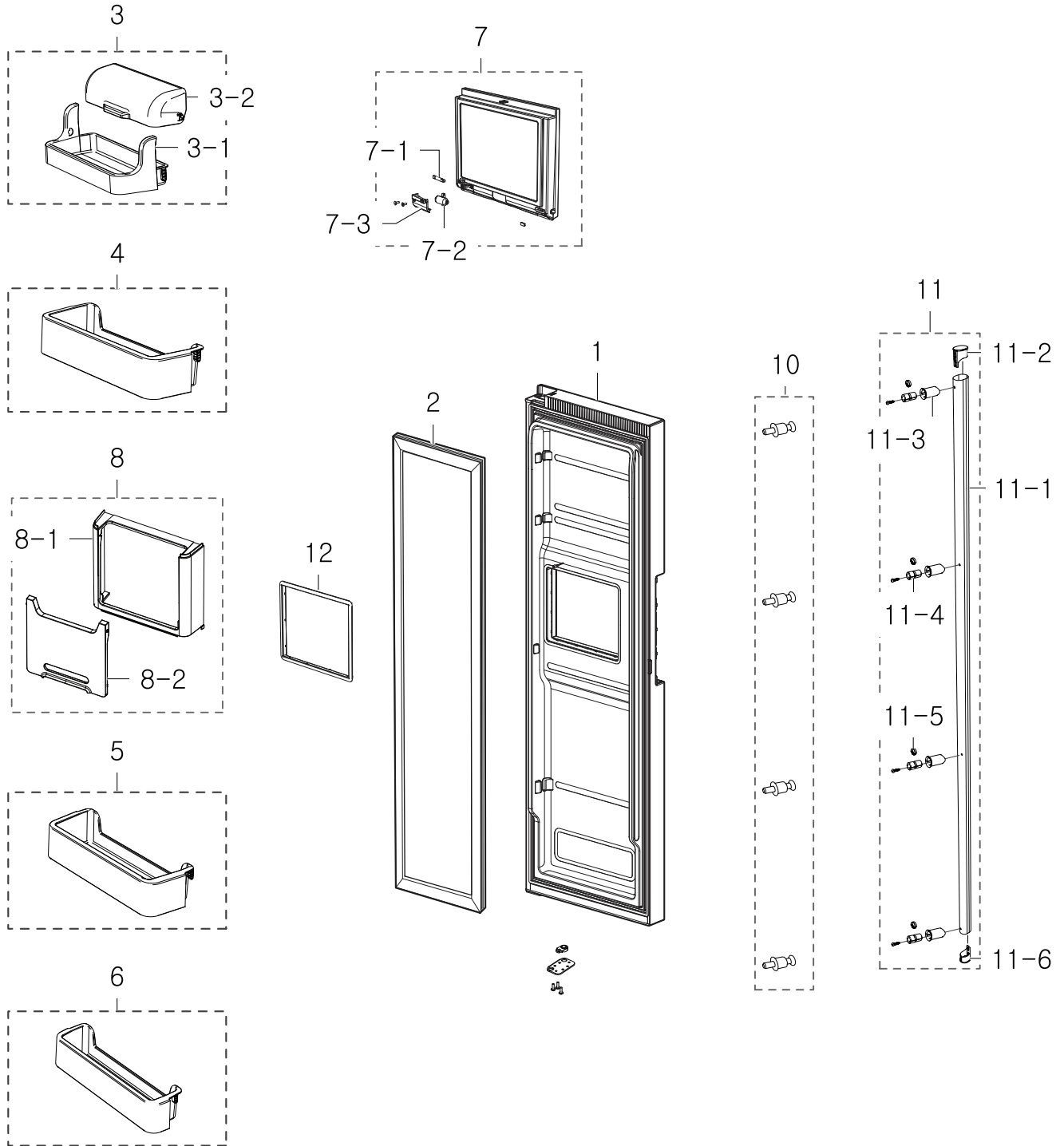

Parts List

No.	Parent	Lvl.	Loc.	Material Code	Description & Specification	SNA	Qty.
1	DA90-05338C	2	RE001	DA91-02630Q	ASSY DOOR-FOAM REF; HM10,HB,BLACK GLASS,B	SA	1
2	DA90-05338C	2	RR238	DA97-04567P	ASSY-GASKET DOOR REF; HM10 SEPM,BLACK	SA	1
3	DA90-04364F	2	RE028	DA97-07110A	ASSY GUARD-DAIRY; HERMES PJT,-,-,-,-,55	SA	1
3-1	DA97-07110A	3	RE390	DA63-04705A	GUARD-DAIRY; HERMES PJT,PP,T1.8,-,-,COOL	SA	1
3-2	DA97-07110A	3	RE386	DA63-03534A	COVER-GUARD DAIRY; HERMES PJT,GPPS/HF2660	SA	1
4	DA90-04364F	2	RE362	DA97-04964B	ASSY GUARD-REF TOP; HERMES PJT,-,-,-,-,-	SA	1
5	DA90-04364F	2	RI140	DA97-08733A	ASSY GUARD-REF MID; HM10,EUP	SA	1
6	DA90-04364F	2	RI161	DA97-04966B	ASSY GUARD-REF LOW; HERMES PJT,-,-,-,-,-	SA	1
7	DA90-05338C	2	RE391	DA97-10996A	ASSY-HOME BAR FOAM; HERMES09,T/K,EMPIRE B	SA	1
7-1	DA97-10996A	3	RO232	DA66-00205C	SHAFT-DAMPER HOMEBAR; CULLINAN,STS304,45.	SA	1
7-2	DA97-10996A	3	RQ032	DA97-03956D	ASSY DAMPER-HOMEBAR; HERMES,-,EXPORT,-,10	SA	1
7-3	DA97-10996A	3	RE172	DA67-01842A	CAP-HOME BAR LOW; HERME-PJT,ABS,T2.5,-,-,	SA	1
8	DA90-04364F	2	RE292	DA97-05851D	ASSY-COVER DOOR RECESS; HERMES,ASSY,55mm	SA	1
8-1	DA97-05851D	3	RE285	DA61-03883B	CASE-DOOR RECESS; HERMES,HIPS,T2.5,415.9,	SA	1
8-2	DA97-05851D	3	RE335	DA63-03937A	COVER-DOOR RECESS; HERMES,GPPS,T3.0,329.2	SA	1
10	DA90-05485A	2	RO171	DA61-03634B	BRACKET-HANDLE; CULLINAN,SWCH10A,-,-,L43.	SA	4
11	DA90-05485A	2	RO017	DA97-05733E	ASSY-HANDLE BAR; HERMES,-,I-BLACK,-	SA	1
11-1	DA97-05733E	3	RO391	DA64-02617B	HANDLE BAR; HERMES,AL,T1.0,-,L1628.5,-,SC	SA	1
11-2	DA97-05733E	3	RK020	DA67-02024B	CAP-HANDLE SIDE; CORE,ABS,-,-,-,NTR,SILVE	SA	1
11-3	DA97-05733E	3	RO527	DA67-01810B	CAP-SUPT HANDLE; HERMES,ABS,-,-,-,SC-0047	SA	4
11-4	DA97-05733E	3	RO485	DA61-03635A	SUPPORT-HANDLE; Cullinan,NY66,-,-,-,-	SA	4
11-5	DA97-05733E	3	RO587	DA61-03636A	STOPPER-HANDLE; CULLINAN,SK5,-,-,-,-,-	SA	4

Exploded Views and Parts List

No.	Parent	Lvl.	Loc.	Material Code	Description & Specification	SNA	Qty.
11-6	DA97-05733E	3	RK021	DA67-02024D	CAP-HANDLE SIDE; CORE,ABS,-,-,-,SNOW-WHIT	SA	1
12	DA90-05338C	2	RE097	DA64-03215A	TRIM-CASE BRACKET OUT; HM10,ABS,COOL WHIT	SA	1