

1. AC140HCADKH/EU

Exploded View

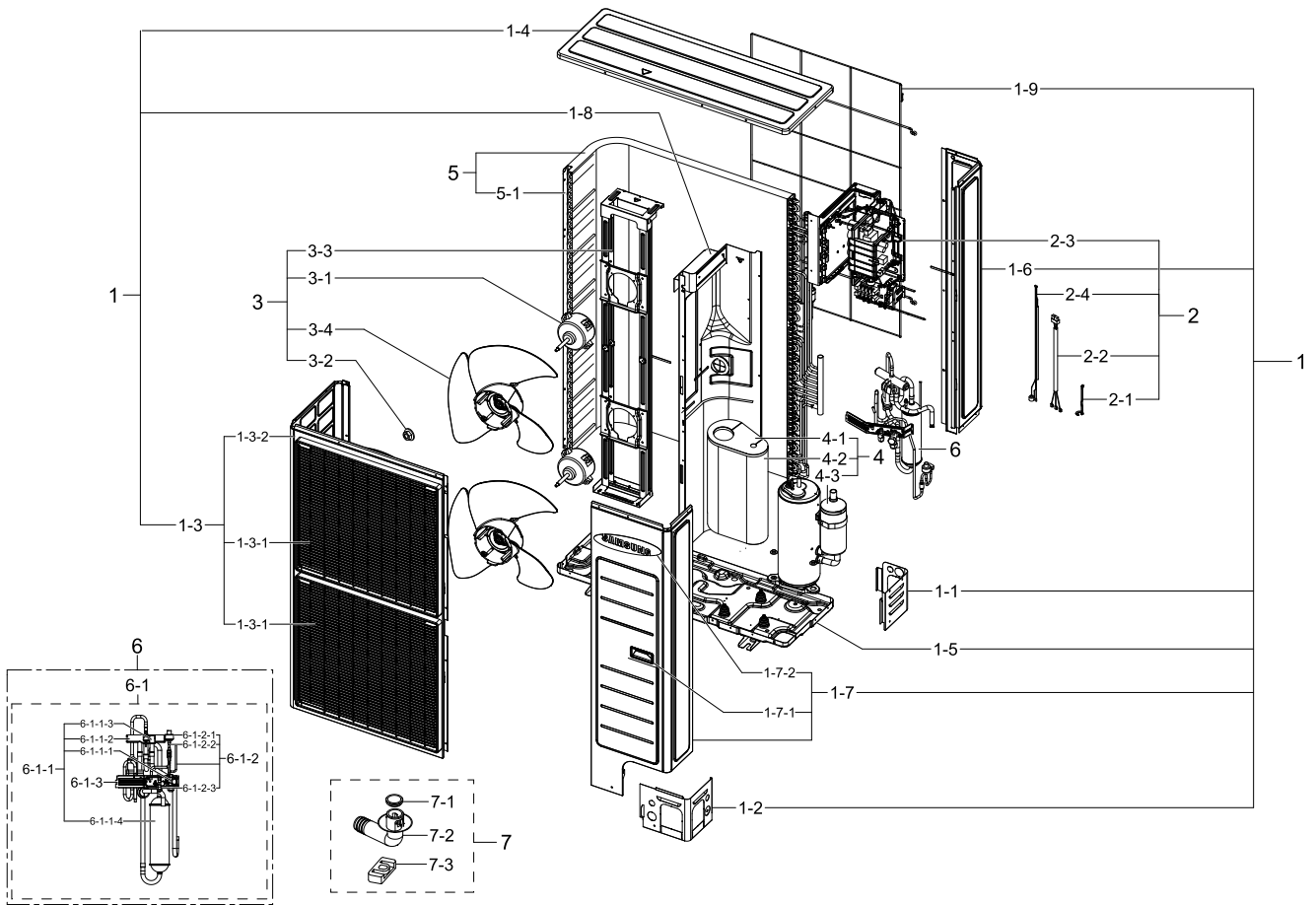

Parts List

No.	Lvl.	Loc.	Material Code	Description & Specification	SNA	Qty.
1	1		DB90-05872C	ASSY CABI OUT PARTS; AC140HCADKH/EU	SNA	1
1-1	2		DB64-02525C	CABINET-INSTALL BACK; RC160MHXEA,EGI-SECC	SA	1
1-2	2		DB64-02526C	CABINET-INSTALL FRONT; RC100PHXEA,EGI-SEC	SA	1
1-3	2	A2620	DB90-05878B	ASSY CABI FRONT-LF; RC100PHXEA,ManU,EARTH	SA	1
1-3-1	3		DB63-02696B	GUARD-FAN; RC100PHXEA,PP,EARTH BROWN	SA	2
1-3-2	3		DB64-02522B	CABINET FRONT-LF; RC100PHXEA,EGI-SECC,T0.	SNA	1
1-4	2	A0212	DB90-05902E	ASSY CABINET-TOP; RC090MHXEA,EHS MONO	SA	1
1-5	2	A0092	DB90-05873H	ASSY BASE OUT; AC100HCADKH/EU	SNA	1
1-6	2	A2609	DB90-05876D	ASSY CABI BACK-RH; RC100PHXEA,EARTH BROWN	SA	1

Exploded Views and Parts List

No.	Lvl.	Loc.	Material Code	Description & Specification	SNA	Qty.
1-7	2	A0173	DB90-05877C	ASSY CABI FRONT RH; RC100PHXEA,MANU	SA	1
1-7-1	3		DB64-02613B	HANDLE; RC140PHXEA,PP,T2.5,EARTH BROWN,HE	SNA	1
1-7-2	3	L0084	DB98-08770K	ASSY-LOGO SAMSUNG; PANTONE286C,250, PVC T	SA	1
1-8	2	A1748	DB94-02697C	ASSY PARTITION; RC100PHXEA,MANU	SNA	1
1-9	3		DB63-02706D	GUARD COND; RC100ZHXE,MSWR-SWRM,741,1064	SA	1
2	1		DB93-14997A	ASSY CONTROL OUT PARTS; HP,Inv,14.0kW,AC1	SNA	1
2-1	2	S0242	DB81-00635A	SPRING ETC-SENSOR; DVM-SYSTEM,STS304,R2.5	SA	2
2-2	2	A0630	DB93-08235G	ASSY CONNECTOR WIRE-COMP; 3,3343,12,RED,H	SA	1
2-3	2	A3096	DB93-11292U	ASSY CONTROL OUT; HP,Inv,14.0kW,AC140HCAD	SNA	1
2-4	2		DB95-04871B	ASSY THERMISTOR OUT-SUB OUT; MAIN PBA SEN	SA	1
3	1		DB94-04798A	ASSY FAN OUT PARTS; AC140HCADKH/EU	SNA	1
3-1	2	M0039	DB31-00579B	MOTOR FAN; 125W,DC310V	SA	2
3-2	2		DB60-00405A	FASTENER-WASHER; RC100ZHXE,SWRCH10A,M8,2	SA	2
3-3	2	A2803	DB90-05875D	ASSY BRACKET MOTOR; AC140HCADKH/EU	SA	1
3-4	2		DB94-03278B	ASSY FAN PROPELLER; MAN-U,480 PI, NATURAL	SA	2
4	1		DB95-04553A	ASSY COMP PARTS; RC100PHXEA,Global 4W-CST	SNA	1
4-1	2		DB63-03166A	CLOTH-COMP TOP; FELT+EVAR,T11.5,GRAY	SA	1
4-2	2		DB63-03167A	CLOTH-COMP SOUND; FELT+EVAR,T11.5,GRAY	SA	1
4-3	2		UG5T450FUEJXSG	RCP,55,F,R410A; RCP,55,F,R410A		1
5	1		DB96-20031A	ASSY COND PARTS; AC140HCADKH/EU	SNA	1
5-1	2		DB96-20036A	ASSY COND BENDING; AC140HCADKH/EU,UB2	SA	1
6	1		DB96-20026A	ASSY TUBE OUT PARTS; AC140HCADKH/EU	SNA	1
6-1	2	A0081	DB96-19979A	ASSY TUBE-VALVE; AC140HCADKH/EU	SA	1
6-1-1	3		DB96-19972A	ASSY TUBE 4WAY; AC140HCADKH/EU	SA	1
6-1-1-1	4	Z0161	DB62-09658A	VALVE SERVICE-SPINDLE; .,5/8",R410A, FLAR	SA	1
6-1-1-2	4	V0010	DB62-02834A	VALVE 4WAY; .,-,Common,5	SA	1
6-1-1-3	4	S0247	DB33-00002J	SOLENOID-COIL ASSY; 220V,2,YEL	SA	1
6-1-1-4	4	A0316	DB96-14716A	ASSY-ACCUMULATOR; RC100PHXEA,1600CC	SA	1
6-1-2	3		DB96-19975A	ASSY TUBE EEV; AC140HCADKH/EU	SA	1
6-1-2-1	4		DB62-11206D	VALVE COIL EXPAN; DC12V,COIL,2000,18.95,M	SA	1

No.	Lvl.	Loc.	Material Code	Description & Specification	SNA	Qty.
6-1-2-2	4	V0001	DB62-04421A	VALVE EXPAN; SUS,2.4,500	SA	1
6-1-2-3	4	Z0163	DB62-09654A	VALVE SERVICE-SPINDLE; FLARE,R410A,9.52	SA	1
6-1-3	3		DB90-05874C	ASSY BRACKET-VALVE; RC100DHXEA,T1.2, UB	SA	1
7	2		DB98-34943A	ASSY PACKING ACCESSORY; AC100HCADKH/EU,GI	SNA	1
7-1	3	Z0165	DB63-10355C	CAP-DRAIN; CR,T2,BLACK,ASH-1814ER	SA	5
7-2	3	D0116	DB67-00806A	DRAIN-PLUG OUT; UH140GAV,PE,1,WHITE,INVER	SA	2
7-3	3	Z0166	DB73-20134A	RUBBER-LEG; V2-MD,NR,55	SA	4

2. ASSY CONTROL OUT

Exploded View

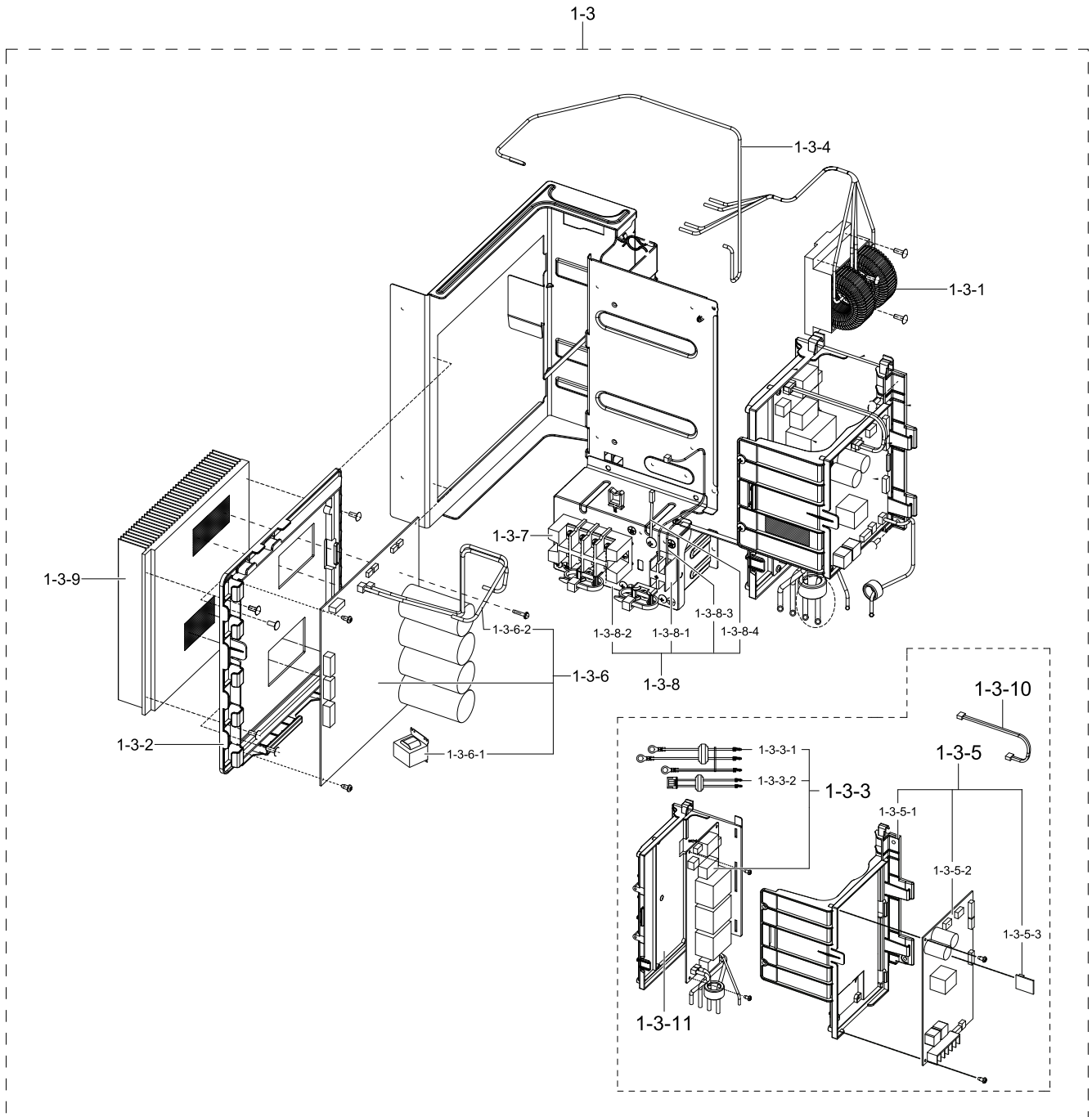

Parts List

No.	Lvl.	Loc.	Material Code	Description & Specification	SNA	Qty.
1-3	2	A3096	DB93-11292U	ASSY CONTROL OUT; HP,Inv,14.0kW,AC140HCAD	SNA	1
1-3-1	3	Z0157	DB59-00016A	AC REACTOR; RC100PHXEA,500uH,15A	SA	1
1-3-2	3		DB61-04504B	CASE-INV; RC100ZHXEAA,ABS,235.5,247.3,NTR,	SA	1
1-3-3	3	A1781	DB93-11110A	ASSY PCB SUB-EMI; GLOBAL-4WAY OUTDOOR,Inv	SA	1
1-3-3-1	4	A0664	DB93-10872A	ASSY CONNECTOR WIRE-POWER; RC160RHXH1	SA	1
1-3-3-2	4	A0664	DB93-10870B	ASSY CONNECTOR WIRE-POWER; RC100PHXEA	SA	1
1-3-4	3	Z0158	DB93-10807A	ASSY CONNECTOR WIRE-MAIN TO INVERTER COM; ASSY CONNECTOR WIRE-MAIN TO INVERTER COM	SA	1
1-3-5	3		DB90-07578B	ASSY CASE PCB; AC140HCADKH/EU	SNA	1
1-3-5-1	4		DB61-05743A	CASE-PCB; AM053FXMDCH/AA,HIPS,T2.0,141.9,	SA	1
1-3-5-2	4	A2748	DB92-03237A	ASSY PCB MAIN; MAIN-OUT,CAC_OUT,192*120,2	SA	1
1-3-5-3	4		DB93-12483A	ASSY PCB SUB-EEPROM; DVM PLUS4UP,DVM WATE	SA	1
1-3-6	3	A2573	DB93-11112D	ASSY PCB MAIN-INVERTER; RC100DHXEA, RC100	SA	1
1-3-6-1	5	T0083	DB26-00123A	TRANS SWITCHING; EE2218,RC100PHXEA,GLOBAL	SA	1
1-3-6-2	5	A0664	DB93-10870A	ASSY CONNECTOR WIRE-POWER; RC160RHXH1	SA	1
1-3-7	3		DB65-00296A	TERMINAL BLOCK-POWER 4P; RC140DHXEA,PC/PB	SA	1
1-3-8	3	A3096	DB93-10966L	ASSY CONTROL OUT; HP,Inv,14.0kW,AC140HCAD	SNA	1
1-3-8-1	4	T0179	DB65-00274A	TERMINAL BLOCK; TERMINAL BLOCK,2-TAB_2-SC	SA	1
1-3-8-2	4		DB90-05889A	ASSY CASE CONTROL OUT; RC100PHXEA,ManU	SA	1
1-3-8-3	4	A2934	DB93-10808J	ASSY CONNECTOR WIRE-COMM; ND040WHXB1,NASA	SA	1
1-3-8-4	4	A0646	DB93-08805B	ASSY CONNECTOR WIRE-EARTH; DVM INV,EMI EA	SA	1
1-3-9	3	H0034	DB62-10902A	HEAT SINK; FJM,AL,10mm,200,200mm,COUNT-SI	SA	1
1-3-10	3	Z0154	DB93-10809A	ASSY CONNECTOR WIRE-EMI TO MAIN POWER; R	SA	1
1-3-11	3		DB61-04502D	CASE-EMI; RC090MHXEA,HIPS,115,254,NAT,NC0	SA	1