

EXPLODED VIEW PART LIST

Freezer

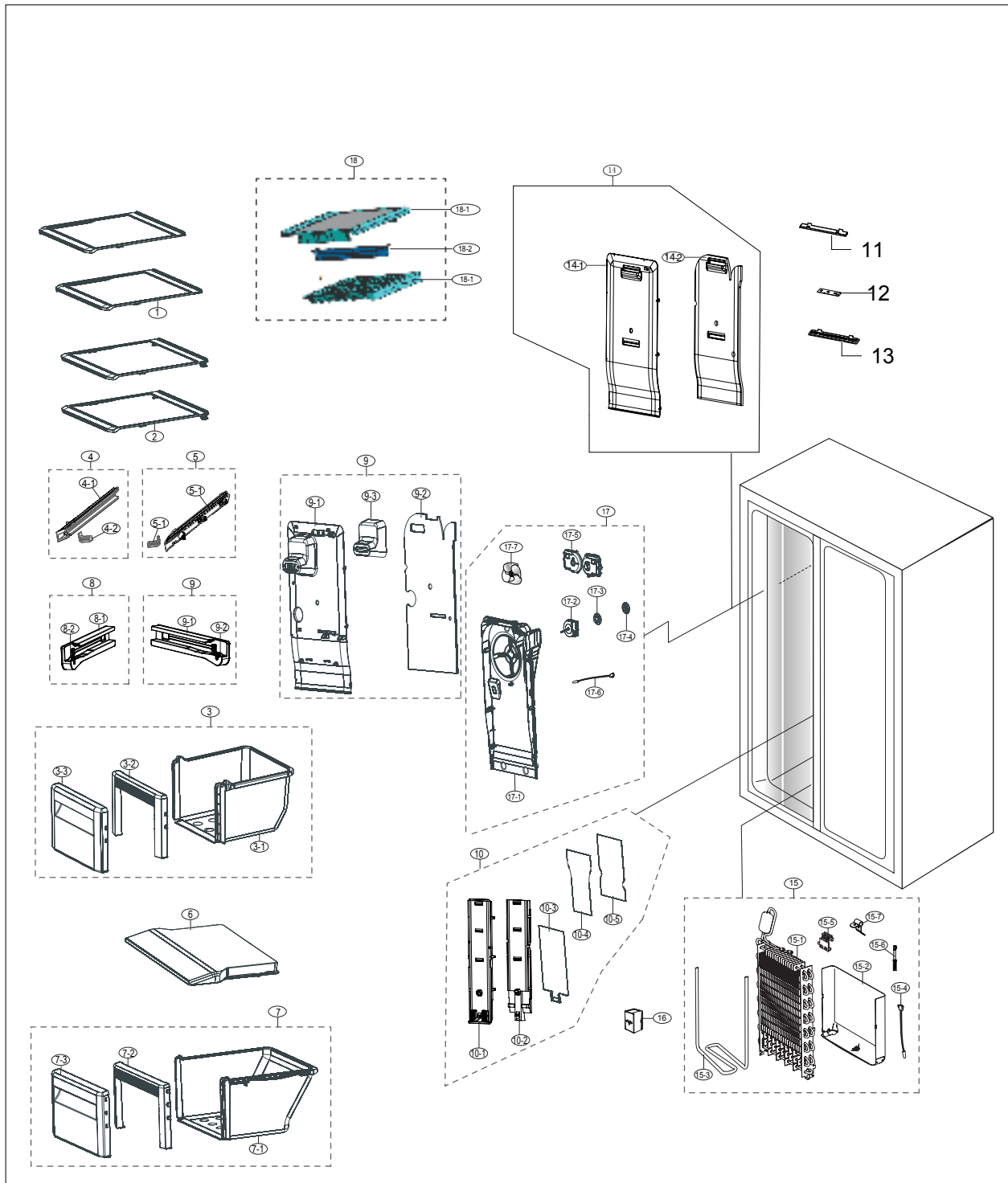

EXPLODED VIEW PART LIST

• Parts List of Freezer

NO	CODE NO	PART NAME	Specification	Quantity	Unit	SA/SNA
1	DA67-03362A	SHELF FRE-HIGH	ES-PJT,SSEC,PP+GLASS,COOL WHITE	2	PC	SA
2	DA67-03363A	SHELF FRE-LOW	ES-PJT,SSEC,PP+GLASS,COOL WHITE	2	PC	SA
3	DA97-14362A	ASSY CASE BASKET-UP	ES-PJT,SSEC	1	PC	SA
3-1	DA61-04009A	CASE-BASKET HIGH	ES-PJT,SSEC,PP	1	PC	SNA
3-2	DA63-04045A	COVER-BASKET FORNT HIGH B	ES-PJT,SSEC,HIPS,COOL WHT	1	PC	SNA
3-3	DA63-04044B	COVER AIR	ES-PJT,SSEC,GPPS,HB,-,PG383M,transparency,BLUE	1	PC	SA
4	DA97-01291B	ASSY RAIL-BASKET L(ET)	ES-PJT,NATURAL	1	PC	SA
4-1	DA61-00044C	RAIL-BASKET L(ET)	ET-PJT,HIPS,NATURAL	1	PC	SNA
4-2	DA63-05275A	GROMMET-RAIL	ES-PJT,SSEC,PA6,SC-93437R	1	PC	SNA
5	DA97-01292B	ASSY RAIL-BASKET R(ET)	ES-PJT,NATURAL	1	PC	SA
5-1	DA61-00045C	RAIL-BASKET R(ET)	ET-PJT,HIPS,NATURAL,S834S1	1	PC	SNA
5-2	DA63-05275A	GROMMET-RAIL	ES-PJT,SSEC,PA6,SC-93437R	1	PC	SNA
6	DA63-03960A	COVER-BASKET HIGH	ES-PJT,SSEC,HIPS,-,-,-,-,COOL WHT,-	1	PC	SA
7	DA97-14363A	ASSY CASE BASKET-LOW	ES-PJT,SSEC	1	PC	SA
7-1	DA61-04046A	CASE-BASKET LOW	ES-PJT,SSEC,PP	1	PC	SNA
7-2	DA63-04042A	COVER-BASKET FRONT LOW B	ES-PJT,SSEC,HIPS,-,-,L298,-,-,COOL WHT,-	1	PC	SNA
7-3	DA63-04040B	COVER AIR	ES-PJT,SSEC,GPPS,HB,-,PG383M,transparency,BLUE	1	PC	SA
8	DA97-04793B	ASSY RAIL-LOW L	N07-PJT,SSEC,L220,NTR	2	PC	SA
8-1	DA61-03078C	RAIL-LOW LEFT	SSEC,HIPS,NTR	1	PC	SNA
8-2	DA66-00420A	ROLLER-RAIL LOW	N07-PJT,SSEC,POM,NTR	1	PC	SA
9	DA97-04794B	ASSY RAIL-LOW R	N07-PJT,SSEC,L220,NTR	2	PC	SA
9-1	DA61-03079C	RAIL-LOW RIGHT	SSEC,HIPS,NTR	1	PC	SNA
9-2	DA66-00420A	ROLLER-RAIL LOW	N07-PJT,SSEC,POM,NTR	1	PC	SA
10	DA97-12129A	ASSY COVER EVAP-FRONT	ES-PJT,SSEC	1	PC	SA
10-1	DA63-06674A	COVER EVAP-FRONT	ES-PJT,SSEC,PP,COOL WHITE	1	PC	SNA
10-2	DA62-03432A	INSULATION-COVER EVAP	ES-PJT,SSEC,PS FOAM	1	PC	SNA
10-3	DA61-04022A	PLATE-HEATER EVAP	ES-PJT,SSEC,GI-SGCC,T0.25	1	PC	SNA
10-4	DA61-04024A	PLATE-INS EVAP	ES-PJT,SSEC,HIPS,T1	1	PC	SNA
10-5	DA02-10005A	TAPE-MASKING	FF Models,PAPER,NTR,W25	0.12	M	SNA
11	DA97-08671B	ASSY CASE LAMP	CC-PJT,ASSY NTR	2	PC	SA
12	DA41-00675J	ASSY LAMP LED	2,CEM-1,110*20,WHITE,SMW250-03G,120mA~160mA,DC12V,MIN 45lx	1	PC	SA
13	DA63-05460B	COVER LAMP	SUPER STAR,GPPS,W35,L145,transparent	1	PC	SA
14	DA97-12130A	ASSY COVER-MULTI FRE FRONT	ES-PJT,ASSY	1	PC	SA
14-1	DA62-03436A	INSULATION-COVER MULTI FRE FRONT	ES-PJT,SSEC,N,W,S,PS FOAM,BASIC	1	PC	SNA
14-2	DA63-06673A	COVER-MULTI FRE FRONT	ES-PJT,SSEC,PP,COOL WHITE,BASIC	1	PC	SNA
15	DA96-00442J	ASSY EVAP-FRE	ES-PJT,ASSY,AL,230V,50Hz,3	1	PC	SA
15-1	DA59-00624A	EVAPORATOR-FRE	Fin Tube,RS5300T,2,A1070,	1	PC	SNA
15-2	DA61-04026A	PLATE DRAIN	ES-PJT,SSEC,GI-SGCC,T0.35	1	PC	SA
15-3	DA47-00279L	HEATER METAL SHEATH	AC230V,ES FRE,176.33	1	PC	SA
15-4	DA32-00024L	SENSOR TEMP	ES-PJT,SSEC,5V,PX-41C,WHT,L2	1	PC	SA
15-5	DA61-00603A	FIXER SENSOR	n-PJT,PP,T2,NATURAL,BJ750	1	PC	SA
15-6	DA47-00301B	THERMO FUSE-ASSY	AC250V,10A,109~110□,S.O	1	PC	SA
15-7	DA61-07451A	PLATE-EVAP HEATER	NW2,AI,T0.7	1	PC	SA

EXPLODED VIEW PART LIST

Fridge

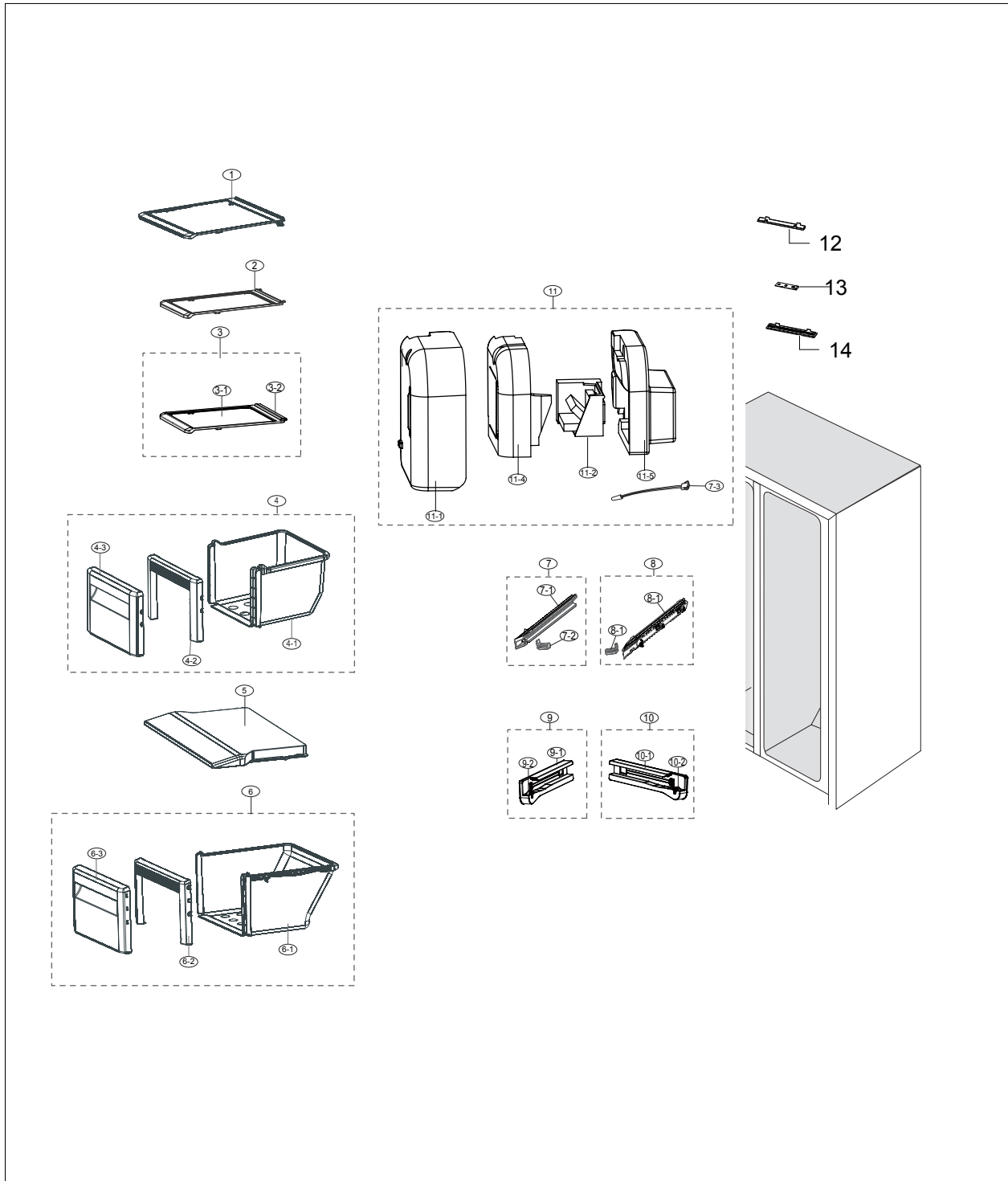

EXPLODED VIEW PART LIST

• Parts List of Fridge

NO	CODE NO	PART NAME	Specification	Quantity	Unit	SA/SNA
1	DA67-03366A	SHELF REF-HIGH	ES-PJT,SSEC,PP+GLASS,COOL WHITE	3	PC	SA
2	DA67-03365A	SHELF REF-LOW	ES-PJT,SSEC,PP+GLASS,COOL WHITE	1	PC	SA
3	DA97-12318A	ASSY SHELF REF-LOW	ES-PJT,SSEC,PP+GLASS	1	PC	SA
3-1	DA67-03365A	SHELF REF-LOW	ES-PJT,SSEC,PP+GLASS,COOL WHITE	1	PC	SA
3-2	DA67-03196B	SHELF-TRIM	ES-PJT,SSEC,PVC,COOL WHITE,PVC	1	PC	SNA
4	DA97-06063B	ASSY CASE VEG-UP	ES-PJT,SSEC	1	PC	SA
4-1	DA61-04037A	CASE-VEG HIGH	ES-PJT,SSEC,PP,COOL WHITE,W380.3,L440.8	1	PC	SNA
4-2	DA63-04036A	COVER VEG-FRONT HIGH B	ES-PJT,SSEC,HIPS,-,W187,L434,-,COOL WHT,-	1	PC	SNA
4-3	DA63-04037C	COVER VEG-FRONT UP A	ES-PJT,SSEC,GPPS,HB,-,PG383M,Transparency,BLUE	1	PC	SNA
5	DA63-04053A	COVER VEG-HIGH	ES-PJT,SSEC,HIPS,W343,L439.8,COOL WHT	1	PC	SA
6	DA97-06064B	ASSY CASE VEG-LOW	ES-PJT,SSEC	1	PC	SA
6-1	DA61-04036A	CASE-VEG LOW	ES-PJT,SSEC,PP,W366,L429,COOL WHT	1	PC	SNA
6-2	DA63-04029A	COVER VEG-FRONT LOW B	ES,HIPS,COOL WHITE	1	PC	SNA
6-3	DA63-04031B	COVER VEG-FRONT LOW A	ES-PJT,SSEC,GPPS,HB,-,PG383M,Transparency,BLUE	1	PC	SNA
7	DA97-01291B	ASSY RAIL-BASKET L(ET)	ES-PJT,NATURAL	1	PC	SA
7-1	DA61-00044C	RAIL-BASKET L(ET)	ET-PJT,HIPS,NATURAL	1	PC	SNA
7-2	DA63-05275A	GROMMET-RAIL	ES-PJT,SSEC,PA6,SC-93437R	1	PC	SNA
8	DA97-01292B	ASSY RAIL-BASKET R(ET)	ES-PJT,NATURAL	1	PC	SA
8-1	DA61-00045C	RAIL-BASKET R(ET)	ET-PJT,HIPS,NATURAL,S834S1	1	PC	SNA
8-2	DA63-05275A	GROMMET-RAIL	ES-PJT,SSEC,PA6,SC-93437R	1	PC	SNA
9	DA97-04793B	ASSY RAIL-LOW L	N07-PJT,SSEC,L220,NTR	2	PC	SA
9-1	DA61-03078C	RAIL-LOW LEFT	SSEC,HIPS,NTR	1	PC	SNA
9-2	DA66-00420A	ROLLER-RAIL LOW	N07-PJT,SSEC,POM,NTR	1	PC	SA
10	DA97-04794B	ASSY RAIL-LOW R	N07-PJT,SSEC,L220,NTR	2	PC	SA
10-1	DA61-03079C	RAIL-LOW RIGHT	SSEC,HIPS,NTR	1	PC	SNA
10-2	DA66-00420A	ROLLER-RAIL LOW	N07-PJT,SSEC,POM,NTR	1	PC	SA
11	DA97-12132B	ASSY COVER DAMPER-REF	ES-PJT,COOL WHITE	1	PC	SA
11-1	DA63-06675A	COVER DAMPER-REF	ES-PJT,SSEC,11,PP,COOL WHT	1	PC	SNA
11-2	DA31-00071C	MOTOR GEARED DC DAMPER	NSY002TD1,DC 12V,60mA,200mm / Heater Type	1	PC	SC
11-3	DA32-00066H	SENSOR TEMP	MT12,-50~80□,5V,PBA CAP, 502	1	PC	SA
11-4	DA62-03433A	INSULATION-DAMPER REF UP	ES-PJT,SSEC,PS FOAM	1	PC	SNA
11-5	DA62-03434A	INSULATION-DAMPER REF LOW	ES-PJT,SSEC,PS FOAM	1	PC	SA
12	DA97-08671B	ASSY CASE LAMP	CC-PJT,ASSY NTR	1	PC	SA
13	DA41-00675J	ASSY LAMP LED	2,CEM-1,110*20,WHITE,SMW250-03G,120mA~160mA,DC12V,MIN 45lx	1	PC	SA
14	DA63-05460B	COVER LAMP	SUPER STAR,GPPS,W35,L145,transparent	1	PC	SA

EXPLODED VIEW PART LIST

Cabinet

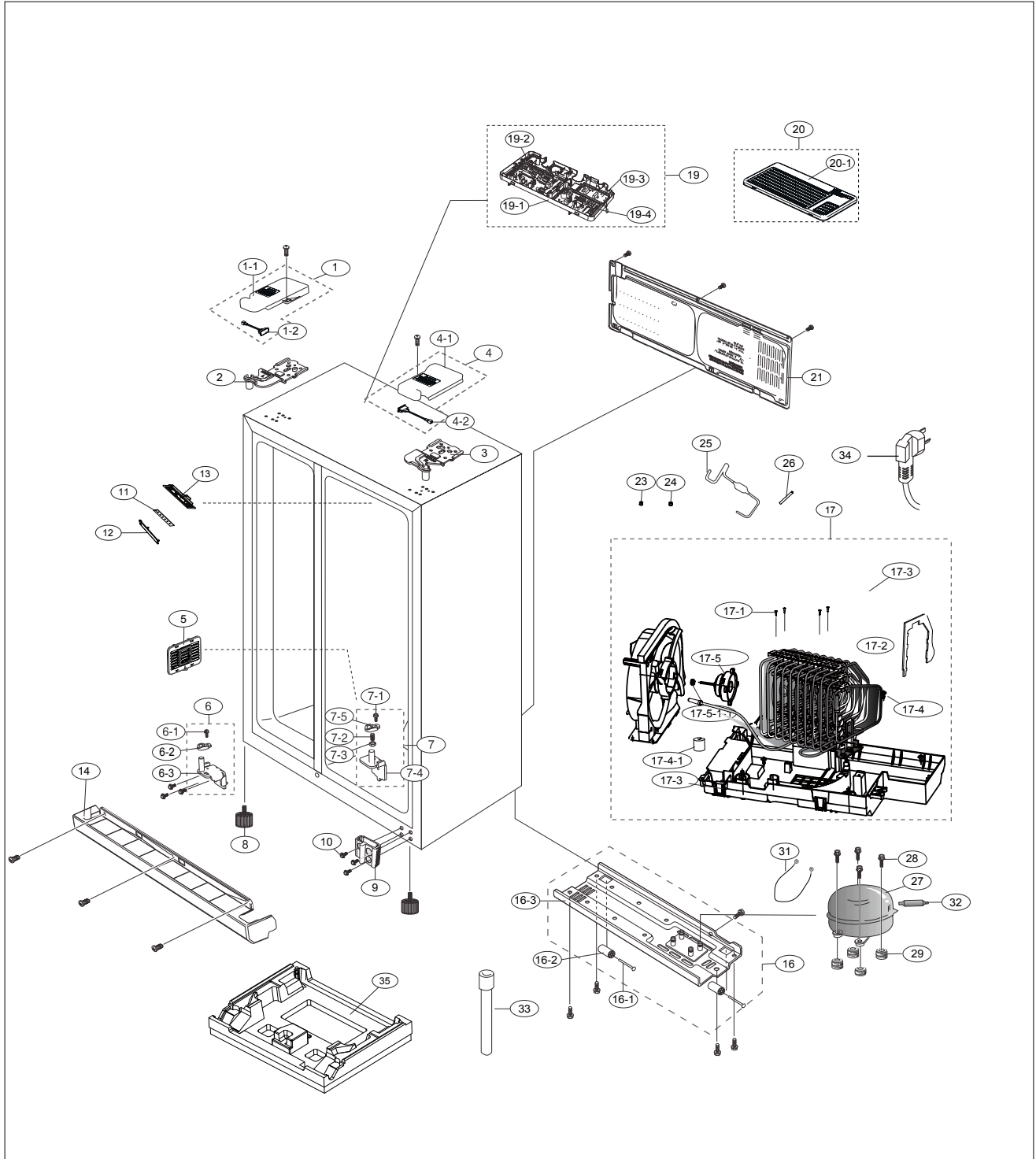

EXPLODED VIEW PART LIST

• Parts List of Cabinet

NO	CODE NO	PART NAME	Specification	Quantity	Unit	SA/SNA
1	DA97-14174K	ASSY COVER HINGE-UP LEFT	ES-PJT,HIPS,TAPE-AL FOIL,INOX GRAY(GY0034)	1	PC	SA
1-1	DA63-03958K	COVER HINGE-UPP L	ES,HIPS,INOX 2008(DY0034)	1	PC	SA
1-2	DA34-00043J	SWITCH REED	UL1007 AWG 22,50mm	1	PC	SA
2	DA61-03933A	HINGE-UPP L	ES-PJT,SSEC,SHP1,T3.0,-,-,BLACK,-,-	1	PC	SA
3	DA61-03932A	HINGE-UPP R	ES-PJT,SSEC,SHP1,T3.0,-,-,BLACK,-,-	1	PC	SA
4	DA97-14175K	ASSY COVER HINGE-UP RIGHT	ES-PJT,HIPS,TAPE-AL FOIL,INOX GRAY(GY0034)	1	PC	SA
4-1	DA63-03959K	COVER HINGE-UPP R	ES-PJT,SSEC,HIPS,INOX 2008(DY0034)	1	PC	SNA
4-2	DA34-00043J	SWITCH REED	UL1007 AWG 22,50mm	1	PC	SA
5	DA63-01077C	COVER-PURIFIER	ES,2008GVE,HIPS,NTR	1	PC	SA
6	DA97-05765A	ASSY HINGE LOW-L	ES-PJT,SSEC,T4.5,W80.4,L57.8,-,-,-	1	PC	SNA
6-1	6003-001435	SCREW-TAPTYPE	HWH,+S,M5,L12.7,ZPC2(WHT),SWCH22AKILLED STEEL(1018K)	1	PC	SNA
6-2	DA66-00343A	CAM-RISER	USP05(ATOP,ET),PA66,BLACK	1	PC	SNA
6-3	DA61-03941A	HINGE-LOW L	ES-PJT,SSEC,CR-SPCC,T4.5,B	1	PC	SC
7	DA97-01763A	ASSY HINGE LOW R	A-TOP,BASIC,10.5 Gasket,-,-,-,-	1	PC	SC
7-1	6003-001435	SCREW-TAPTYPE	HWH,+S,M5,L12.7,ZPC2(WHT),SWCH22AKILLED STEEL(1018K)	1	PC	SNA
7-2	6011-001442	BOLT-SOCKET	M8,L13.4,ZPC(BLK),SCM435,4mm,FE-FZB	1	PC	SNA
7-3	6021-001125	NUT-HEXAGON	3,M8,ZPC(WHT),SWCH10A	1	PC	SNA
7-4	DA61-01608A	HINGE-LOW REF	ES-PJT,SSEC,CR-SPCC,T4.5,B,A-TOP	1	PC	SNA
7-5	DA66-00343A	CAM-RISER	USP05(ATOP,ET),PA66,BLACK	1	PC	SNA
8	DA61-30102D	FOOT-FRONT	ES,PP,BLACK,0103-002776,N	2	PC	SA
9	DA61-03151C	BRACKET HINGE-LOW	ES-PJT,AI	1	PC	SNA
10	DA60-10123C	BOLT-HEX	M6,L24,ZPC(WHT),SWRCH18A,HWH Head, 1018K	6	PC	SA
11	DA41-00675J	ASSY LAMP LED	2,CEM-1,110*20,WHITE,SMW250-03G,120mA~160mA,DC12V,MIN 45lx	2	PC	SA
12	DA63-05460B	COVER LAMP	SUPER STAR,GPSS,W35,L145,transparent	1	PC	SA
13	DA97-08671B	ASSY CASE LAMP	CC-PJT,ASSY NTR	2	PC	SA
14	DA63-09312A	COVER LEG-FRONT	ES FACELIFT,PP,T2.5,INOX GRAY	1	PC	SA
15	DA61-02514B	CASTER-FRONT	RF5500,PP	1	PC	SA
16	DA97-05772C	ASSY CHASSIS-COMP	ES-PJT,SSEC,GVE,-,T1.2,-,-,-,-	1	PC	SA
16-1	DA60-90146A	PIN-CASTER	SR-289-429,MSWR,L38,ZPC2	2	PC	SNA
16-2	DA61-00190A	CASTER	SR-32,PP,-,-,-,-,WHIRLPOOL	2	PC	SNA
16-3	DA64-02381C	CHASSIS COMP	ES-PJT,SSEC,SGCC,T1,-,GVE,HGI	1	PC	SNA
17	DA97-19328A	ASSY TRAY DRAIN WATER	ES,matching new C-fan DA31-00278C	1	PC	SA
17-1	DA60-10130B	SCREW-TAPPING	TH,-,-,M4.2,L13,ZPC(WHT),SWRCH18A,-,-	2	PC	SA
17-2	DA62-01833J	SEAL CUTT-FOAM LEX	ES-PJT,LEX FOAM,T3,W30,L1000,ADHESIVE	0.9	M	SNA
17-3	DA63-09380A	TRAY DRAIN-WATER	ES17FACELIFT,PP,T1.5,BLACK,SCRAP	1	PC	SNA
17-4	DA97-11678B	ASSY CONDENSER-SUB	STEEL,WIRE	1	PC	SA
17-4-1	DA63-40128A	GROMMET-SUB COND	-,NBR,-,-,-,-,-,DARK-GRAY	2	PC	SA
17-5	DA97-15765A	ASSY SUPPORT-CIRCUIT MOTOR	C 160I	1	PC	SA
17-5-1	DA61-20128A	SPRING ETC-FAN	STS304,PI8.8,ID7.8,OD9.8,L5.0,FD	1	PC	SA
18	DA60-10124A	BOLT-HEX	M6,L16,ZPC(WHT),SWRCH18A,HWH Head	4	PC	SA

EXPLODED VIEW PART LIST

• Parts List of Cabinet

NO	CODE NO	PART NAME	Specification	Quantity	Unit	SA/SNA
19	DA97-15180W	ASSY CASE PCB-MAIN	RS54N3103SA/EU,GRY,EN	1	PC	SNA
19-1	DA61-03917A	CASE PCB-PANEL	ES,PP,GRAY,MANHATTAN SILV	1	PC	SA
19-2	DA92-01114C	ASSY PCB MAIN	S OPTION,0x36,ES face lift	1	PC	SA
19-3	DA27-00027G	COIL FILTER	14mH,82*60,5A,0.68uF,1500pF,220V,SURGE_ ABSORBER	1	PC	SNA
19-4	DA92-00768E	ASSY PCB INVERTER	INVERTER,HM12,197*98.5,Y,220V,15V, 5V,F3_AL,Y	1	PC	SA
20	DA97-15326A	ASSY COVER PCB-PANEL	super star,ASSY	1	PC	SA
20-1	DA63-03963A	COVER PCB-PANEL	ES-PJT,SSEC,SBHG1,T0.4,W264.1,L520.1,-,-,-,-	1	PC	SA
21	DA97-06758F	ASSY COVER COMP	ES10-PJT,SSEC,T0.4,INVERTER	1	PC	SA
23	DA60-00280A	FITTING-LOKRING 33	SUM23,33, 11SMnPb30K	1	PC	SA
24	DA60-00281A	FITTING LOKRING	SUM23,1D5.02,11SMnPb30K,St 56	1	PC	SNA
25	DA97-06571B	ASSY PIPE CONNECT-SUCT	ES-PJT,SSEC,INVERTER,C1220T	1	PC	SA
26	DA73-00050G	PIPE-CONN	Cu,OD6.35,T0.6	1	PC	SA
27	NF34J9151ANSJ3	CMP,COMP,REFRIGERATOR,R-600A	0	1	PC	-
28	6011-004061	BOLT-HEX	M6,L43.6,SWRCH10A	4	PC	SA
29	DA63-02617C	GROMMET COMP	NN34J9902AP,IIR,BLACK,H28.3	4	PC	SA
30	DA60-90124A	RIVET	MSWR,L56	1	PC	SA
31	DA39-20389L	ASSY WIRE HARNESS-EARTH	ALL,FREE VOLT,UL+IEC,UL,ALL,EARTH,150mm,1, ST710489-3*2	1	PC	SA
32	DA62-01469H	DRYER	C1220T-H,115,SINGLE MOUTH	1	PC	SA
33	DA97-19346A	ASSY CAP DRAIN	ES 17FaceLift,ASSY	1	PC	SA
33-1	DA67-01301A	CAP-DRAIN	AW4,HIPS,HB,S834S1,NATURAL	1	PC	SA
34	DA96-00929A	CBF-POWER CORD	Black,2000	1	PC	SA
35	DA99-03667A	ASSY CUSHION BOTTOM	ES-PJT,L958,W761	1	PC	SA
37	DA60-00279A	FITTING-LOKRING 16	SUM23,16, 11SMnPb30K	1	PC	SA

EXPLODED VIEW PART LIST

Freezer Door

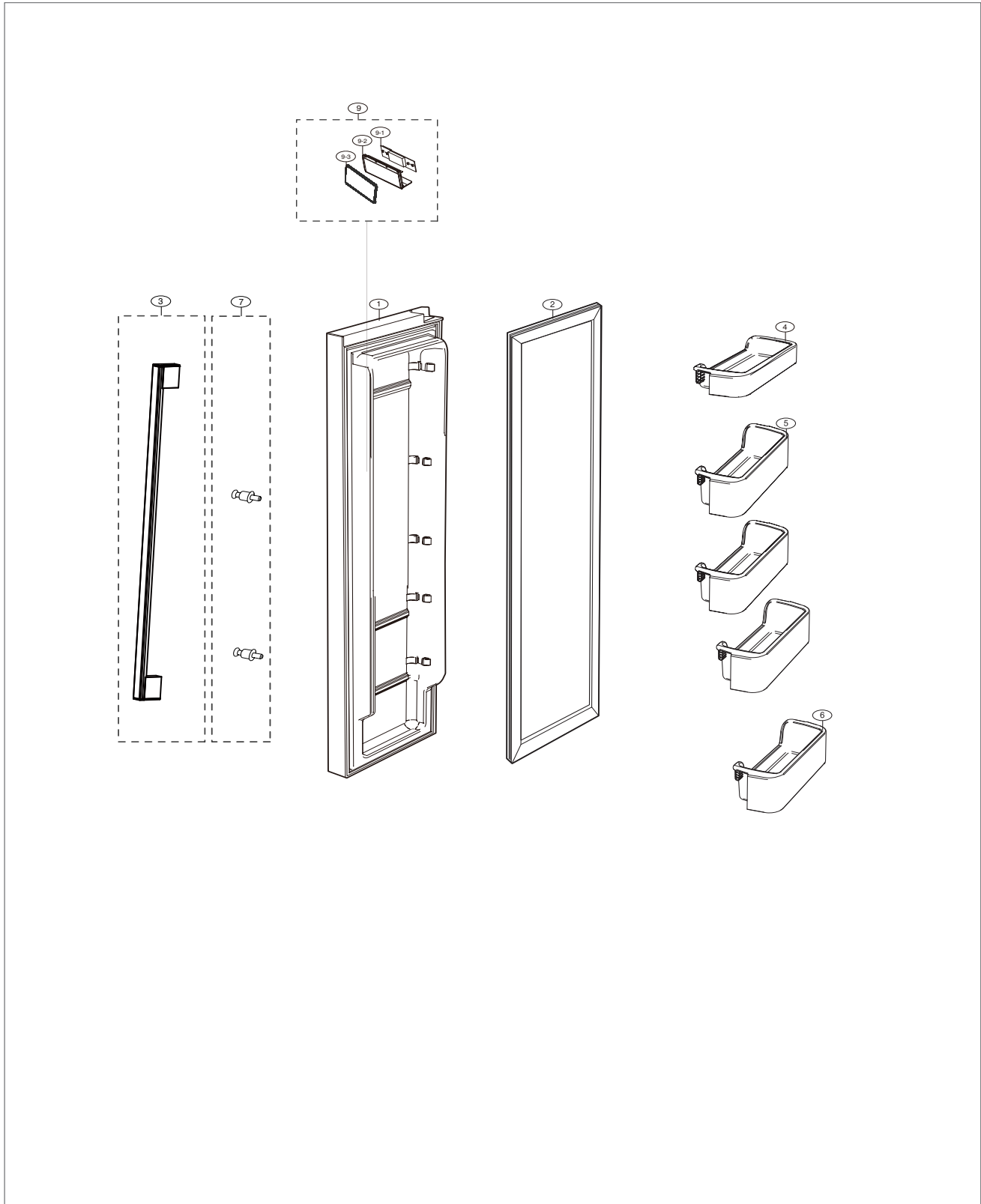

EXPLODED VIEW PART LIST

• Parts List of Freezer Door

NO	CODE NO	PART NAME	Specification	Quantity	Unit	SA/SNA
1	DA91-05148G	ASSY DOOR FOAM-FRE	ES FACE LIFT,METAL GR	1	PC	SA
2	DA63-07738A	GASKET DOOR-FRE	ES-PJT,PVC,GRAY	1	PC	SA
3	DA97-11103J	ASSY HANDLE BAR	NW2,AL,STS	1	PC	SA
4	DA97-07426C	ASSY GUARD-FRE UP	ES09-PJT,GPPS+HIPS	1	PC	SA
5	DA97-07427C	ASSY GUARD-FRE LOW	ES09-PJT,GPPS+HIPS	3	PC	SA
6	DA97-07427D	ASSY GUARD-FRE LOW	ES10,ES GLASS,GPPS+HIPS	1	PC	SA
7	DA61-06887A	FIXER-HANDLE	ES10,N10-PJT,SSEC,POM,NTR	2	PC	SA
8	DA61-03949A	MAGNET	ES-PJT,SSEC,FERRITE,1600Gauss	1	PC	SA
9	DA97-15848B	ASSY COVER CONTROL	ES-face lift,N-option,VACATION	1	PC	SA
9-1	DA41-00535J	ASSY MODULE	ASSY PCB KIT LED,ES-PJT,EN,W32,T1.6,L217.6,VOCA TION,Ice Blue	1	PC	SA
9-2	DA63-08189A	COVER DISPLAY	ES-PJT Face Lift,ABS,INOX GRAY,N-OPTION	1	PC	SNA
9-3	DA64-04877B	INLAY-CONTROL	ES-FACE LIFT,PC,T0.38,N-OPTION,VACATION	1	PC	SNA

EXPLODED VIEW PART LIST

Fridge Door

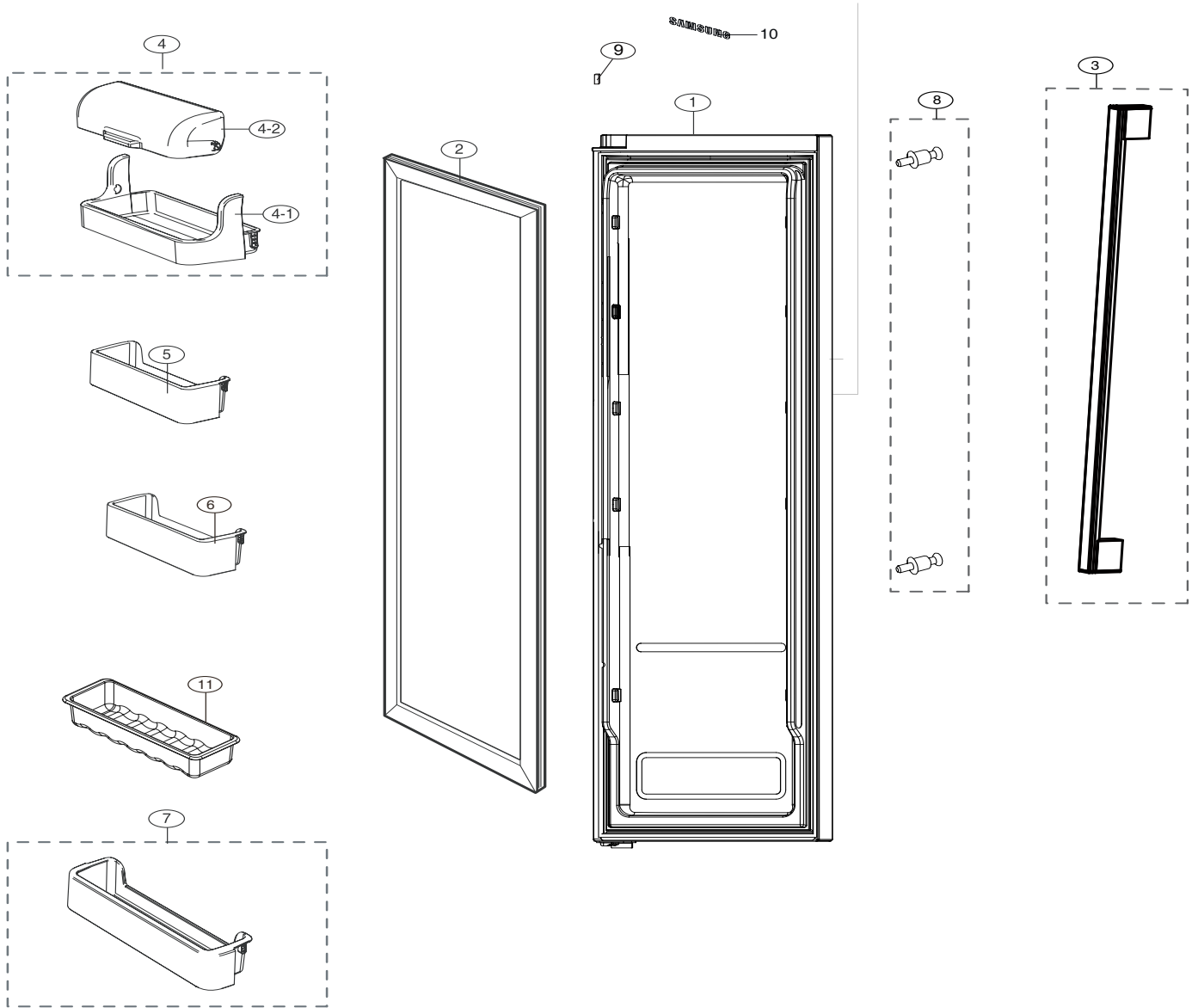

EXPLODED VIEW PART LIST

• Parts List of Fridge Door

NO	CODE NO	PART NAME	Specification	Quantity	Unit	SA/SNA
1	DA91-05148A	ASSY DOOR FOAM-REF	ES FACE LIFT,METAL GR	1	PC	SA
2	DA63-07739A	GASKET DOOR-REF	ES-PJT,PVC,GRAY	1	PC	SA
3	DA97-11103J	ASSY HANDLE BAR	NW2,AL,STS	1	PC	SA
4	DA97-07428B	ASSY GUARD DAIRY	ES09-PJT,SSEC	1	PC	SA
5	DA97-07429B	ASSY GUARD-REF UP	ES09-PJT,GPPS+HIPS	1	PC	SA
6	DA97-07430B	ASSY GUARD-REF MIDDLE	ES09-PJT,GPPS+HIPS	1	PC	SA
7	DA97-07431B	ASSY GUARD-REF LOW	ES09-PJT,GPPS+HIPS	1	PC	SA
8	DA61-06887A	FIXER-HANDLE	ES10,N10-PJT,SSEC,POM,NTR	2	PC	SA
9	DA61-03949A	MAGNET	ES-PJT,SSEC,FERRITE,1600Gauss	1	PC	SA
10	DA64-04021A	MASCOT	ALL,Ni,T0.06,L90	1	PC	SA
11	DA63-06420A	TRAY EGG	NW2-PJT,SSEC,GPPS,-,-,TP BLUE	1	PC	SA
12	DA97-00713C	ASSY-THERMO GUIDE	XEF,THERMO,COOL WHITE	1	PC	SA