

DAEWOO
ELECTRONICS



RCP33**/36**
RCT33**/36**



DAEWOO
ELECTRONICS



Contents

1. Warmings and Precautions for Safety ----- 2

2. Product Specification ----- 3

3. Wiring Diagram ----- 5

4. Product Size and Features ----- 14

5. Cooling Cycle ----- 19

6. Product Control Information ----- 20

7. Disassembly / Assembly Guide of Each Part ----- 40

8. Exploded View and SVC Parts List ----- 47

1. Warmings and Precautions for Safety

Please observe the following safety precautions in order to use safely and correctly the refrigerator and to prevent accident and danger during repair.

- 1) Be care of an electric shock. Disconnect power cord from wall outlet and wait for more than three minutes before replacing PCB parts.
Shut off the power whenever replacing and repairing electric components.
- 2) When connecting power cord, please wait for more than five minutes after power cord was disconnected from the wall outlet.
- 3) Please check if the power plug is pressed down by the refrigerator against the wall.
If the power plug was damaged, it may cause fire or electric shock.
- 4) If the wall outlet is over loaded, it may cause fire.
Please use its own individual electrical outlet for the refrigerator.
- 5) Please make sure the outlet is properly earthed, particularly in wet or damp area.
- 6) Use standard electrical components when replacing them.
- 7) Make sure the hook is correctly engaged.
Remove dust and foreign materials from the housing and connecting parts.
- 8) Do not fray, damage, machine, heavily bend, pull out or twist the power cord.
- 9) Please check the evidence of moisture intrusion in the electrical components.
Replace the parts or mask it with insulation tapes if moisture intrusion was confirmed.
- 10) Do not touch the icemaker with hands or tools to confirm the operation of geared motor.
- 11) Do not let the customers repair, disassemble and reconstruct the refrigerator for themselves.
It may cause accident, electric shock, or fire.
- 12) Do not store flammable materials such as ether, benzene, alcohol, chemicals, gas, or medicine in the refrigerator.
- 13) Do not put flower vase, cup, cosmetics, chemicals, etc., or container with full of water on the top of the refrigerator.
- 14) Do not put glass bottles with full of water into the freezer.
The contents shall freeze and break the glass bottles.
- 15) When you scrap the refrigerator, please disconnect the door gasket first and scrap it where children are not accessible.

2. Product Specification

2-1. Specification

ITEM		SPEC			
Model Name		RCP33**	RCP36**	RCT33**	RCT36**
Volume	Total	337L	362L	337L	362L
	Freezer	92L			
	Refrigerator	245L	270L	245L	270L
External Dimension (mm) (Width * Depth * Height) (w/o Handle)		595 * 667 * 1897	595 * 667 * 2000	595 * 667 * 1897	595 * 667 * 2000
Voltage / Frequency		220~240V / 50Hz			
Rated Input		95 W			
Cooling Type		In-direct Cooling			
Refrigerant		R-600a / 40g (A+), 38g (A++)			
Climate Class		SN ~ T			
Weight		69Kg	72Kg	74.5Kg	78Kg

2-2. Electrical Inlet Specification

ITEM		SPEC		
Model Name		RCP3*** / RCT3***		
Cooling Components	Comp	Name	TH1114Y1(A+), LR88CY1(A++)	
		Oil	MINERAL OIL, 160ml(TH1114Y1) / 200ml(LR88CY1)	
	Evaporator	Fin Type		
	Condenser	Fan Cooling Type		
	Dryer	MOLECULAR SIEVE XH-9		
	Capillary Tube	IDΦ0.7 X 0.55t X L2,320		
	Refrigerant	R-600a		
	O L P	Name	B52-120/B(TH1114Y1) / BT60-105/V(LR88CY1)	
		Open Temp	120℃ ± 5	
		Close Temp	61℃ ± 9	
Defrosting Components	Defrost Heater	AC230V / 160W		
	D-Sensor (Name / Return Temp)	PRE303F31GA-DWR06 / 13℃		
	Temp Fuse	250V / 10A / 77 (+0,-4)℃		

ITEM		SPEC
Model Name		RCP3*** / RCT3***
Electric Components	Main Fuse	AC250V /4A
	Freezer Fan Motor	D4612AAA41, DC12V / ϕ 110
	Condenser Fan Motor	D4612AAA39, DC12V / ϕ 130
	Refrigerator Lamp	LED (DC12V / 0.6W)
	Refrigerator Door Switch	HC-050K4 (AC 250 V, 2.5A)
	Power Code	AC250V /16A
	F/R Sensor	REB303F31GA-DW / REB303F31GA

2-3. Refrigerator Control Temperature

REFRIGERATOR		
STEP	DISPLAY	ON / OFF
Min	LED "1 Section" lighting	8.1 / 1.5
Min-Mid	LED "2 Section" lighting	5.8 / -0.6
Mid	LED "3 Section" lighting	4.6 / -1.7
Mid-Max	LED "4 Section" lighting	2.5 / -3.7
Max	LED "5 Section" lighting	1.4 / -4.8

3. Wiring Diagram

3-1. RCP3*** Model (Metal Door)

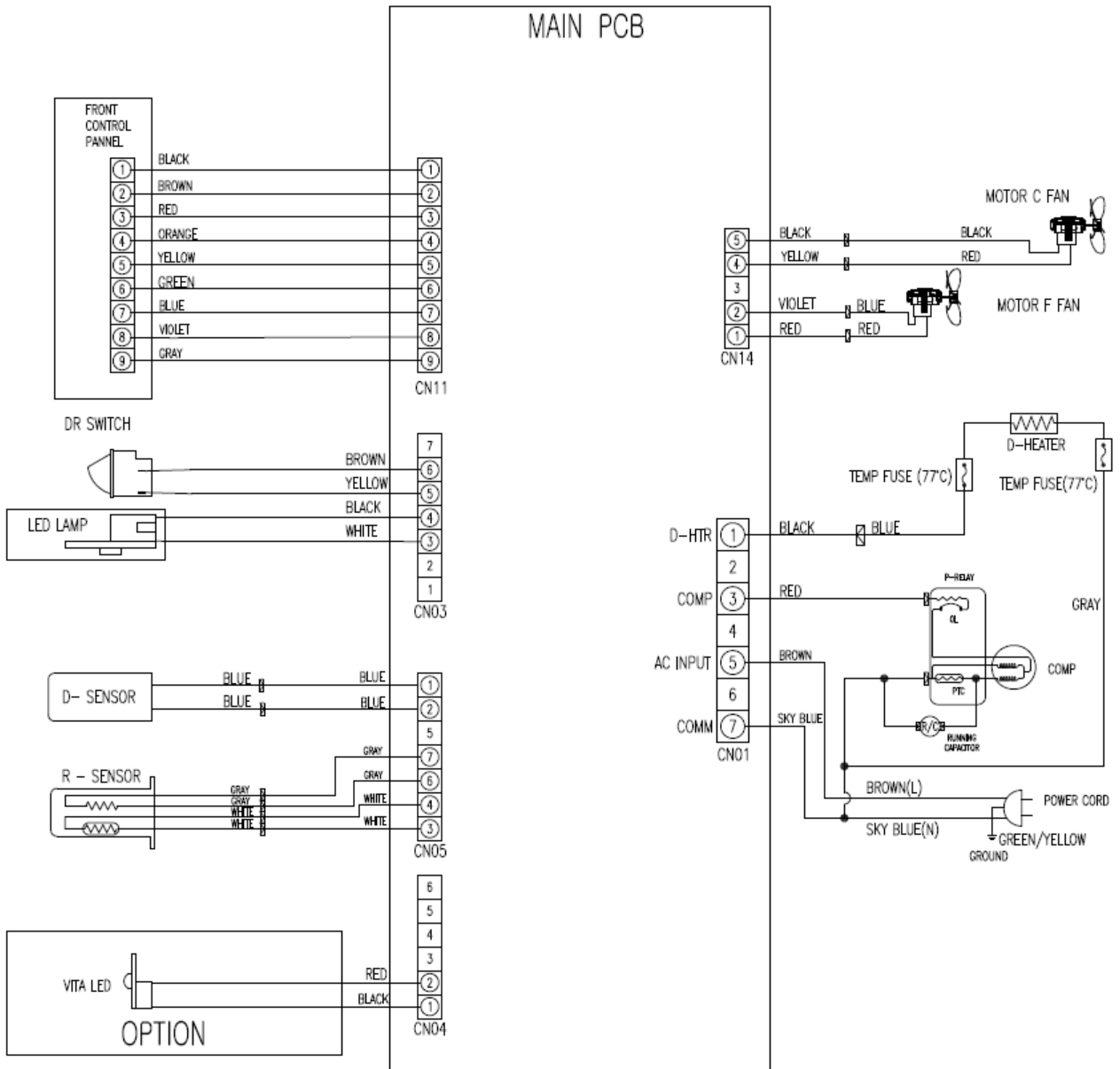

3-2. RCT3*** Model (Glass Door)

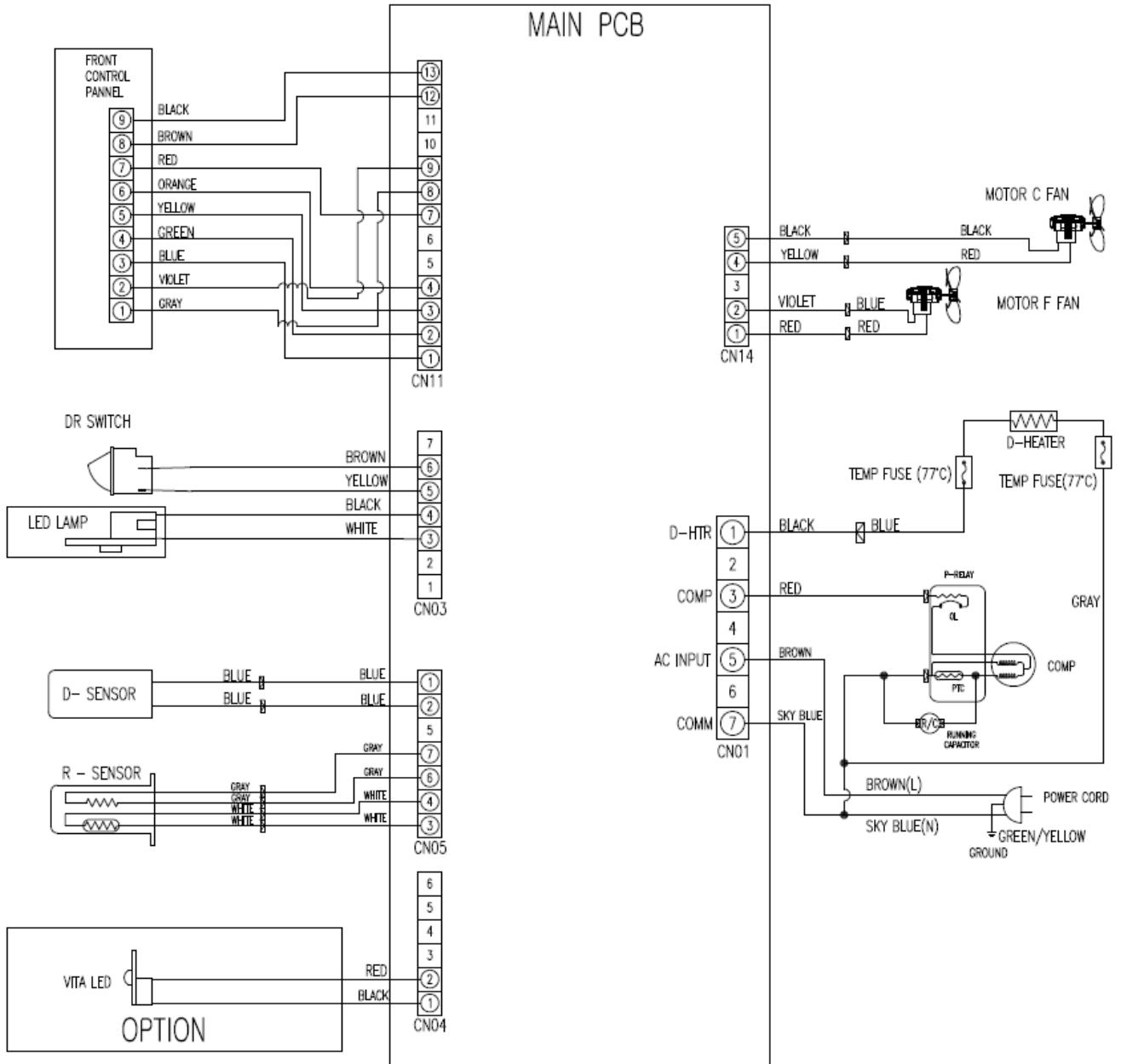

3-3. Main PCB Circuit Diagram

<SMPS Part>

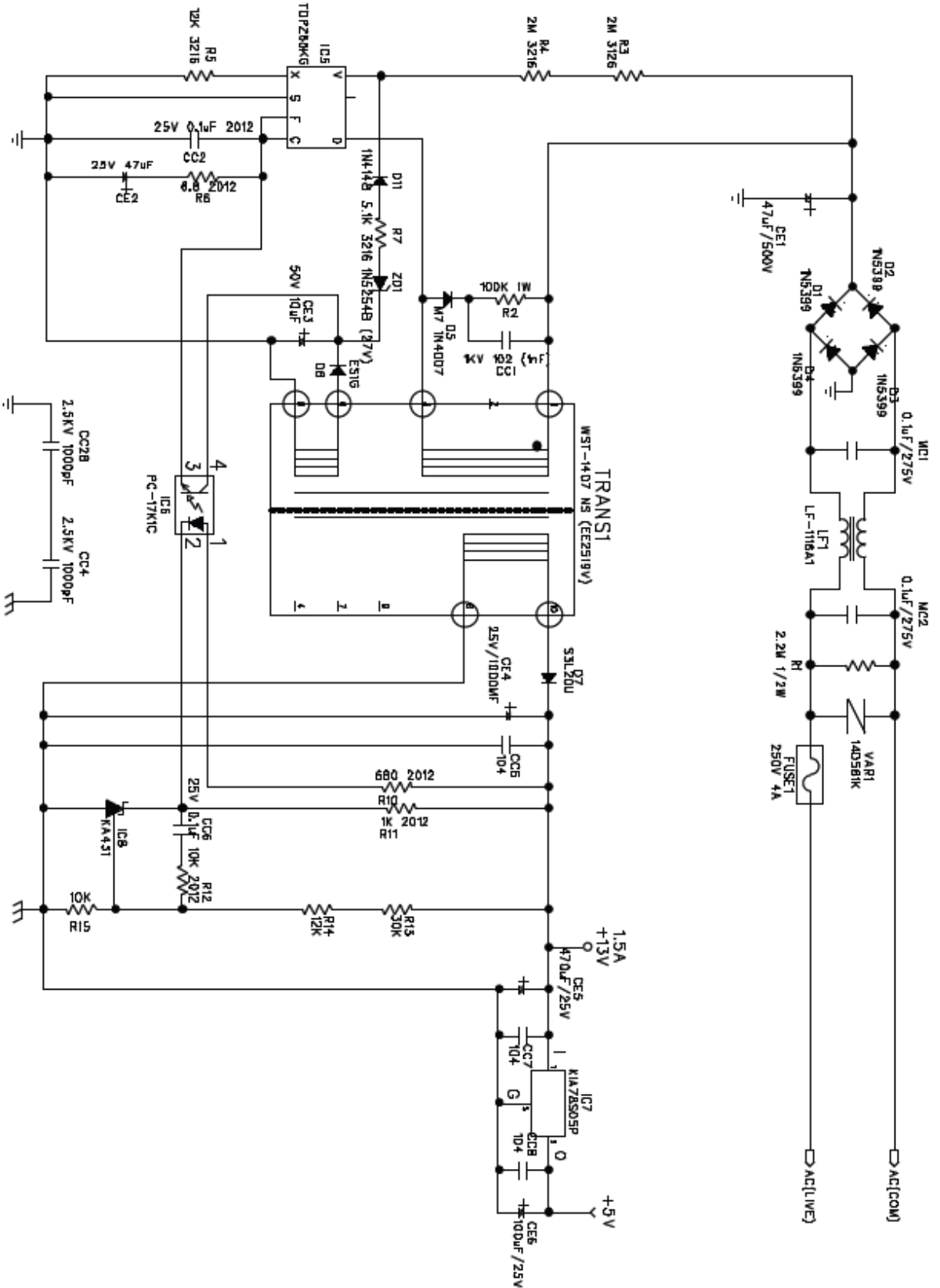

3-3. Main PCB Circuit Diagram

<MCU Part>

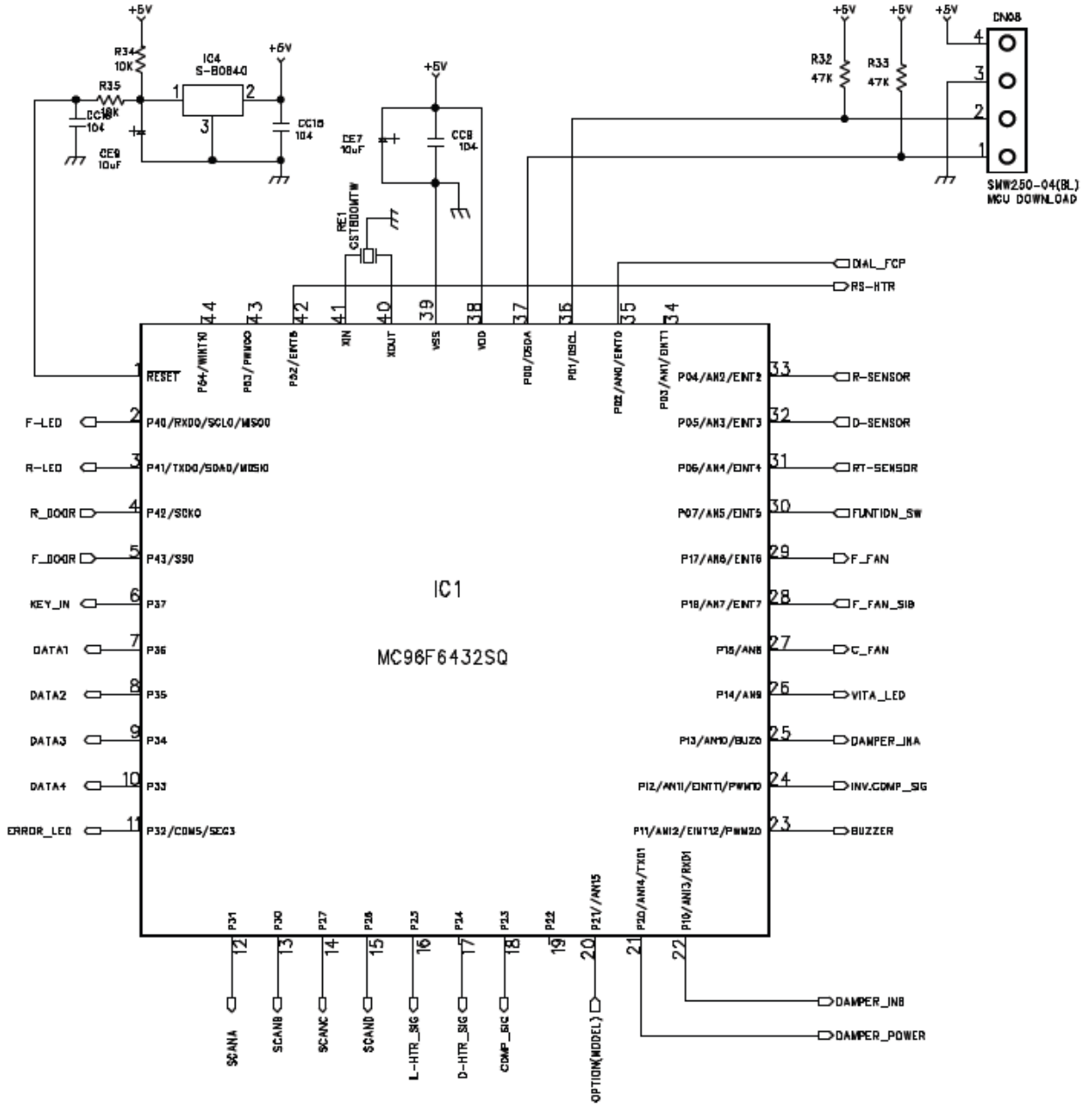

<Error LED>

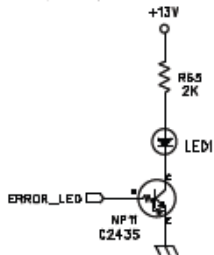

<Option Part>

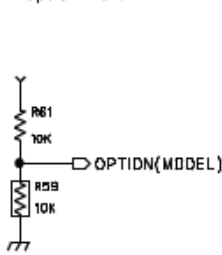

<Function S/W Part>

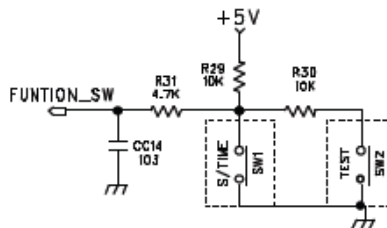

<Buzzer Part>

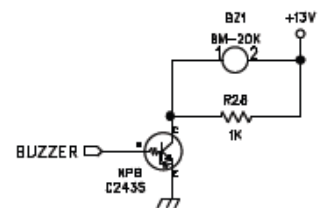

3-3. Main PCB Circuit Diagram

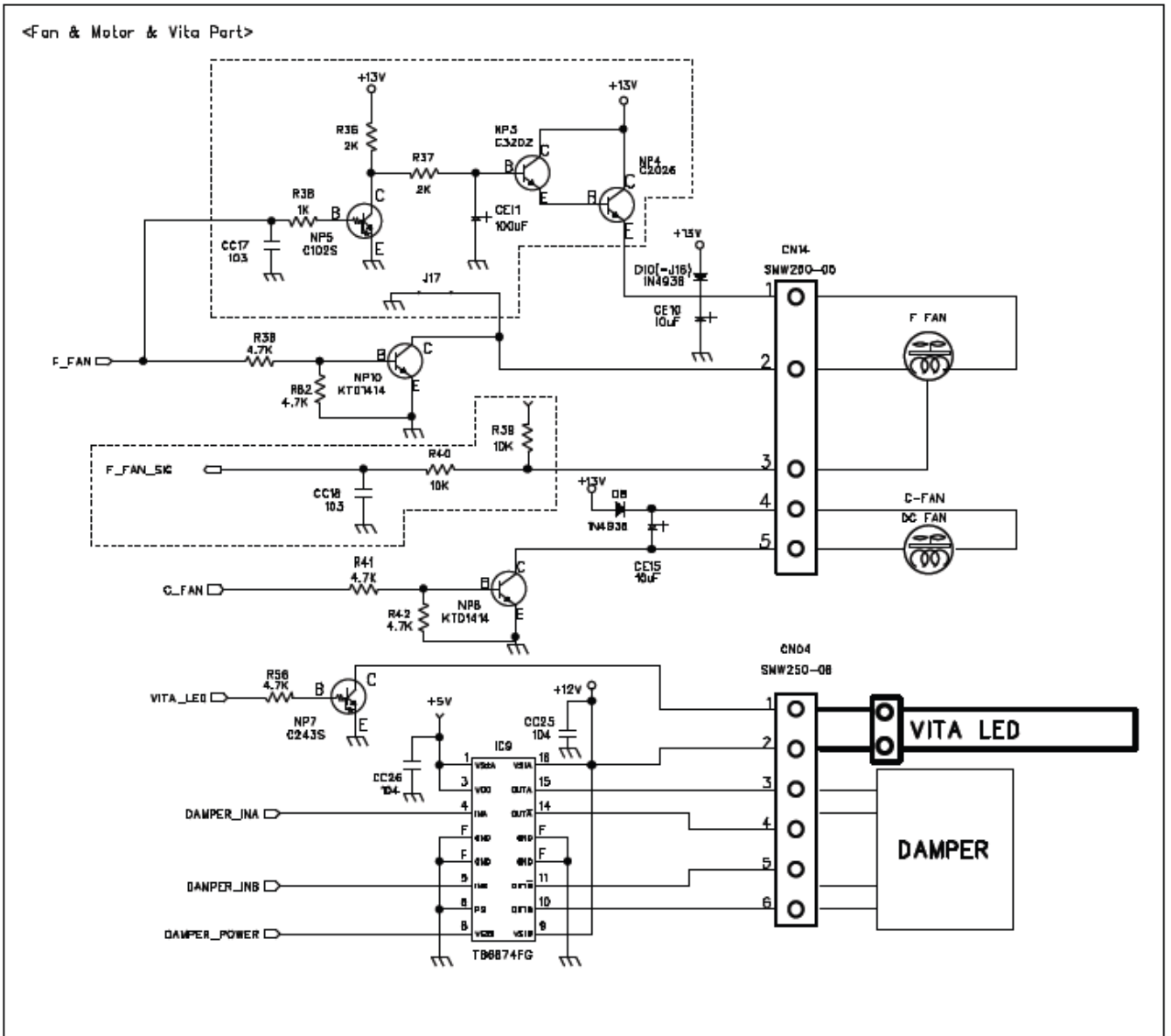
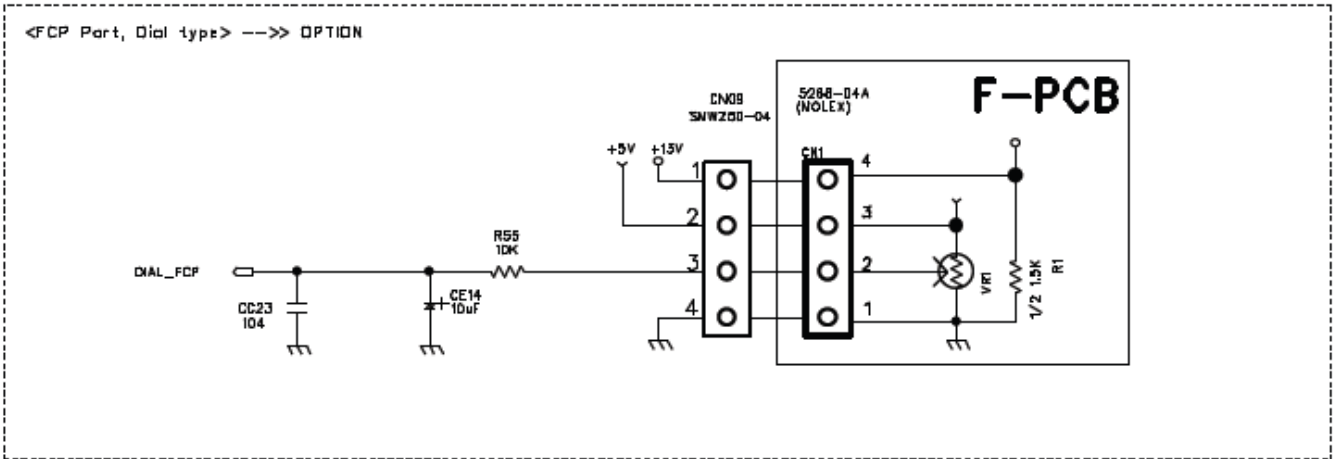

3-3. Main PCB Circuit Diagram

<Relay & Inv.comp Part>

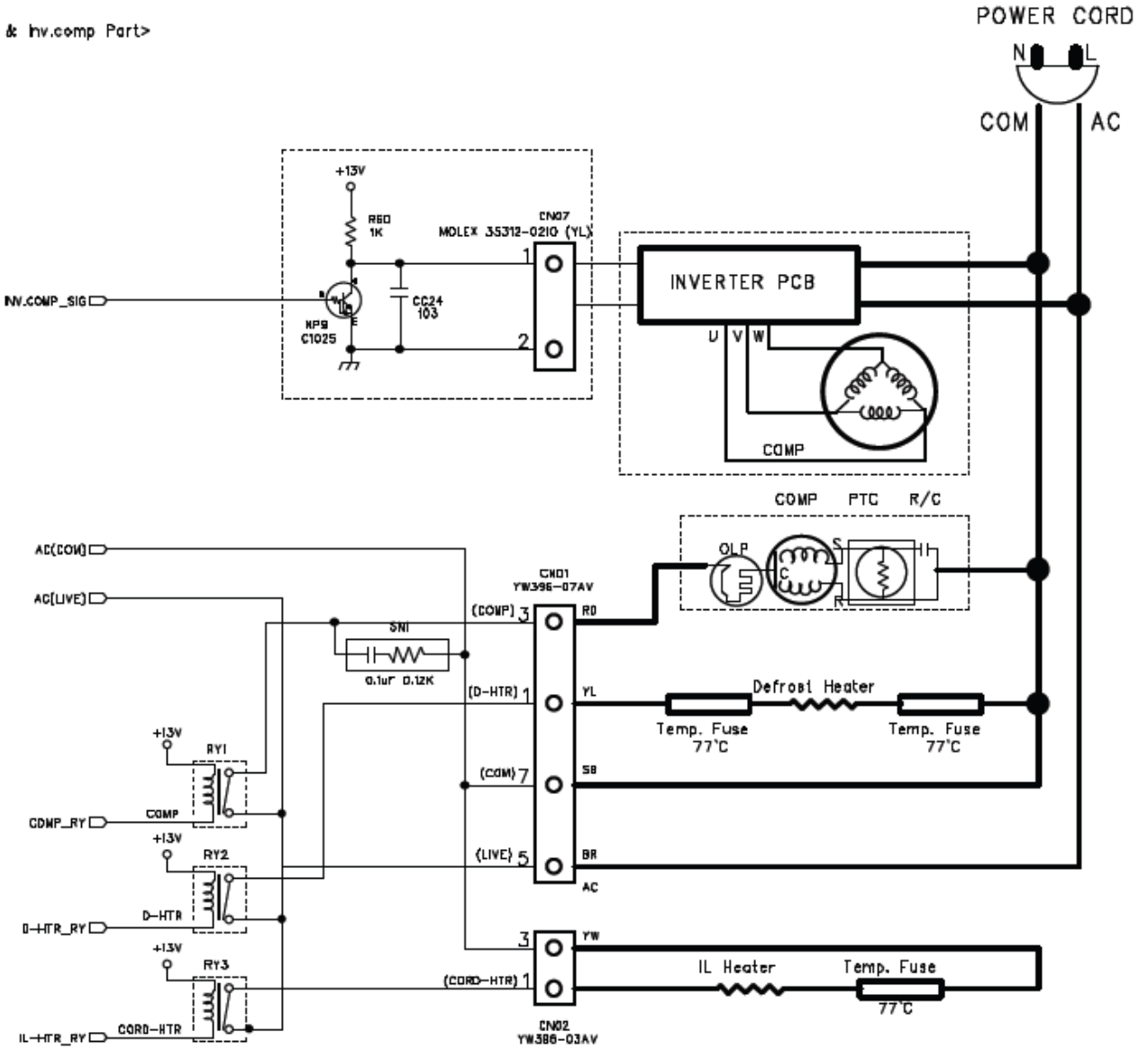

3-3. Main PCB Circuit Diagram

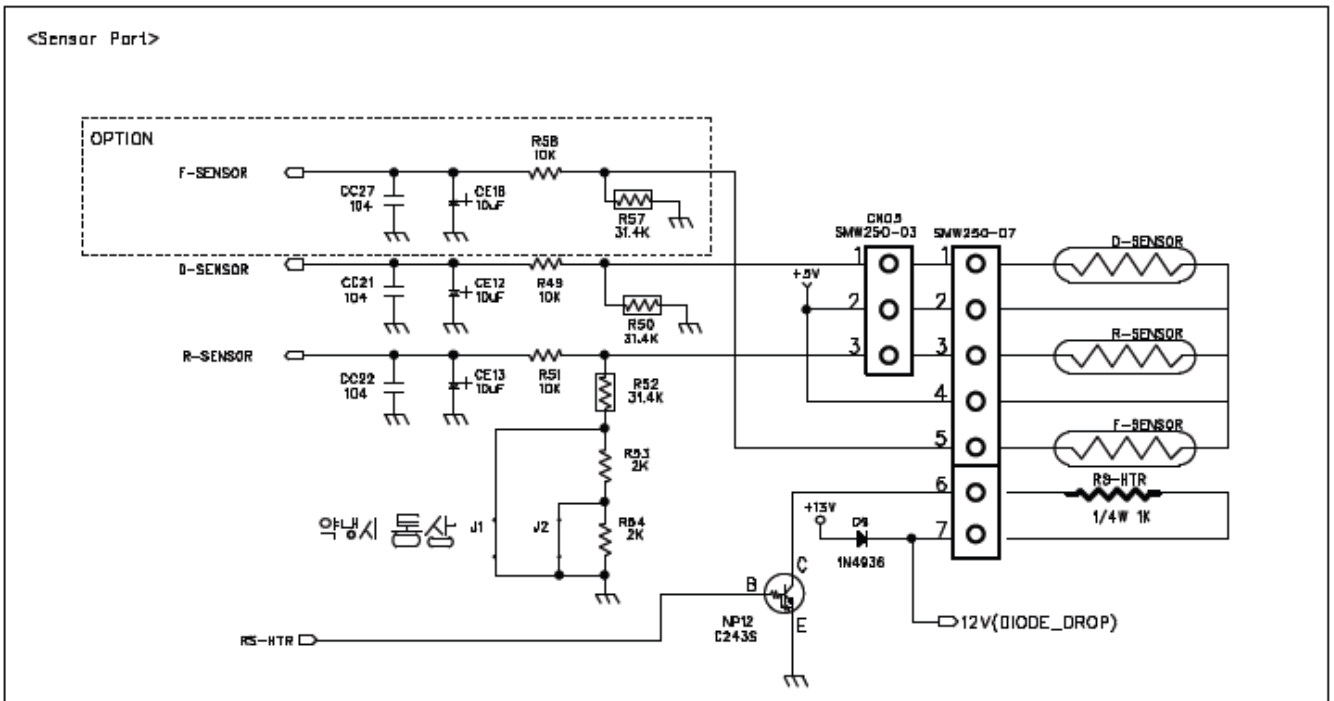
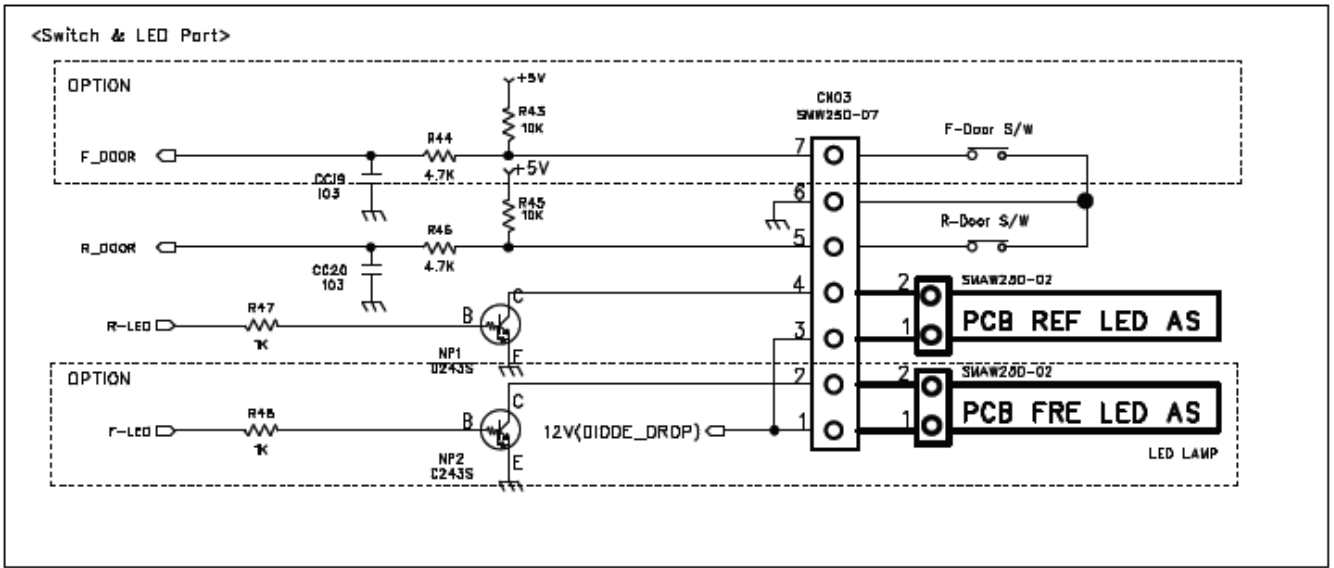

3-3. Main PCB Circuit Diagram (RCP3*** Model)

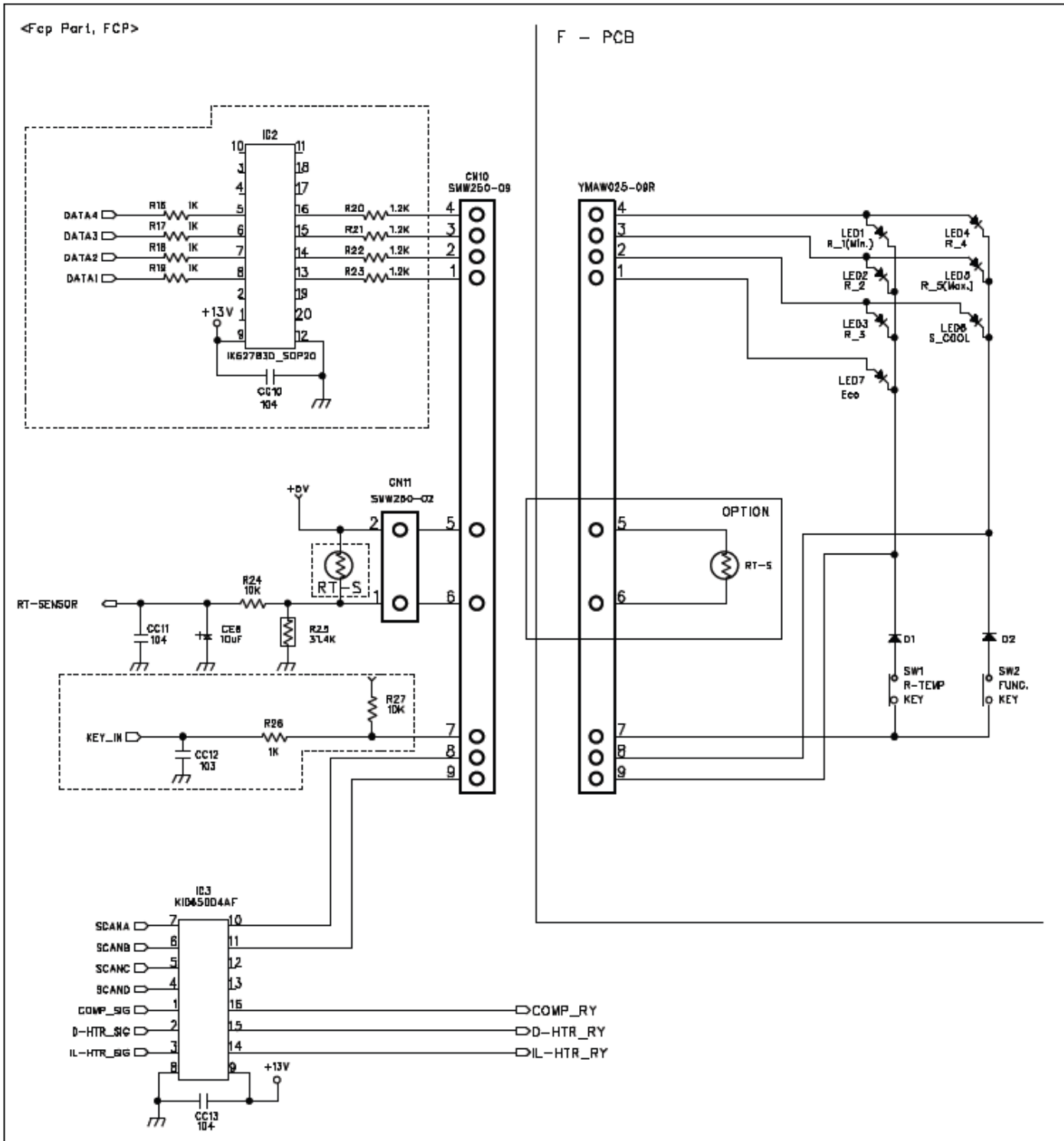

3-3. Main PCB Circuit Diagram (RCT3*** Model)

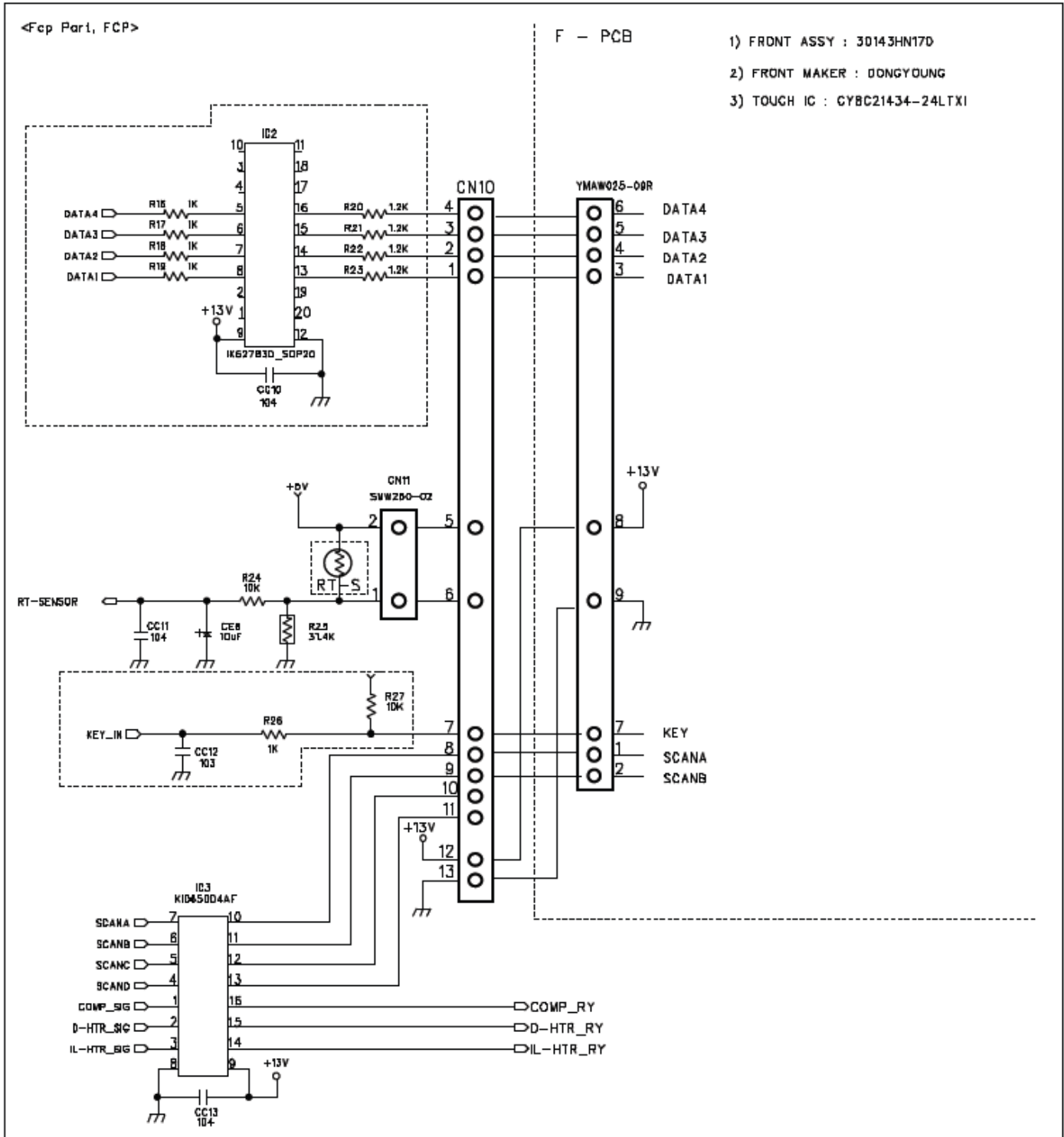

4. Product Size and Features

4-1. Exterior Size (RCP3*** Model)

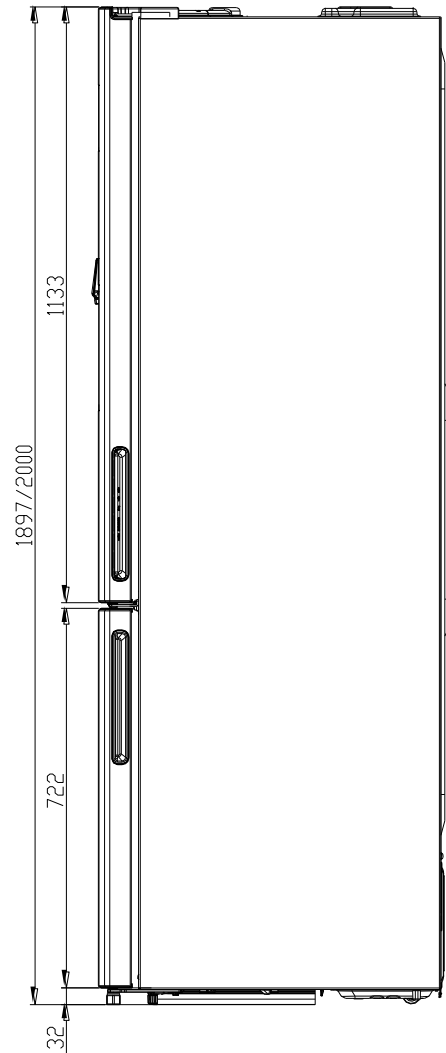
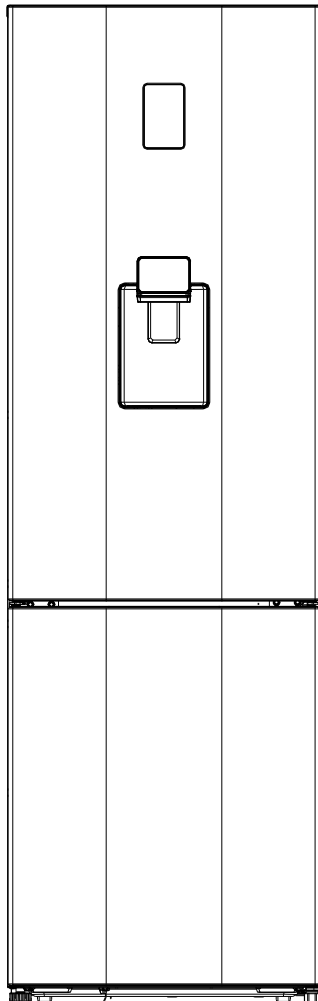
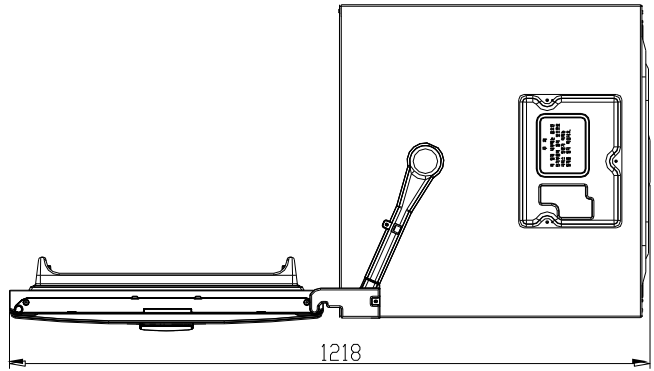
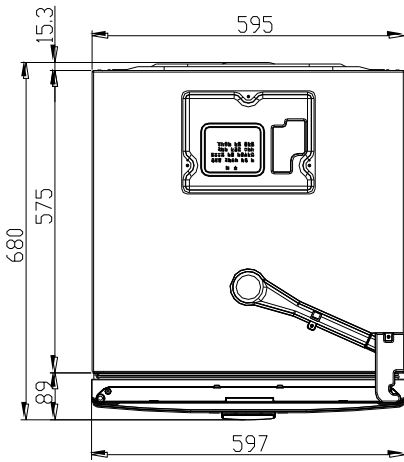

4-1. Exterior Size (RCT3*** Model)

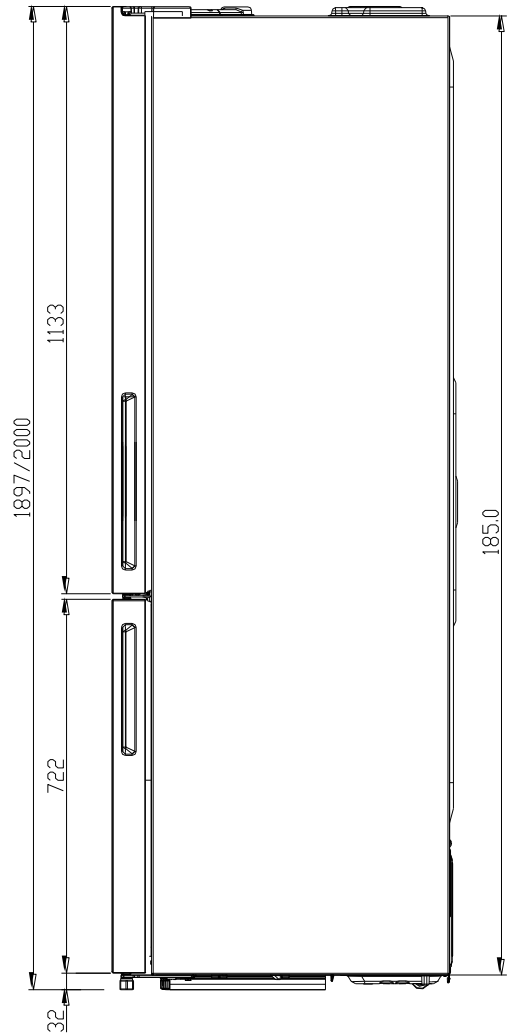
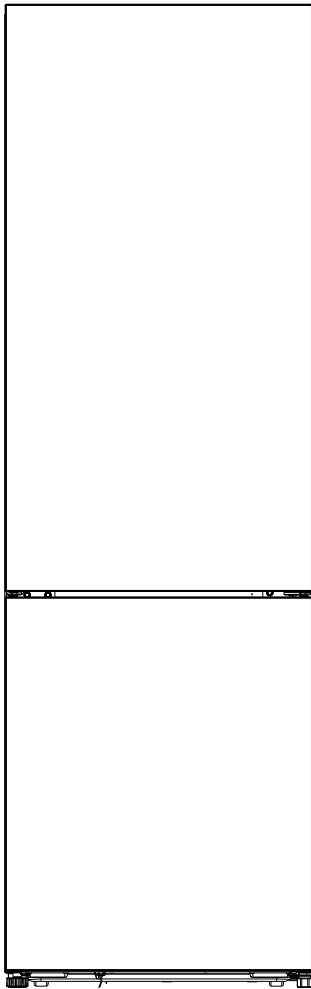
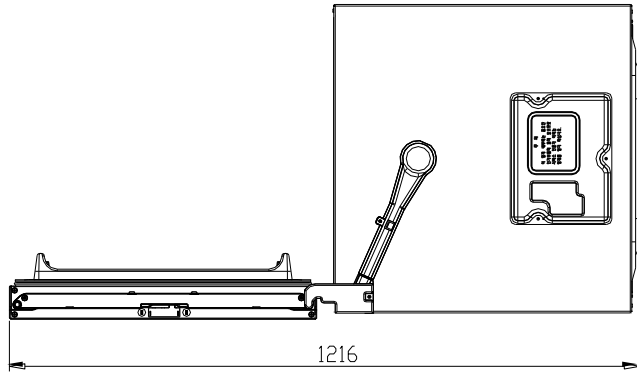
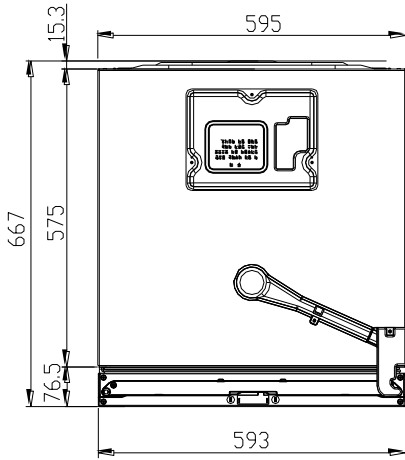

4-2. Interior Features



Refrigerator Compartment	Freezer Compartment
1. Shelves	10. Freezer Case
2. LED Lamp	
3. Multi Duct Air Flow	
4. Vegetable Plus (Option)	
5. Vegetable Case	
6. Dairy Pocket (Option)	
7. Utility Pocket	
8. Water Tank (Option)	
9. Jumbo Pocket	

4-3. Machine Room (A+ Model)

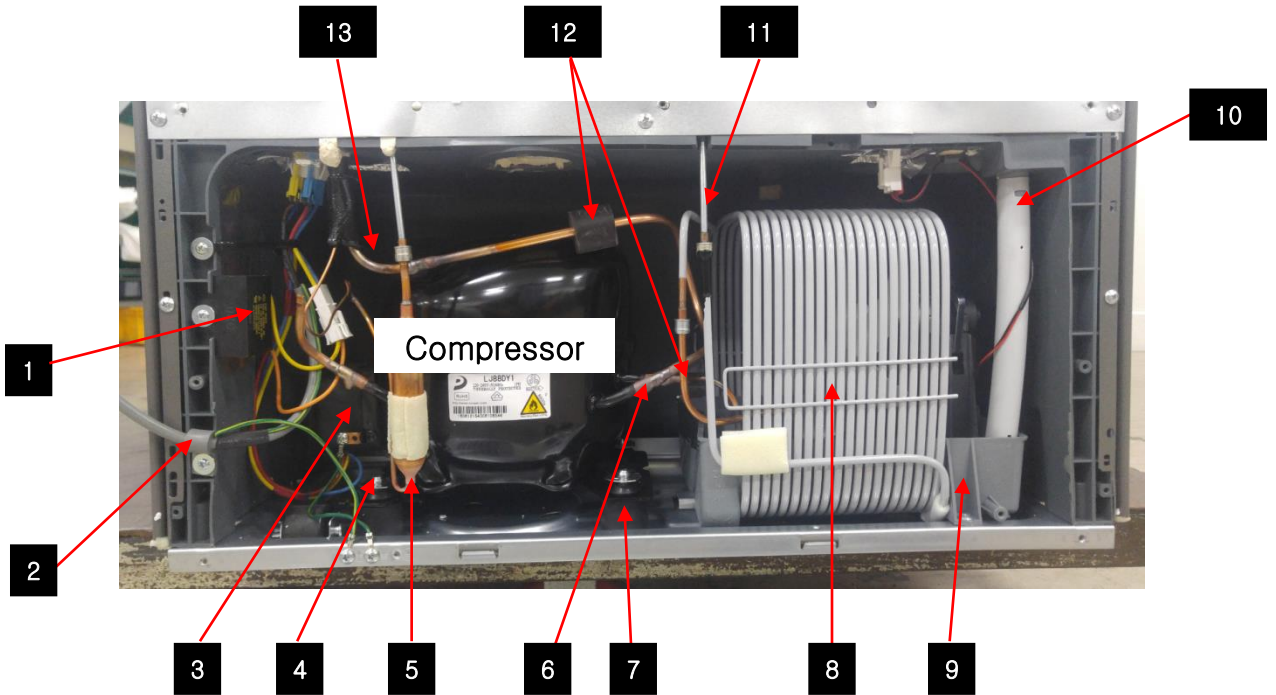

Machine Room	
1. Running Capacitor	11. Hot Pipe
2. Power Code	12. Pipe Absorber
3. Cover Relay	13. Suction Pipe
4. Special Washer	
5. Dryer	
6. Connect Pipe	
7. Absorber Comp	
8. Pipe WiCon	
9. Case Vapori	
10. Drain Hose	

4-3. Machine Room (A++ Model)

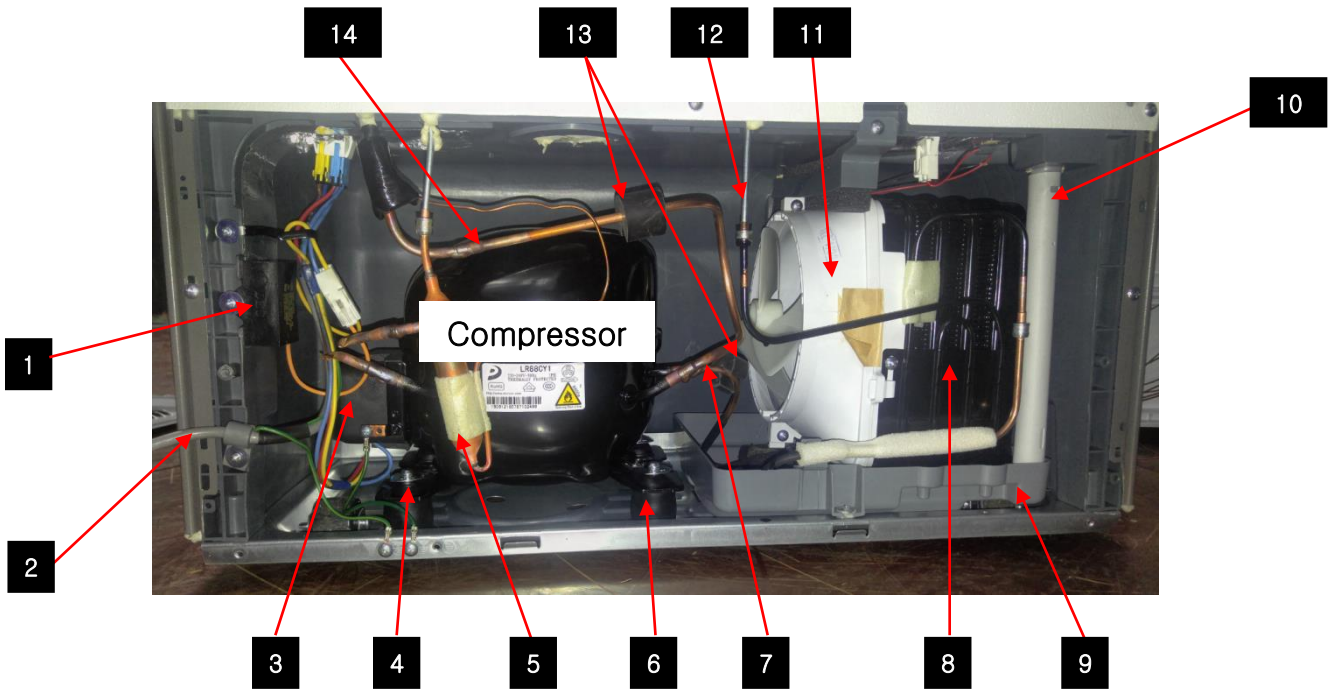

Machine Room	
1. Running Capacitor	11. Bell Mouth
2. Power Code	12. Hot Pipe
3. Cover Relay	13. Pipe Absorber
4. Special Washer	14. Suction Pipe
5. Dryer	
6. Absorber Comp	
7. Connect Pipe	
8. Pipe WiCon	
9. Case Vapor	
10. Drain Hose	

5. Cooling Cycle

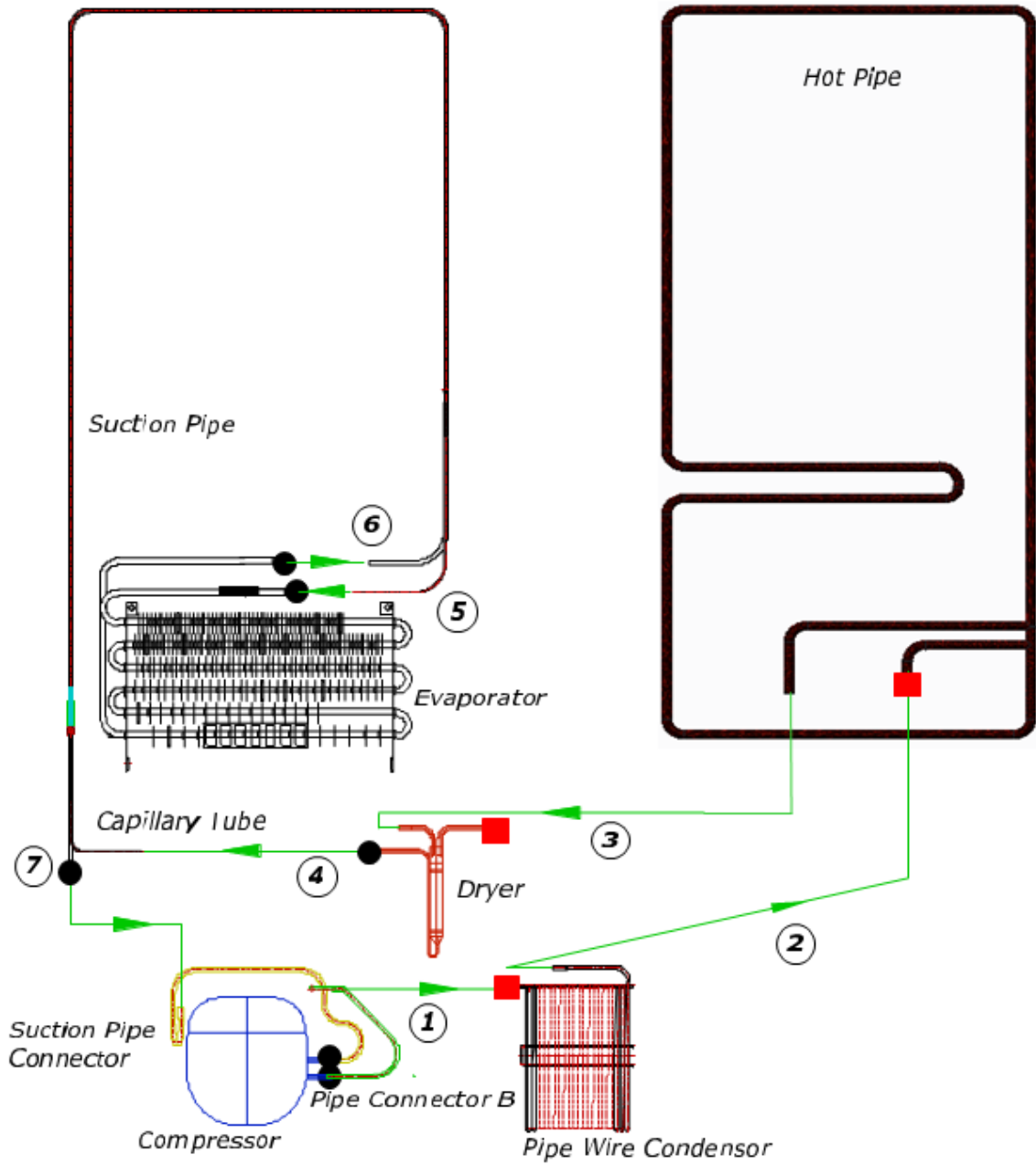

- Welding Point

●	Copper Welding (Ag 5%)	6 Point
■	Silver Welding (Ag 30%)	3 Point

6. Product Control Information

6-1. Control Panel

6-2. Freezer Control

6-3. Refrigerator Control

6-4. Special Mode Control

6-5. Comp Control

6-6. Defrost Control

6-7. Buzzer Control

6-8. Door Switch Control

6-9. Lamp Control

6-10. RS-Heater Control

6-11. Function Switch Control (Main PCB Location)

6-12. Mode Control

6-13. Control of R-sensor OFF Point

6-14. Error Code

6-15. Constraint

6-1. Control Panel

A. Panel graphic

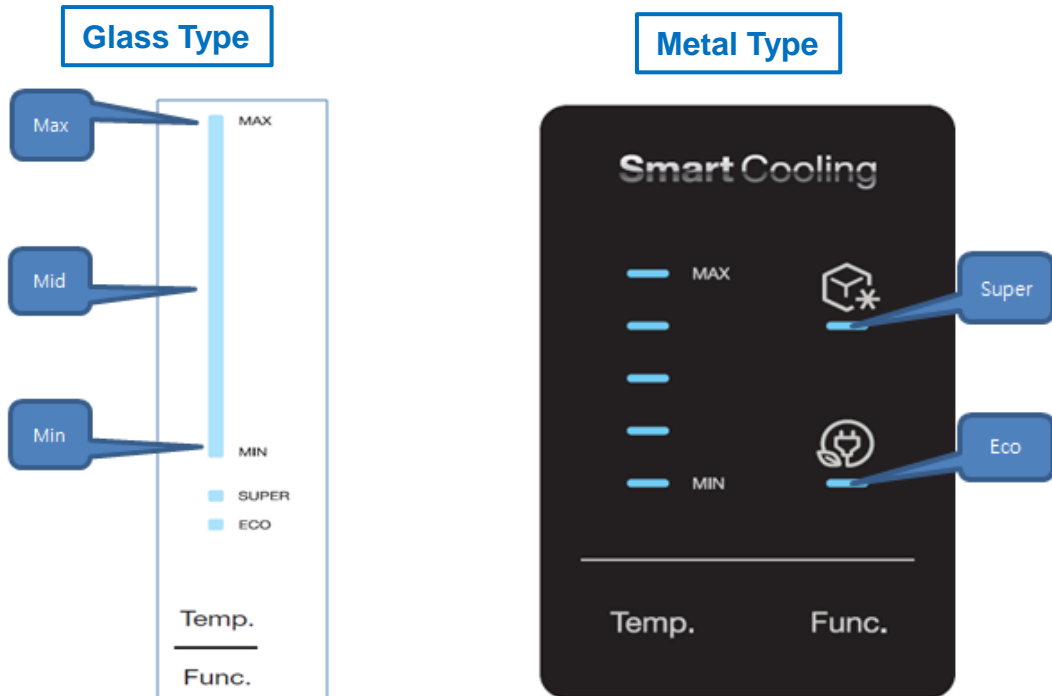

B. How to use Panel

1. Temp Key : it controls temperature of refrigerator by step.

① Default : "3step"

② How to set temperature : Push "Temp." key

③ Temperature setting sequence : 1step → 2step → 3step → 4step → 5step
 (Min) (Mid) (Max)

2. Function Key : It controls special Mode of refrigerator.

① Default : Mode Off

② How to change Mode : Push "Func." key

③ Mode change sequence : Mode Off -> Super Mode -> Eco Mode (repeat)

6-1. Control Panel

C. Display

1. Operation

- ① At normal state, display led is on by 100% brightness.
- ② When it passes 1 minutes without key operation or door operation, all led is off.
- ③ When there is operation for key or door at LED off condition, led display is back to the normal state.

2. Each MODE Display

1) Normal Mode Display

① Dial Display

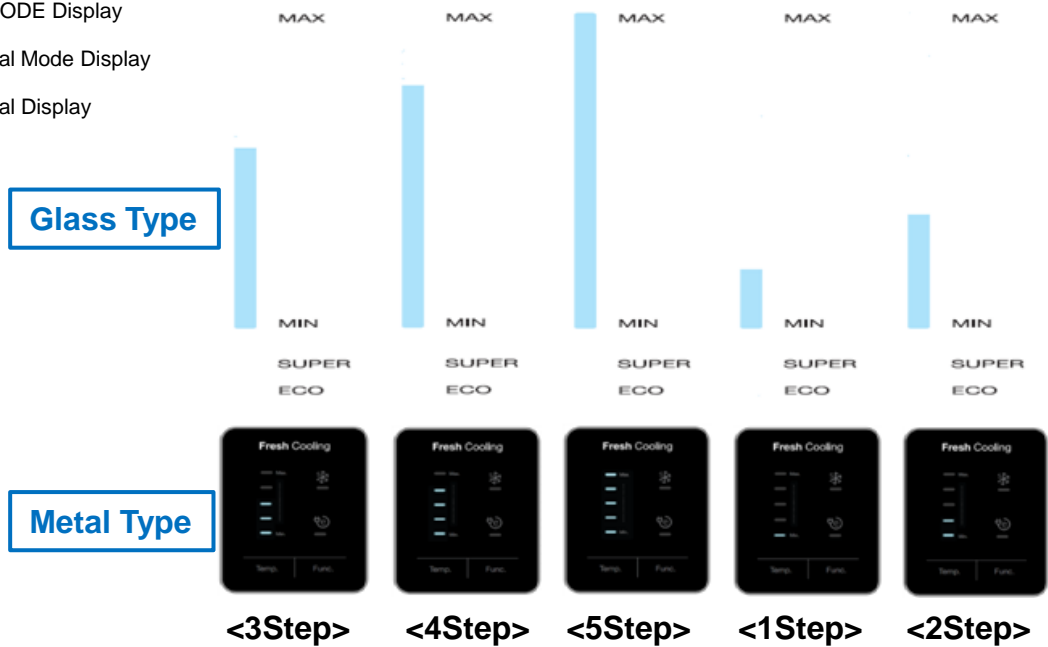

② Special Mode Display



6-2. Freezer Control

* The refrigerator is R-Control system. Freezer temperature is controlled by mechanical.

6-3. Refrigerator Control

Input	Output
- Front PCB "Temp" Key	- Refrigerator temperature

A. Dial Default Setting

- "3step"

B. Refrigerator temperature setting (at 25°C)

Model	Temperature Adjust	1step	2step	3step	4step	5step	Super
		Min		Mid		Max	Max
Glass/Metal	On Point (°C)	6.9	4.6	3.4	1.3	0.2	0.2
	Off Point (°C)	3.3	1.2	0.1	-1.9	-3.0	-3.0

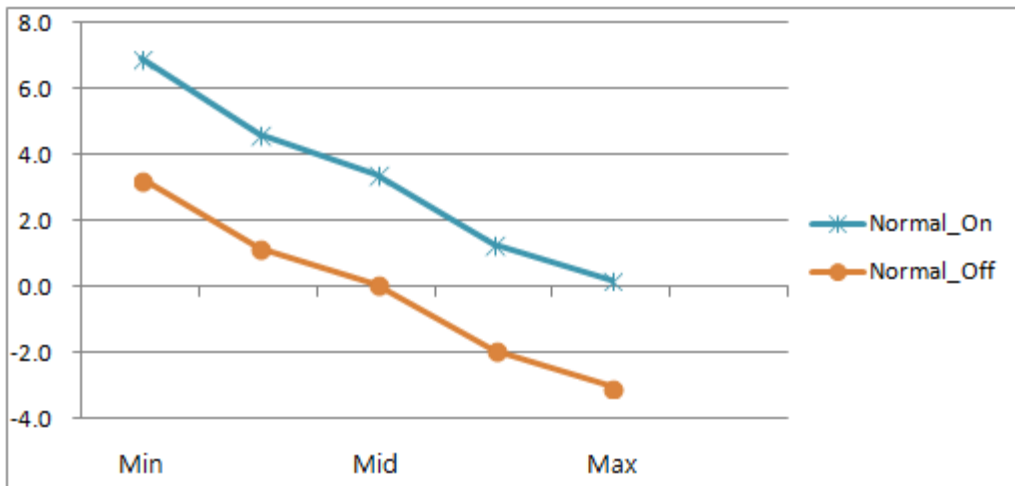

6-4. Special Mode Control

Input	Output
- "Func." Key	- Super Mode - Eco Mode

A. Special Mode

- 1) Super Mode : For quickly cooling the fridge
- 2) Eco Mode : For saving the power

B. Special Mode Operation

- 1) Super Mode

Operation time	40 minutes
COMP	Continuously On / On, Off control

- 2) Eco Mode

Operation time	Unlimited
COMP	On, Off control

C. Special Mode Release

- 1) Super Mode

- after 40 minutes .

- 2) Eco Mode

- Unlimited

- If open the door within 30 minutes, the Eco Mode is released

6-5. Comp Control

Input	Output
<ul style="list-style-type: none"> - R-Sensor - Short Circuit / Defrost Mode - Elapsed time after comp off 	<ul style="list-style-type: none"> - Comp On/Off Operation

A. General Control

1) if Defrost Mode

Precool	Comp On
Heater On	Comp Off
Pause	Comp Off
Fan Delay	Comp On

* compressor details operation sees chapter "Defrost Control".

2) if Normal Mode

① R-Sensor Error

- Compressor is controlled of the time by RT-Sensor's range.

② No R-Sensor Error

- Compressor is controlled of the setting On/Off point (reference 'Refrigerator Control')

- R-Sensor \leq Comp Off point -> Comp Off

- R-Sensor $>$ Comp On point -> Comp On

B. Prevention of Compressor Restart

- Compressor doesn't work within 6 minutes after Compressor turns off. (This is to protect comp)

ex) Compressor doesn't work after COMP turns off even though R-sensor is on condition

6-6. Defrost Control

Input	Output
- RT / D-Sensor - Comp operation time / Real Time - Comp operation rate / Door Open Time	- Defrost Heater On/Off Operation

A. Initial Defrost

CONTENTS	EXPLANATION	
Inrush conditions	If the temperature at the D-sensor is under 3.5°C, Defrost Mode starts. When D-Sensor Error is happened, the initial defrost function isn't performed .	
Each stage Release conditions	PreCool	- Exception
	Heater On	① D-Sensor > 10 °C ② after 60 minutes
	Pause	- after 10 minutes
	Fan Delay	- after 1 minute
Mode release	Auto closed after performing functions	

6-6. Defrost Control

B. Normal Defrost Mode

CONTENTS	EXPLANATION	
Inrush conditions	① When total operation time of compressor becomes: 6, 8, 10, 12 hours. ◆ Defrost conditions i . Any Error happens - R1, D1, RT, dr, F3, C1 Error ii . running rate of COMP (per 2hrs of total operation time) is more than 90%. iii. R door open time is over 2 minutes.	
	② Even if the above condition “Defrost conditions” is not satisfied, i . Defrost mode starts immediately when total operation time of COMP is 14hrs. ii . defrost mode starts immediately as long as total time (COMP on time + COMP off time) is 72 hrs.	
Each stage Release conditions	PreCool	① R-Sensor < Comp Off Point - 3.0℃ ② after 25 minutes
	Heater On	case 1) D-Sensor Error - after 30 minutes case 2) RT-Mode is “Normal-B” & No open the door & running rate of comp is less than 80% - D-Sensor > 8℃ case 3) if Comp Operating time is 6hours and the next Defrost ① D-Sensor > 13℃ ② after 70 minutes case 4) Else ① D-Sensor > 10℃ ② after 60 minutes
	Pause	case 1) if Comp Operating time is 6hours and the next Defrost - after 20 minutes case 2) Else - after 10 minutes
	Fan Delay	- after 1 minute
Mode release	Auto closed after performing functions	

6-6. Defrost Control

C. Low Temp. Defrost Mode

CONTENTS	EXPLANATION	
Inrush conditions	When RT Mode is Low-A,B, "Low Temp. defrost mode" starts immediately as long as total time (COMP on + off time) is 24 hrs. ◆ Mode Maintain conditions i . RT Mode must maintain Low-A,B	
Each stage Release conditions	PreCool	① R-Sensor < Comp Off Point - 3.0℃ ② after 25 minutes
	Heater On	case 1) D-Sensor Error - after 30 minutes case 2) RT-Mode is "Normal-A" & No open the door - D-Sensor > 8℃ case 3) Else ① D-Sensor > 10℃ ② after 85 minutes
	Pause	- after 10 minutes
	Fan Delay	- after 1 minute
Mode release	When RT Mode isn't low A, B, "Low Temp. defrost mode" is turned off immediately. At Low Temp. Defrost Mode, normal defrost mode is performed by satisfying the normal conditions.	

D. High Temp. Defrost Mode

CONTENTS	EXPLANATION	
Inrush conditions	When RT Mode is High-A,B, Defrost mode starts immediately when total operation time of COMP is 24hrs. ◆ Mode Maintain conditions i . RT Mode must maintain High-A,B ii . The door maintains closing. iii . No happened the Error	
Each stage Release conditions	PreCool	① R-Sensor < Comp Off Point - 3.0℃ ② after 25 minutes
	Heater On	① D-Sensor > 10℃ ② after 60 minutes
	Pause	- after 10 minutes
	Fan Delay	- after 1 minute
Mode release	When the condition doesn't maintain, "High Temp. defrost mode" is turned off immediately. If "High Temp. defrost mode" is released, normal defrost mode is performed.	

6-6. Defrost Control

* Defrost Flow

* General Defrost Flow

Defrost initial setting -> Precool -> Heater On -> Pause -> Fan Delay -> Defrost end setting

I . Defrost initial setting

- Each check conditions are initialization.

II . Precool

- 1) Inrush conditions : after 'Defrost initial setting" completion.
- 2) Operation: Comp is On.

III . Heater On

- 1) Inrush conditions : after 'Precool' completion.
- 2) Operation : Defrost Heater On.

IV . Pause

- 1) Inrush conditions : after 'Heater On' completion
- 2) Operation : Comp, Defrost Heater Off

V . Fan Delay

- 1) Inrush conditions : after 'Pause' completion.
- 2) Operation : Comp, C-Fan On

VI . Defrost end setting

- Each check conditions are initialization.

CONTENTS		Precool	HTR On	Pause	Fan Delay
Each stage Release conditions		Refer "Defrost Flow"			
Parts.	Comp, C Fan	On	Off	Off	On
	F-Fan	On	Off	Off	Off
	Defrost-HTR	Off	On	Off	Off

6-7. Buzzer Control

Input	Output
<ul style="list-style-type: none"> - Front key - Open the door more than 3 minute 	<ul style="list-style-type: none"> - Operate buzzer sound.

A. At power on

- After 2 seconds power's on, the buzzer rings.

B. Front Key

- Whenever "PCB Control Panel" button's pushed, the buzzer rings.

C. Test mode entry

- Operate mode changing sound
 - * As Forced Defrost Mode
 - * Demo Mode
 - * Jig Mode
 - * Fine Adjustment Mode

D. Door Open Alarm

- When door opens for 3 minutes, the buzzer rings every 1 minute for 5 minutes.

6-8. Door Switch Control

Input	Output
- High / Low Signal	- Door Open / Close State

A. R Door Switch

1) Door Open

- Door Open -> Door Switch On -> Micom Low (0V) signal Input.

2) Door Close

- Door Close -> Door Switch Off -> Micom High (5V) signal Input.

6-9. Lamp Control

Input	Output
- Door Open / Close State - Lamp On Elapsed time	- Lamp On / Off Operation

A. R Lamp

1) Door Switch Error

- R Lamp is always off.

2) No Door Switch Error

① Door Open -> Lamp On, After 10 minutes, Lamp is forcibly off.

② Door Close -> Lamp Off.

6-10. RS-Heater Control

Input	Output
- RT-Mode	- RS-Heater On / Off Operation

A. RS-Heater Operation

1) Initial Operation (Operation Test)

- After power's on, RS-Heater On/Off operation 5 times for 12 seconds.

2) RS-Heater Control

① Control Start

- From the time the comp off the initial one-time controls R_S-HTR.

② Operation

D-HTR On	D-HTR Off		
RS-HTR On	Comp Off		Comp On
	RT-Mode is "Low-A/B" & No RT Error	Else	RS-HTR Off
	After 6 min, RS-HTR On	RS-HTR Off	

6-11. Function Switch Control (Main PCB Location)

Input	Output
- Test Switch - Time Switch	- Short Circuit / Power Saving / As Forced Defrost Mode selection. - Time Pass control

A. Test Switch

- Using Test Switch (Part No. SW2) in the Main PCB, short-circuit mode, the Power Saving mode, As forced defrost mode can be entered.

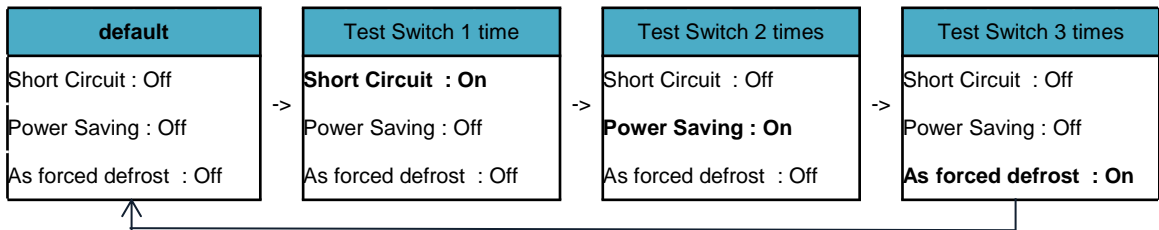

B. Time Switch

- Using Test Switch (Part No. SW1) in the Main PCB, it can send forcedly the time.

① Short Click the Time Switch (within 1 second)

- 1 min : Click Time Switch one time on MAIN PCB.

② Push the Time Switch (more than 1 second)

- 30 min : If you press FAST KEY continuously, you can reduce 30 minutes on each 2.5 seconds with buzzer.

6-12. Mode Control

**The mode can be entered within 2 hours.
After 2 hours, The mode enterable environment is activated by pushing "TEMP + "FUNC" Key for 10 seconds.**

A. As Forced Defrost Mode

1) How to enter

① How to enter through Key Operation

- by press "TEMP" button for continuously and "FUNC" button 5 times.

② How to enter through Main PCB Test Switch

- See part of the "Test Switch" in "Function Switch Control" Chapter.

2) Operation

- Process: same as General Defrost Mode except "PRE-COOL"

- Heater is on Initial 60 seconds even though the temp.

(for TEST)

CONTENTS		HTR On	Pause	Fan Delay
Limited Time		60 minutes	10 minutes	1 minutes
Each stage Release conditions		1. Limited Time 2. D-S > 10°C	Limited Time	Limited Time
Parts.	Comp	Off	Off	On
	Defrost-HTR	On	Off	Off
	F- Fan	Off	Off	Off

3) Mode release : Auto closed after performing functions.

B. Short Circuit Test Mode

1) How to enter : See part of the "Test Switch" in "Function Switch Control" Chapter.

(It is available to restart the test and it'll be take 30 hours.)

2) Operation

- COMP & FAN will be on independent of the operating condition.

- There is no defrost mode on this test.

3) Mode release : after the limit test time 30 hours passes.

6-12. Mode Control

C. Error Display Mode

1) How to enter : by pressing "FUNC" button for continuously and "TEMP" button 5 times.

2) Operation

- To confirm error happens or not, check Display LED

- When No Error, Only Eco LED blink.

① R Sensor Open : Fridge Temperature Bar "1"step LED On

R Sensor Short : Fridge Temperature Bar "1"step LED Twinkle

② RT Sensor Open : Fridge Temperature Bar "2"step LED On

RT Sensor Short : Fridge Temperature Bar "2"step Twinkle

③ D Sensor Open : Fridge Temperature Bar "3"step On

D Sensor Short : Fridge Temperature Bar "3"step Led Twinkle

④ R Door Error : Fridge Temperature Bar "5"step Led On

⑤ Cycle Error : Super Led On

⑥ Return Defrost Error : Super Led Twinkle

3) Mode release : Push "FUNC" 1 time.

6-12. Mode Control



































































D. Fine Adjustment Mode



1) How to enter : by pressing "TEMP" buttons for 10 seconds.

2) Operation

- When enter the mode, Only Super LED blink

- On / Off point is varied by fine adjustment value.

DISPLAY	Eco	Fridge Temperature Bar					fine adjustment value
		"1"step	"2"step	"3"step	"4"step	"5"step	
LED ON/OFF							-5
							-4
							-3
							-2
							-1
							0
							1
							2
							3
							4
							5

 : LED On
 : LED OFF

3) Mode release : When it passes 5seconds without key operation, auto closed the mode.

E. Demo Mode

1) How to enter : by pressing "FUNC" buttons for 10 seconds.

2) Operation

- All electronic compartments are off except "Display Panel".

- "1"step -> "2"step -> "3"step -> "4"step -> "5"step -> Super -> Eco -> All Led Off

- When "DEMO" mode works, led lamps will be on as next steps.

3) Mode release : by pressing "FUNC" buttons for 10 seconds

6-13. Control of R-sensor OFF Point

Input	Output
- J1, J2 On Main PCB	- Control Resistance of R sensor OFF Point

A. LOW COOLING OPTION

- (1) Adjust R-Sensor off point (Max 3.0deg down)
- (2) the following actions are recommended for service.
 - ① Resistance (R52) : Default resistance (31.4Kohms)
 - ② Resistance (R53) : Cut the "J1" off to reduce basic resistance by 1.5°C. (2KΩ up)
 - ③ Resistance (R54) : Cut the "J2" off additionally to reduce basic resistance by 1.5°C. (total 4KΩ up)

ex) $R52 = \text{R-SENSOR OFF point}$

$$R52 + R53 = \text{R-SENSOR OFF point} - 1.5^{\circ}\text{C}$$

$$R52 + R53 + R54 = \text{R-SENSOR OFF point} - 3^{\circ}\text{C}$$

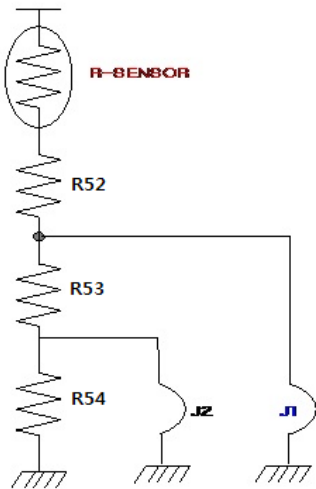

6-14. Error Code

A. R-Sensor Error

- 1) Error Code : R1
- 2) Condition :
 - ① R-Sensor Open : It happens when R-Sensor is sensing less than -45°C
 - ② R-Sensor Short : It happens when R-Sensor is sensing more than 50°C
- 3) release : When R-Sensor is sensing from -45 to 50°C .

B. RT-Sensor Error

- 1) Error Code : Rt
- 2) Condition :
 - ① RT-Sensor Open : It happens when RT-Sensor is sensing less than -45°C
 - ② RT-Sensor Short : It happens when RT-Sensor is sensing more than 50°C
- 3) release : When RT-Sensor is sensing from -45 to 50°C .

C. D-Sensor Error

- 1) Error Code : D1
- 2) Condition :
 - ① D-Sensor Open : It happens when D-Sensor is sensing less than -45°C
 - ② D-Sensor Short : It happens when D-Sensor is sensing more than 50°C
- 3) release : When D-Sensor is sensing from -45 to 50°C

D. R-Door Error

- 1) Error Code : dr
- 2) Condition : It happens when the system senses R-Door opens more than 1 hour
- 3) release : If R-Door switch (close) is sensed, the error is terminated automatically

E. Cycle Error

- 1) Error Code : C1
- 2) Condition : When D-Sensor is more than -5°C , Comp operates over 3 hours
- 3) release : When Comp is off, D-Sensor is less than -5°C .

* When D-Sensor is normal operation, "C1" Error can be checked.

F. Return Defrost Error

- 1) Error Code : F3
- 2) Condition : Return to next limit defrost time.
- 3) release : Completion of defrost returned by D-Sensor.

* When D-Sensor is normal operation, "F3" Error can be checked.

6-15. Constraint

A. H/W Constraint

- According to the local environment and Micom Spec, hardware function can be constrained.





B. S/W Constraint

- Depending on the amount of memory and CPU performance may be different from the S / W performance results
- When operating with other and different applications, it may be deteriorated.



7. Disassembly / Assembly Guide of Each Part

(Assembly is the reverse order of disassembly)



7-1. Front FCP (RCT3*** Model)

No	Procedure	No	Procedure
1	 <p>REF Door Cap</p> <p>Unscrew 2 points with (+) driver.</p>	4	 <p>Put Fixture FCP AS (Fixture FCP & FCP) out.</p>
2	 <p>Remove top cover cap from top cap.</p>		5
3	 <p>With driver, Lift up the Fixture FCP.</p>		



7-2. Front FCP (RCP3*** Model)

No	Procedure	No	Procedure
1	 <p data-bbox="137 644 596 727"><i>Attach OPP tape on side of 'Front PCB' to prevent scratch.</i></p>	3	 <p data-bbox="786 644 1193 675"><i>Disconnect 'Front PCB' lead wire.</i></p>
2	 <p data-bbox="137 969 661 1048"><i>Disassemble 'Front PCB' with using flathead tools as next picture.</i></p>		







7-3. Door Switch

No	Procedure	No	Procedure
1	 <p>Insert a flathead tool Into a gap of door switch to pull forward.</p>	2	 <p>Disconnect the housing and change the switch for a new one.</p>



7-4. Multi Duct As (Refrigerator)

No	Procedure	No	Procedure
1	 <p>Remove screw cap with (-) driver. (2 points)</p>	3	 <p>Disconnect the Sensor wire housing.</p>
2	 <p>Unscrew 2 points with (+) driver.</p>		





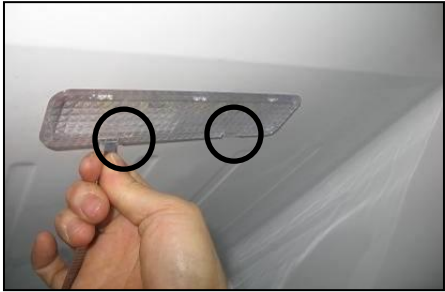

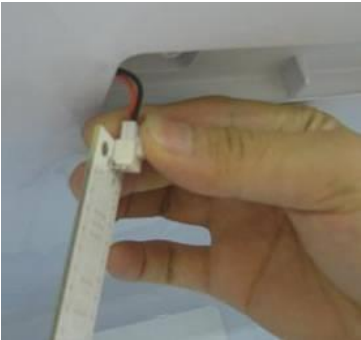





7-5. Louver F As (Freezer)

No	Procedure	No	Procedure
1	 <p data-bbox="137 685 601 747"><i>Unscrew the fixing screw to remove the Louver F As.</i></p>	4	 <p data-bbox="779 685 1315 747"><i>Remove 3 screws in order to disassemble the Louver F As.</i></p>
2	 <p data-bbox="137 1110 662 1152"><i>Remove the Louver F As pulling the top side.</i></p>	5	 <p data-bbox="779 1110 1315 1152"><i>When disassembling check the Knob position.</i></p>
3	 <p data-bbox="137 1514 558 1549"><i>Disconnect Fan motor wire housing.</i></p>	6	 <p data-bbox="779 1514 1048 1549"><i>Default position is 'Mid'</i></p>



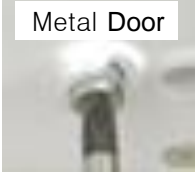



7-6. LED Lamp (Refrigerator)

No	Procedure
1	 <p data-bbox="182 675 701 754"><i>Using a flathead tool, Pull both locker and Separate a Window LED from Liner.</i></p>
2	 <p data-bbox="175 1152 568 1187"><i>Unscrew 2 points with (+) driver</i></p>
3	 <p data-bbox="175 1583 622 1618"><i>Disconnect LED PCB form housing.</i></p>

7-7. Door Reversible

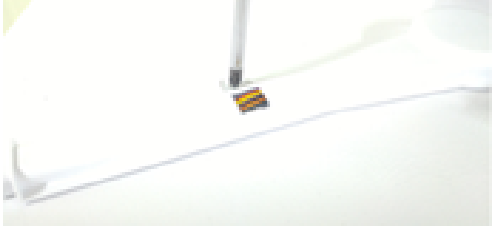
No	Procedure	No	Procedure
1	 <p>Remove top cover harness screw with (+) driver.</p>	7	 <p>Moving FCP housing from left to right side.</p>
2	 <p>Remove top cover hinge screw with (+) driver.</p>	8	 <p>Put on the harness in the door cap.</p>
3	 <p>Disconnecting FCP housing.</p>	9	 <p>Assemble top cover cap screw with (+) driver.</p>
4	 <p>Remove top hinge.</p>	10	  <p>Glass Door</p>  <p>Metal Door</p>
5	 <p>REF Door Cap</p> <p>Remove top cover cap screw with (+) driver. (2points)</p>		<p>Remove door stopper located in under cap, and Reassemble this to opposite side.</p>
6	 <p>Remove top cover cap from top cap.</p>	11	  <p>Remove middle hinge, cap bushing and stopper located in top cap of freezer door, and Reassemble these to opposite side.</p>

7-7. Door Reversible

No	Procedure	No	Procedure
12	 <p>Change the location (screw & division hinge cap)</p> <p>Change the under hinge location to the opposite.</p>	16	 <p>Assemble the separate service top left hinge.</p>
13	 <p>Reverse the under hinge and change its location to the opposite. And also change the foot adjust location to the opposite.</p>	17	 <p>Assemble top cover harness screw with (+) driver.</p>
14	 <p>Assemble the under hinge shaft to the reverse side.</p> <p>And then assemble the foot adjust by downwards.</p>	18	 <p>Connect housing. (FCP & Harness cabinet)</p>
15	 <p>Move the under hinge to the left and assemble the freezer door first and refrigerator door later.</p>	19	 <p>Assemble top hinge cover with (+) driver.</p>

8. Exploded View and SVC Parts List

8-1. Exploded View

A> CABINET

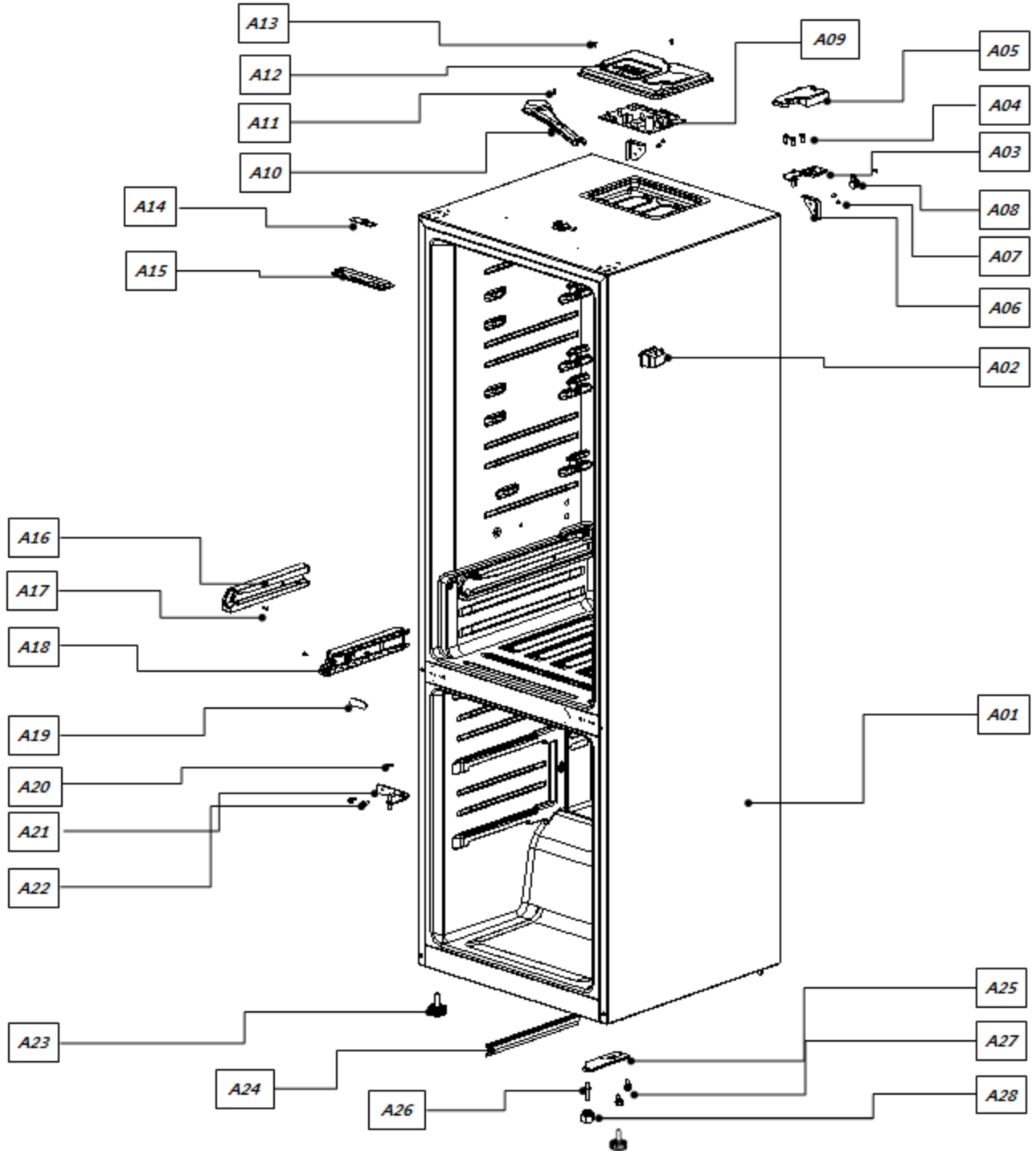

8-1. Exploded View

B> MECH ROOM

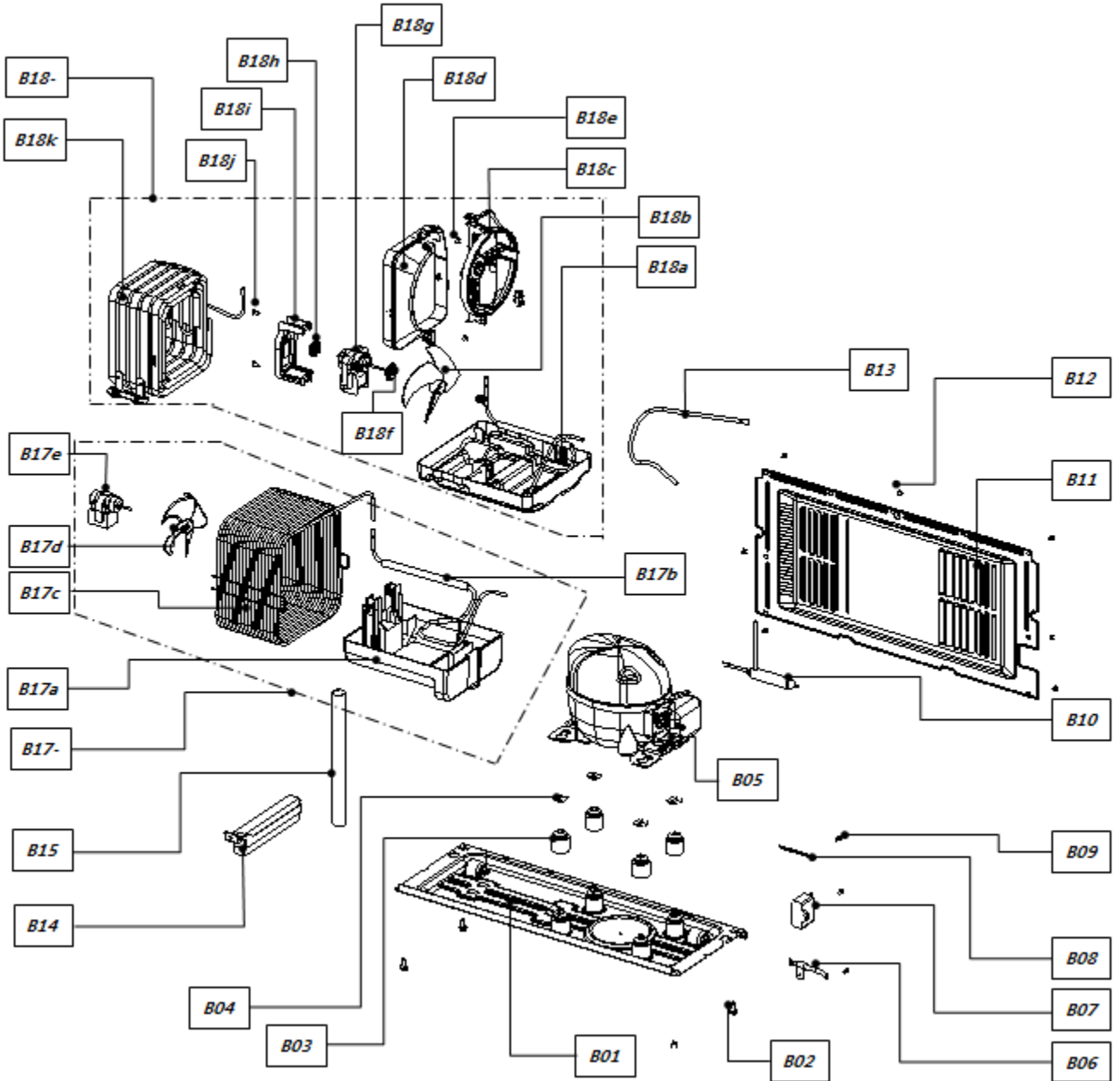

8-1. Exploded View

C> COVER M/F DUCT AS
 D> EVAPORATOR AS
 E> LOUVER F A

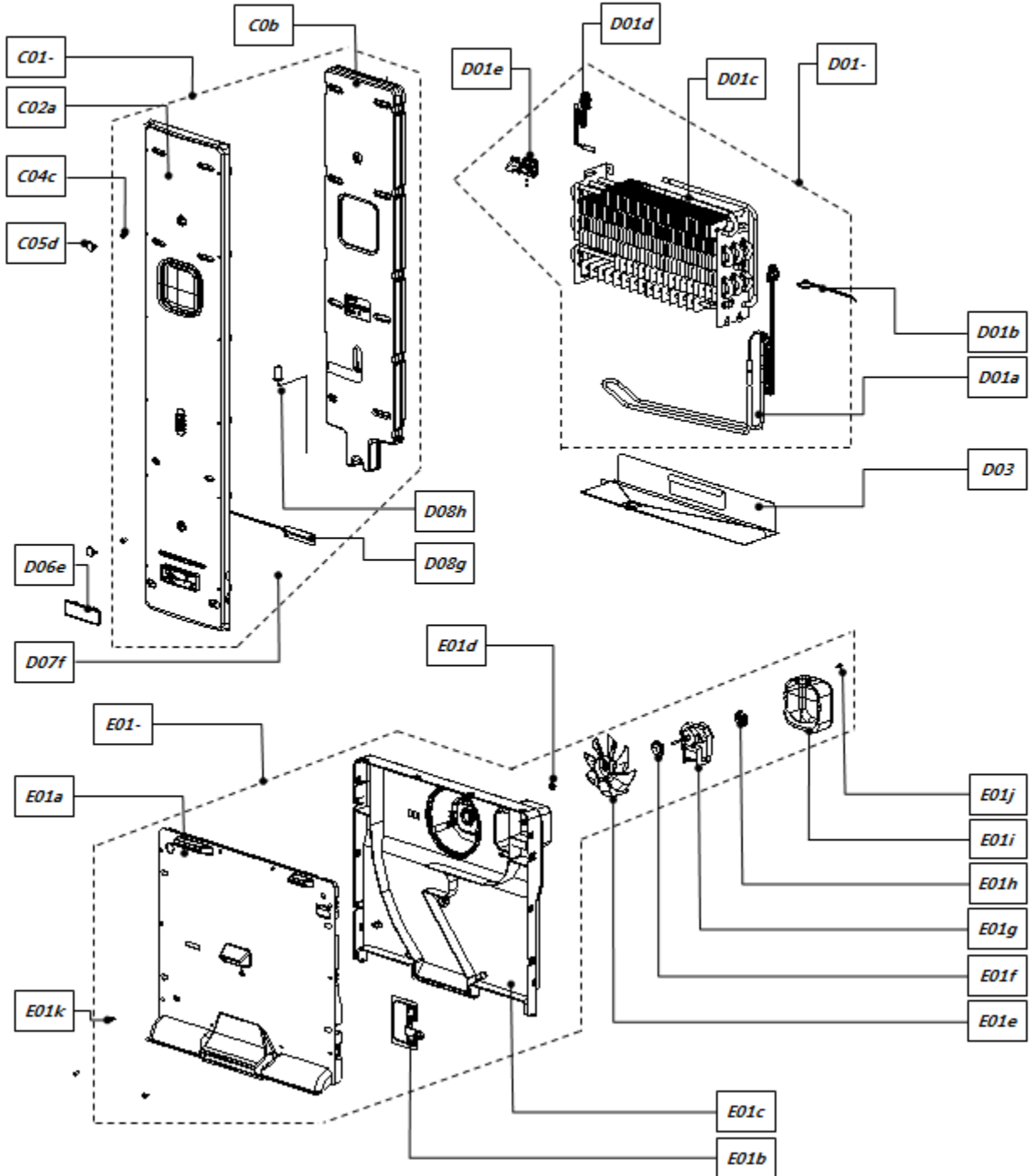

8-1. Exploded View

F> REFRIGERATOR COMPARTMENT
G> FREEZER COMPARTMENT

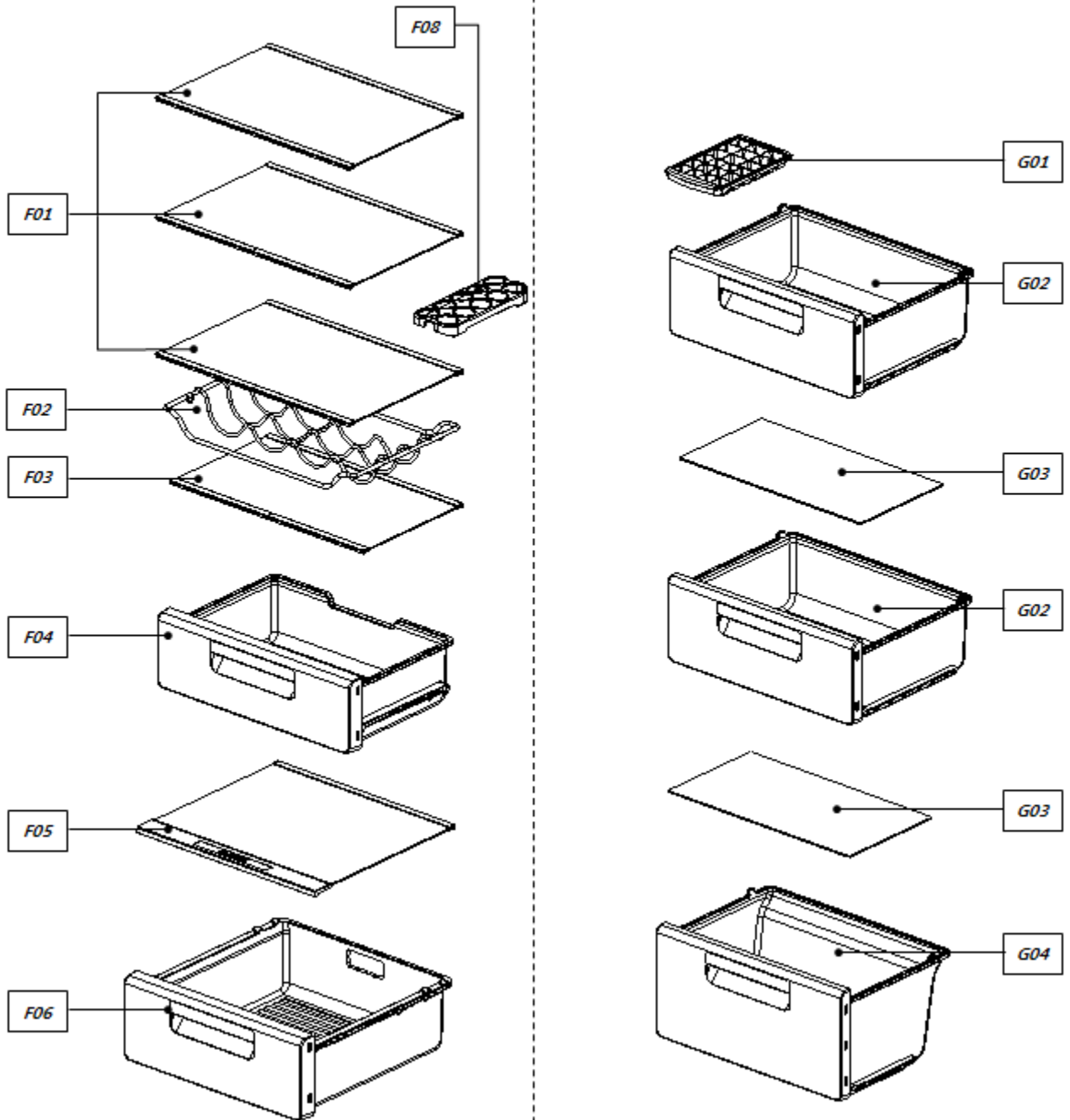

8-1. Exploded View

H> REFRIGERATOR DOOR
 I> FREEZER DOOR

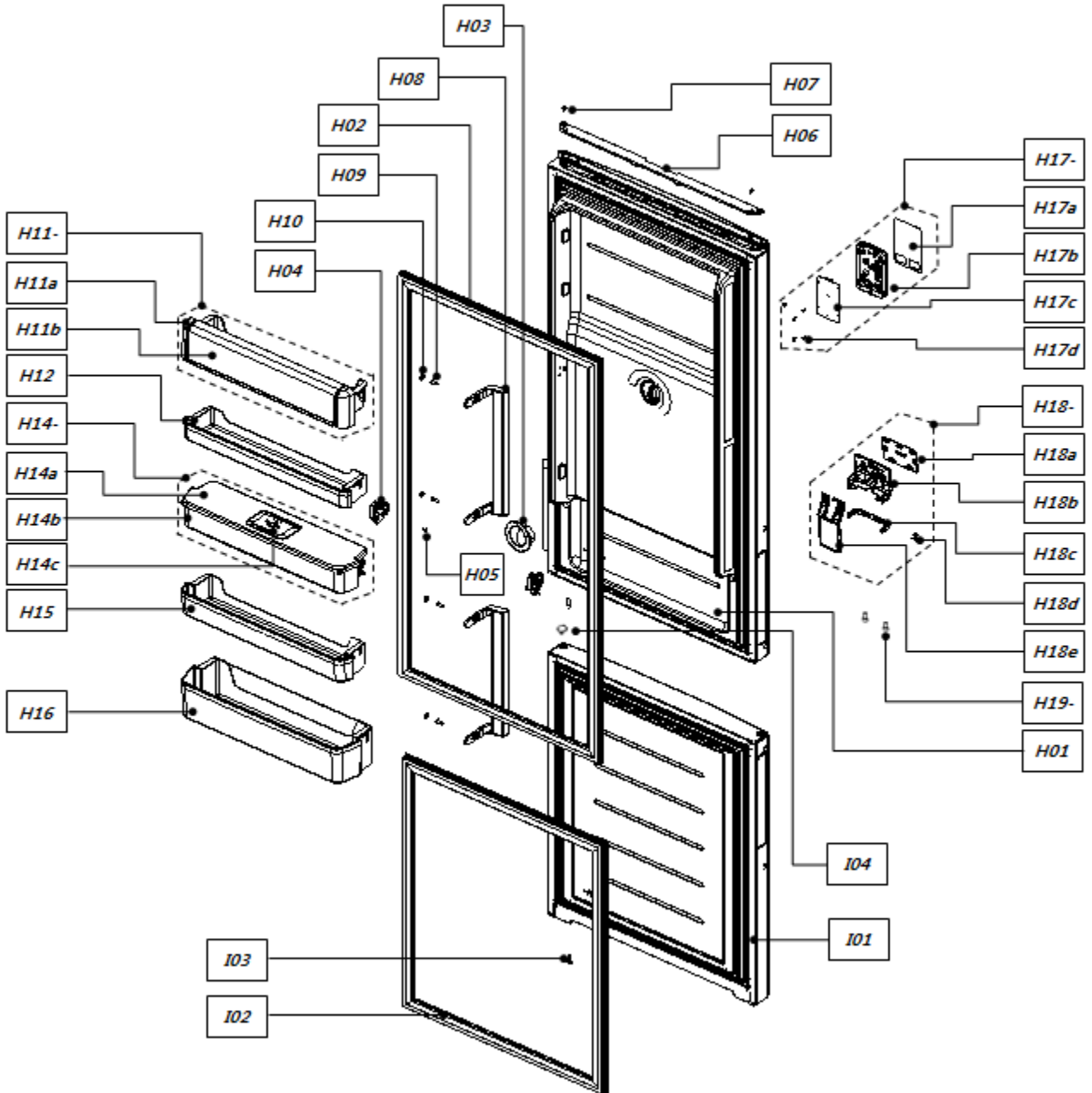

8-1. Exploded View

J> FREEZER DOOR
K> REFRIGERATOR DOOR

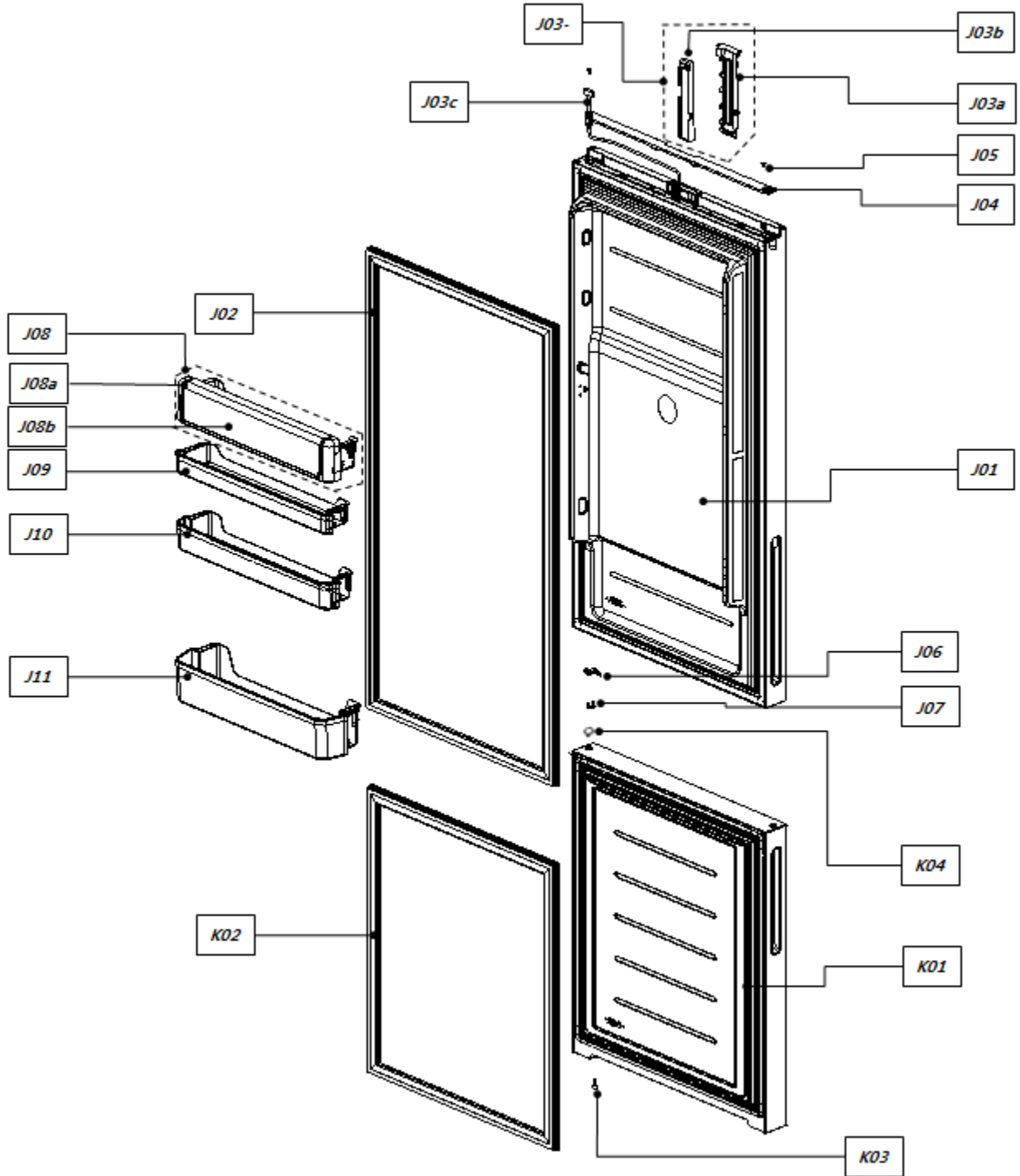

8-2. Parts List

NO	PART-CODE	PART NAME	SPEC.	Q'ty				Remark
				RCP330	RCP360	RCT330	RCT360	
A> CABINET								
A	0 1 -	30100-0217300 30100-0212400	ASSY CAB URT	RC-P330 RC-P360	1		1	
A	0 2 -	30117-0033800	SWITCH DR AS	DOOR S/W AS HC-050K4 250V2.5A	1	1	1	1
A	0 3 -	30129-0021400	HINGE T R AS	RCP346	1	1	1	1
A	0 4 -	30160-0001001	SPECIAL BOLT	6*22 SWCH22A(WH)	3	3	3	3
A	0 5 -	30114-0093400	COVER HI T R	RCP346	1	1	1	1
A	0 6 -	30109-0013400	CAP CAB COVER	PP	2	2	2	2
A	0 7 -	90007-0003700	SCREW TAPPING	T1 TRS 4*12 MFZN	4	4	4	4
A	0 8 -	30130-0000200	HODER POWER CODE	PP(NATURAL)	1	1	1	1
A	0 9 -	40301-0101800	PCB MAIN ASSY	NEO-V	1	1	1	1
A	1 0 -	30114-0091200	COVER CAB HRNS	RCP346	1	1	1	1
A	1 1 -	30160-0001001	SCREW TAPPING	6*22 SWCH22A(WH)	1	1	1	1
A	1 2 -	30114-0008102	COVER M PCB BOX AS	EMBO PCM SCRAP(BACK COATING)	1	1	1	1
A	1 3 -	30160-0001001	SCREW TAPPING	6*22 SWCH22A(WH)	3	3	3	3
A	1 4 -	40301-0081800	LAMP LED AS	LAMP LED AS 5LED,DC12V	1	1	1	1
A	1 5 -	30155-0017300	WINDOW F LAMP	GPPS	1	1	1	1
A	1 6 -	30125-0038500	GUIDE FRESH CASE *L	PP	1	1	1	1
A	1 7 -	90007-0003700	SCREW TAPPING	T1 TRS 4*12 MFZN	2	2	2	2
A	1 8 -	30125-0038600	GUIDE FRESH CASE *R	PP	1	1	1	1
A	1 9 -	30109-0007600	CAP DV M HI HOLE	ABS	1	1	1	1
A	2 0 -	30160-0006900	SPECIAL WASHER *M HI	SGCC, T1.0X1.D9.0X0.D15	1	1	1	1
A	2 1 -	30129-0022000	HINGE M AS	HINGE *M AS RCP346	1	1	1	1
A	2 2 -	30160-0001002	SPECIAL BOLT	6X15 SWCH22A(WH)	2	2	2	2
A	2 3 -	30121-0001401	M FOOT ADJ AS	PP(BLACK)	2	2	2	2
A	2 4 -	30123-0005701	GASKET CAB BASE	GASKET CAB BASE PVC	1	1	1	1
A	2 5 -	30129-0020900	HINGE *U AS	HINGE *U AS NEO V-PJT	1	1	1	1
A	2 5 a	30129-0021000	HINGE U	PQ, T5.0	1	1	1	1
A	2 5 b	30149-0006000	SHAFT U HI	S20C, OD8	1	1	1	1
A	2 5 c	30121-0003800	FOOT ADJ AS	PP+Insert RCP330,360	3	3	3	3
A	2 6 -	30160-0001001	SPECIAL BOLT *T	T 6*22 SWCH22A(WH)	1	1	1	1
B> MECH ROOM								
B	0 1 -	30103-0034700	BASE COMP AS	SBHG-A RCP330,360	1	1	1	1
B	0 2 -	30160-0001001	SPECIAL BOLT	6*22 SWCH22A(WH)	4	4	4	4
B	0 3 -	60101-0000600	ABSORBER COMP	ABSORBER COMP NBR	4	4	4	4
B	0 4 -	30160-0001300	SPECIAL WASHER COMP	SK-5 T0.8XW22XL24.5	4	4	4	4
B	0 5 -	60110-0022200	COMPRESSOR	TH1114YL JIAXIPERA R600a 220 50	1	1	1	1
B	0 5 1	60110-0022000		LJ88DY1 DONPER R600a 220 60	1	1	1	1
B	0 5 2	60110-0021900		LR88CY1 DONPER R600a 220 50	1	1	1	1
B	0 5 3	60110-0022100		LJ88XY1 DONPER R600a 127 60	1	1	1	1
B	0 6 -	60113-0006600	CORD POWER AS	GPF REF, EU(LP-33)	1	1	1	1
B	0 7 -	60164-0002304	CAPACITOR RUN SQ	450V,4UF(WIRE HOUSING,CQC)	1	1	1	1
B	0 7 1	60164-0000800		250V,12UF(WIRE HOUSING,CQC)	1	1	1	1
B	0 8 -	30112-0001501	CLAMP CORD		1	1	1	1
B	0 9 -	90007-0003700	SCREW TAPPING	T1 TRS 4*12	2	2	2	2
B	1 0 -	60168-0002000	DRYER AS	10 RCT(P)32/34/35*	1	1	1	1
B	1 1 -	30114-0098700	COVER MACH RM AS	RCP330,360	1	1	1	1
B	1 2 -	30160-0003401	SCREW TAPPING	TH1/W #8X1/2 MFZN	6	6	6	6
B	1 3 -	60144-0022600	PIPE SUC CONN RGP56	DUCT1-0 OD6*TO.5	1	1	1	1
B	1 4 -	30153-0022100	SUPPORTER BASE CAB AS	PP+FOAM-PU	1	1	1	1
B	1 5 -	30132-0000100	HOSE DRN A2	PVC	1	1	1	1
B	1 7 -	30111-0009100	CASE VAPORI AS	CASE VAPORI AS PP(RECYCLE 100%)	1	1	1	1
B	1 7 a	30111-0009001	CASE VAPORI	PP 100% SCRAP	1	1	1	1
B	1 7 b	60144-0027600	PIPE CONN A1	C1220T-O OD4.76 * TO.5 * L286	1	1	1	1
B	1 7 c	60118-0000801	FAN AS	FAN AS FR-S690CG OD130	1	1	1	1
B	1 7 d	60159-0010900	MOTOR C FAN	타파스12 1.8W 1500rpm RGE51	1	1	1	1
B	1 8 -		CASE VAPORI AS					A++
B	1 8 a		CASE VAPORI					A++
B	1 8 b		FAN OD110					A++
B	1 8 c		MOUTHBELL A1 35					A++
B	1 8 d		MOUTHBELL A2 35					A++
B	1 8 e	90007-0003700	SCREW TAPPING	T1 TRS 4*12 MFZN				A++
B	1 8 f	60101-0002000	ABSORBER F MOTR	ABSORBER F MOTR NBR				A++
B	1 8 g		OS MOTOR CFAN AC AS					A++
B	1 8 h	60101-0002000	ABSORBER F MOTR	ABSORBER F MOTR NBR				A++
B	1 8 i		FIXTURE C MOTOR AC 36					A++
B	1 8 j	30160-0004701	SCREW T1 TRS 4 12	SPECIAL SCREW T1 FLT 4X16				A++
B	1 8 k		PIPE WICON AS					A++

8-2. Parts List

NO	PART-CODE	PART NAME	SPEC.	Q'ty				Remark			
				RCP330	RCP360	RCT330	RCT360				
C> COVER M/F DUCT AS / D> EVAPORATOR AS / E> LOUVER F A											
C	-	30114-0098600	COVER M-FLOW DUCT AS	RCT33*, RCP33*	1		1				
C	1	30114-0098601			1		1	OPTION			
C	2	30114-0101600				1		1			
C	3	30114-0101601		RCT36*, RCP36*		1		1	OPTION		
C	0	1	a	30114-0091000	COVER M-FLOW DUCT	PP, RCT33*, RCP33*	1		1		
C				30114-0091100	COVER M-FLOW DUCT	PP, RCT36*, RCP36*		1		1	
C	0	1	b	30133-0021300	INSU M/FLOW DUCT	EPS, RCP33*	1		1		
C				30133-0021400	INSU M/FLOW DUCT	EPS, RCP36*		1		1	
C	0	1	c	90007-0003700	SCREW TAPPING	T1 TRS 4*12	2	2	2	2	
C	0	1	d	30109-0003600	CAP F LUVR	CAP F LOUVER HIPS T2.3	2	2	2	2	
C	0	1	e	30120-0023000	WINDOW VITA	GPSS RCP330,360	1	1	1	1	OPTION
C	0	1	f	90007-0005200	SCREW TAPPING	T2S PAN 3X8 MFZN	1	1	1	1	OPTION
C	0	1	g	60136-0001401	LAMP LED PCB AS	75x20x1.6T, LED-5	1	1	1	1	OPTION
C	0	1	h	60127-0014401	HARNESS R SENS AS	R-S+저항HTR+VITA LED	1	1	1	1	OPTION
C				60127-0014402		R-S+저항HTR	1	1	1	1	1
D	0	1	-	60170-0004101	EVA SAS	230VAC 160W HTR	1	1	1	1	
D	0	1	a	60128-0005203	HEATER SHEATH AS	230V 160W NEO-V	1	1	1	1	
D	0	1	b	1PBAXX-0001	CABLE TIE	W3.6X1.40	1	1	1	1	
D	0	1	f	60170-0004001	EVA SAS	NEO-V	1	1	1	1	
D	0	1	d	60127-0017901	HARNESS DEFR SENS	HARNESS D SENSOR NEO-V	1	1	1	1	
D	0	1	e	30120-0005200	FIXTURE DEFR SENS	FIXTURE DEFROST SENS PP	2	2	2	2	
D	0	2	-	30125-0009900	GUIDE DRN	GA, T0.4	1	1	1	1	
E	0	1	-	30189-0015100	LOUVER F AS	RCP330,360					
E	0	1	a	30189-0014200	LOUVER F A1	PP RCP330,360	1	1	1	1	
E	0	1	b	30134-0001900	KNOB F CONTL	KNOB F CONTL PP	1	1	1	1	
E	0	1	c	30189-0014300	LOUVER F A2	PP RCP330,360	1	1	1	1	
E	0	1	d	30112-0000101	CLAMP FAN	SUS 304 (SPRING) OD 9.7	1	1	1	1	
E	0	1	e	60118-0000700	FAN AS	ABS OD3.17XD110	1	1	1	1	
E	0	1	f	60101-0002000	ABSORBER F MOTR	ABSORBER F MOTR NBR	1	1	1	1	
E	0	1	g	60159-0010701	MOTOR F AS	D4612AAA41 DC10.84V 2000RPM	1	1	1	1	
E	0	1	h	60101-0002000	ABSORBER F MOTR	ABSORBER F MOTR NBR	1	1	1	1	
E	0	1	i	30120-0023000	FIXTURE MOTR *B	FIXTURE MOTR *B PP,DC	2	2	2	2	
E	0	1	j	30160-0004700	SPECIAL SCREW	FLAT,MFZN 4X10	1	1	1	1	
E	0	1	k	90007-0003500	SCREW TAPPING	T1 TRS 4*10 MFZN	1	1	1	1	
F> REFRIGERATOR COMPARTMENT / G> FREEZER COMPARTMENT											
F	0	1	-	30178-0032800	SHELF R AS	AL FILM RCP(T)330,360	2	3	2	3	
F	0	2	-	30178-0033800	SHELF WINE	SUS204	1	1	1	1	OPTION
F	0	3	-	30178-0033000	SHELF FRESH AS	GLASS T3.2	1	1	1	1	OPTION
F	0	4	-	30111-0051400	CASE FRESH AS	RCP330,360	1	1	1	1	OPTION
F	0	5	-	30116-0038900	DECO COVR VEGETB *F AS	RCP330,360	1	1	1	1	
F	0	6	-	30111-0051500	CASE VEGETB AS	WINDOW A1/A2(SILK PRINT)	1	1	1	1	
F	0	7	-	30111-0027100	CASE EGG TRAY AS	GPSS(CRYSTAL)+VINYL PAKG	1	1	1	1	
G	0	1	-	30111-0001100	CASE ICE AS	PP(J-360),+VINYL	1	1	1	1	
G	0	2	-	30111-0051200	CASE F A1 AS	CASE+WINDOW(SILK PRINT)	2	2	2	2	
G	0	3	-	30178-0032600	SHELF F GLAS	T3.2*W453*L236 RCP(T)330,360	2	2	2	2	
G	0	4	-	30111-0051300	CASE F A2 AS	CASE+WINDOW(SILK PRINT)	1	1	1	1	

8-2. Parts List

NO	PART-CODE	PART NAME	SPEC.	Q'ty				Remark
				RCP330	RCP360	RCT330	RCT360	
H> REFRIGERATOR DOOR / I> FREEZER DOOR								
H 0 1 -	30100-0217700	ASSY R DR ,ELLIO(MSG4E)	MSG4E, DISP, SIDE HNDL	1				330모델
H 0 1 -1	30100-0217706		MSG4E, DISP, GRIP HNDL	1				
H 0 1 -2	30100-0217701		MSG4E, NO DISP, SIDE HNDL	1				
H 0 1 -3	30100-0217707		MSG4E, NO DISP, GRIP HNDL	1				
H 0 1 -4	30100-0217704	ASSY R DR ,PCM(DWGIC)	DWGIC, DISP, SIDE HNDL	1				
H 0 1 -5	30100-0217710		DWGIC, DISP, GRIP HNDL	1				
H 0 1 -6	30100-0217702		DWGIC, NO DISP, SIDE HNDL	1				
H 0 1 -7	30100-0217708		DWGIC, NO DISP, GRIP HNDL	1				
H 0 1 -8	30100-0217711	ASSY R DR ,PCM(BLHIC)	BLHIC, DISP, SIDE HNDL	1				
H 0 1 -9	30100-0217706		BLHIC, DISP, GRIP HNDL	1				
H 0 1 -10	30100-0217703		BLHIC, NO DISP, SIDE HNDL	1				
H 0 1 -11	30100-0217709		BLHIC, NO DISP, GRIP HNDL	1				
H 0 1 -12	30100-0220900	ASSY R DR ,ELLIO(MSG4E)	MSG4E, DISP, SIDE HNDL		1			
H 0 1 -13	30100-0220906		MSG4E, DISP, GRIP HNDL		1			
H 0 1 -14	30100-0220901		MSG4E, NO DISP, SIDE HNDL		1			
H 0 1 -15	30100-0220907		MSG4E, NO DISP, GRIP HNDL		1			
H 0 1 -16	30100-0220904	ASSY R DR ,PCM(DWGIC)	DWGIC, DISP, SIDE HNDL		1			
H 0 1 -17	30100-0220910		DWGIC, DISP, GRIP HNDL		1			
H 0 1 -18	30100-0220902		DWGIC, NO DISP, SIDE HNDL		1			
H 0 1 -19	30100-0220908		DWGIC, NO DISP, GRIP HNDL		1			
H 0 1 -20	30100-0220911	ASSY R DR ,PCM(BLHIC)	BLHIC, DISP, SIDE HNDL		1			
H 0 1 -21	30100-0220906		BLHIC, DISP, GRIP HNDL		1			
H 0 1 -22	30100-0220903		BLHIC, NO DISP, SIDE HNDL		1			
H 0 1 -23	30100-0220909		BLHIC, NO DISP, GRIP HNDL		1			
H 0 2 -	30123-0014900	GASKET R DR AS	RCP(T)330 PVC-S	1				330모델
H 0 2 -1	30123-0015000	GASKET R DR AS	RCP(T)360 PVC-S		1			360모델
H 0 3 -	30130-0003100	HOLDER W TANK 510	LDPE,722 FRP-516	1	1			OPTION
H 0 4 -	30152-0004700	STOPPER W/TANK *L	ABS 1*4 RGE48	1	1			OPTION
H 0 5 -	30152-0002800	STOPPER W/TANK *R	ABS 1*4 RGE48	1	1			OPTION
H 0 6 -	30114-0090600	COVER R DR CAP *T	ABS	1	1			
H 0 7 -	90007-0003700	SCREW TAPPING	T1 TRS 4*12	2	2			
H 0 8 -	30126-0013800	HANDLE A TYPE ASSY	RCP330,360	1	1			OPTION
H 0 8 -1		HANDLE B TYPE ASSY	RCP330,360	1	1			OPTION
H 1 9 -	30160-0005400	SPECIAL SCREW HNDL	M5 L16	2	2			OPTION
H 1 0 -	30109-0019300	CAP HNDL	ABS	2	2			OPTION
H 1 1 -	30190-0029600	POCKET DAIRY AS	RCP330,360	1	1			OPTION
H 1 1 a	30190-0027600	POCKET DAIRY	GPPS NEO-V	1	1			OPTION
H 1 1 b	30114-0101000	COVER DAIRY POKT PR	GPPS SILK PRINT RCP330,360	1	1			OPTION
H 1 1 -	30190-0027400	POCKET R A1	GPPS NEO-V	1	2			OPTION
H 1 2 -	30190-0029800	POCKET R A3	GPPS NEO-V	1	1			OPTION
H 1 4 -	30182-0004700	WATER TANK AS	RCP330,360	1	1			OPTION
H 1 4 a	30114-0090900	COVER W/TANK	LDPE NEO-V	1	1			OPTION
H 1 4 b	30182-0004500	TANK WATER	GPPS NEO-V	1	1			OPTION
H 1 4 c	30109-0049100	CAP COVR W/TANK	SILICON	1	1			OPTION
H 1 5 -	30190-0027500	POCKET R A2	GPPS NEO-V	1	1			
H 1 6 -	30190-0030100	POCKET JUMBO AS	GPPS SILK PRINT	1	1			
H 1 7 -	60142-0027600	PANEL CONTL *F AS	ABS RCP330,360	1	1			
H 1 7 a	30155-0026100	WINDOW FCP AS	RCP330,361	1	1			
H 1 7 b	60142-0025700	PANEL CONTL *F	ABS NEO V-PJT	1	1			
H 1 7 c	40301-0101900	REF PCB FRONT ASSY	NEO-V 63.4 X 196 1.6T FR-1	1	1			
H 1 7 d	90007-0005200	SCREW TAPPING	T2S PAN 3X8 MFZN	6	6			
H 1 8 -	60142-0027700	PANEL DISPNS AS	RCP330,360	1	1			OPTION
H 1 8 a	30116-0032900	DECO PANL W/DISPNS	ABS FILM 1*2	1	1			OPTION
H 1 8 b	30116-0032801	DECO W/DISPNS	ABS CR 1*2 RCP3**	1	1			OPTION
H 1 8 c	30122-0039400	FRAME DECO W/DISPNS	RCP330,360 DELUXE	1	1			OPTION
H 1 8 d	30151-0001900	SPRING DISPNS LEVR	STS304 0.8TX7 FRP-513	1	1			OPTION
H 1 8 e	30137-0004900	LEVER DISPNS	ABS FILM 1*2	1	1			OPTION
H 1 9 -	30120-0016500	FIXTURE A10	ABS	2	2			OPTION
H 2 0 -	30160-0008101	SPECIAL BOLT STOPR DR	TAP-TITE 5*16	1	1			
H 1 8 -1	60142-0022400	DECO DISPNS AS	SILK PRINT,WHITE	1	1			OPTION
H 1 8 -2	60142-0022401		SILK PRINT+SPRAY	1	1			OPTION
H 1 8 a	30116-0029400	DECO DISPNS AS	SPRAY RGE48	1	1			OPTION
H 1 8 b	30116-0029500		SILK PRINT	1	1			OPTION
H 1 8 b	3014263900	PANEL DISPNS	ABS	1	1			OPTION
H 1 8 d	3015103600	SPRING DISPNS LEVR	STS304 0.8T*7	1	1			OPTION
H 1 8 e	3013706000	LEVER DISPNS	GPPS	1	1			OPTION

8-2. Parts List

NO	PART-CODE	PART NAME	SPEC.	Q'ty				Remark	
				RCP330	RCP360	RCT330	RCT360		
J> FREEZER DOOR / K> REFRIGERATOR DOOR									
J	0 1	30100-0220700	ASSY R DR	MILAN WHITE, RCT330, SIDE HNDL			1	330모델	
J	0 1 -1	30100-0220701		STEEL SILVER, RCT330, SIDE HNDL			1		
J	0 1 -2	30100-0220702		WAVE BLACK, RCT33, SIDE HNDL			1		
J	0 1 -3	30100-0220703		SOLID BLACK, RCT330, SIDE HNDL			1		
J	0 1 -4	30100-0220800	ASSY R DR	MILAN WHITE, RCT360, SIDE HNDL			1	360모델	
J	0 1 -5	30100-0220801		STEEL SILVER, RCT360, SIDE HNDL			1		
J	0 1 -6	30100-0220802		WAVE BLACK, RCT360, SIDE HNDL			1		
J	0 1 -7	30100-0220803		SOLID BLACK, RCT360 SIDE HNDL			1		
J	0 2	-	30123-0014900	GASKET R DR AS	RCP(T)330 PVC-S		1	330모델	
J		-1	30123-0015000	GASKET R DR AS	RCP(T)360 PVC-S			1	360모델
J	0 3	-	30120-0028400	FIXTURE FCP AS	WHITE		1	1	
J		-	30120-0028401		SILVER,			1	1
J		-	30120-0028402		BLACK			1	1
J	0 3	a	30120-0012801	FIXTURE PCB	WHITE, SILVER, BLACK, ABS		1	1	
J	3 3	b	40301-0102401	REF PCB SUB ASSY	WHITE		1	1	
J				40301-0102400	SILVER, BLACK			1	1
J	0 3	c	60127-0023901	HARNESS R DR AS	GLASS DOOR		1	1	
J	0 4	-	30114-0090600	COVER R DR CAP *T	ABS		1	1	
J	0 5	-	90007-0003700	SCREW TAPPING	T1 TRS 4*12		2	2	
J	0 6	-	30152-0002701	STOPPER R DR	PO, T2.6		1	1	
J	0 7	-	90007-0003700	SCREW TAPPING	T1 TRS 4*12		2	2	
J	0 8	-	30190-0029600	POCKET DAIRY AS	RCP330,360		1	1	
J	0 8	a	30190-0027600	POCKET DAIRY	GPPS NEO-V		1	1	
J	0 8	b	30114-0101000	COVER DAIRY POKT PR	GPPS SILK PRINT RCP330,360		1	1	
J	0 9	-	30190-0027400	POCKET R A1	GPPS NEO-V		1	1	
J	1 0	-	30190-0027500	POCKET R A2	GPPS NEO-V		1	1	
J	1 1	-	30190-0030100	POCKET JUMBO PR	GPPS SILK PRINT NEO-V		1	1	
K> REFRIGERATOR DOOR									
K	0 1	-	30100-0220600	ASSY F DR	MILAN WHITE		1	1	
K	0 1	-1	30100-0220601		STEEL SILVER			1	1
K	0 1	-2	30100-0220602		WAVE BLACK			1	1
K	0 1	-3	30100-0220603		SOLID BLACK			1	1
K	0 2	-	30123-0014800	GASKET F DR AS	RCP(T)330,360 PVC-S		1	1	
K	0 3	-	30160-0008101	SPECIAL BOLT STOPR DR	TAP-TITE 5*16		1	1	