

5. EXPLODED VIEWS AND PARTS LIST



[MATERIAL CODE STANDARDS]

Material codes and names and their respective naming rules are managed in accordance with the prescribed standards. Please refer to these standards when requesting a material.

1. Material Code Type

● : Number

■ : Letter (Alphabet)

Type 1	 ex) 0204-000418 FREON	Enterprise-wide parts Type 1 materials can be used for all Samsung Electronics products. (Most electrical parts belong to this type.)
Type 2	 ex) DC96-01390A ASSY-CONTROL	Division-wide parts (DC**-Washing machine) Type 2 materials can be used for specific products. (Most instruments and tools belong to this type.)

2. Ass'y Materials

All ass'y material codes start with DC9*.

An ass'y material is created by combining more than two materials. If a requested material cannot be provided, you can request an ass'y material that contains that material.

5-1. MAIN (SDC18809/XEN)

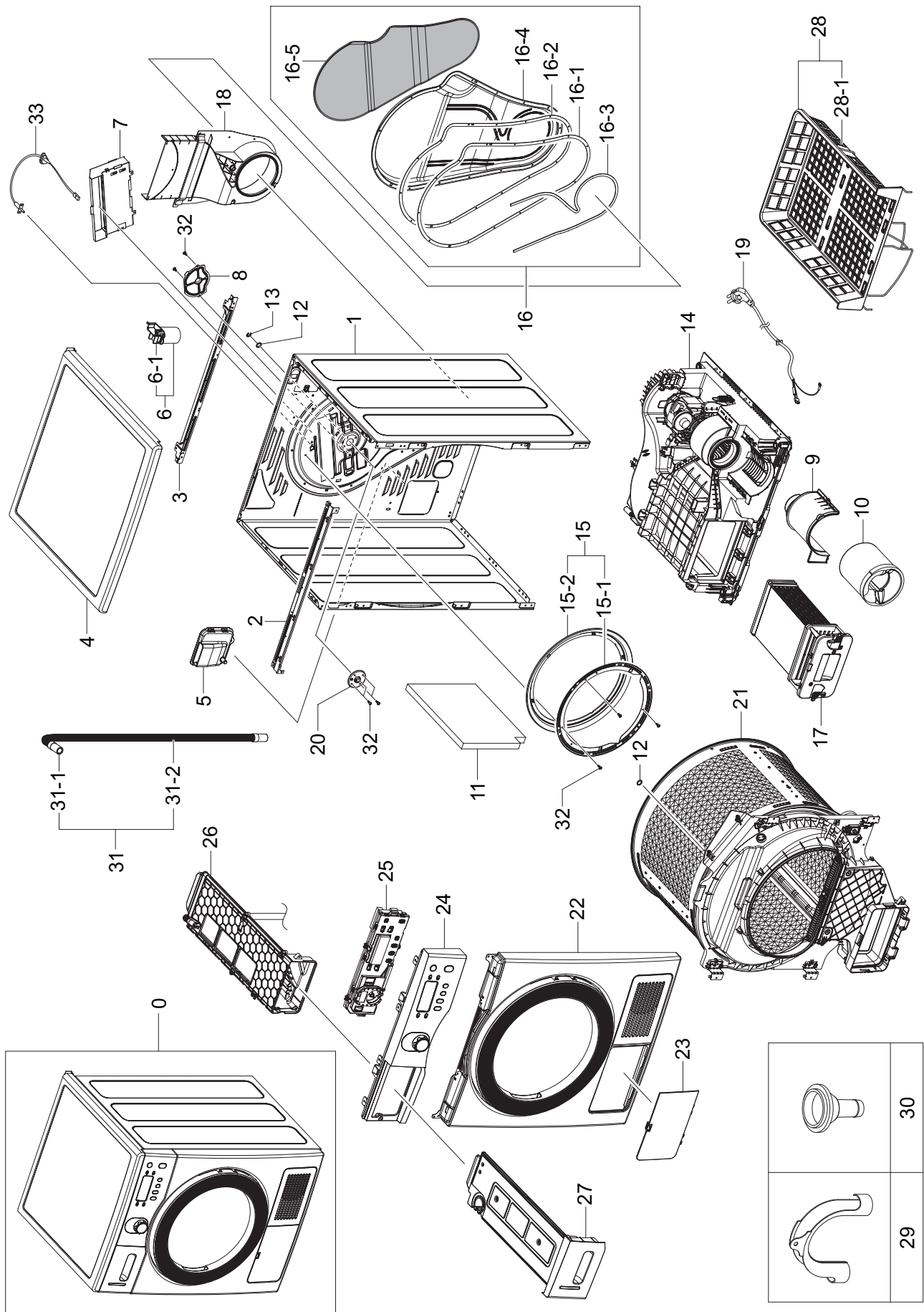

MODEL CODE: SDC18809/XEN

Service Bom (SA: SERVICE AVAILABLE, SNA: SERVICE NOT AVAILABLE)

Drawing No.	Code No.	Description	Specification	QTY	Un	SA/SNA
0	SDC18809/XEN	ASSY-CLOTHES DRYER	D100-DRYER			
1	DC61-02489A	FRAME	SDC18809,PCM(GI),WHT,T0.8,W598/D525,L792,SGEC	1	PC	SNA
2	DC61-02261A	FRAME-PLATE(U)	DCVH480EK0WW,GI,T1.2,W44,L587,GE24-DRYER / 299g	1	PC	SA
3	DC61-02267B	BRACKET-COVER TOP	SDC18809,GI,T1.0,W42,L587	1	PC	SNA
4	DC97-14953Q	ASSY COVER TOP	D100,SDC18809,ABS+WOOD,W594.2xD590.3,WHT	1	PC	SA
5	DC61-02609A	GUIDE-HOSE DRAIN	SDC18809,PP,T2.0,W116.7,L111.8,NTR	1	PC	SA
6	DC93-00157A	ASSY CONDENSER	450VAC 8MFD,SDC18809	1	PC	SA
6-1	2501-001339	C-OIL	8uF,450V,BK,40x55mm,16mm	1	PC	SA
7	DC47-00030B	HEATER-DRY	119283,D100,CrAl,2500W,7.6A,3.2A,230V,28.6ohm,67.3ohm,238*142*44,230V,1750W+750W	1	PC	SA
8	DC63-01263A	COVER-BEARING	SDC18809,EGI,T0.8,W108.6,L92,NTR	1	PC	SNA
9	DC63-01089A	COVER-FAN(C/F)	SDC18809,PP,W198,L162,NTR,D100-PJT	1	PC	SNA
10	DC63-01105A	ABSORBER-SOUND	SDC18809,PU-FOAM,T30,H145.2,D152.5,GRY,ROUND SHAPE	1	PC	SA
11	DC63-01158A	ABSORBER-SOUND(F)	SDC18809,PU-FOAM,T20,W350,L250,GRY,D100	1	PC	SA
12	6031-002038	WASHER-PLAIN	NYLON,ID12,OD17,T1.0,NTR	2	PC	SNA
13	6044-001784	RING-C	ID11.1,STW-12,T1.0,BLK,STC5	1	PC	SNA
14	DC90-02691A	ASSY BASE	D100-PJT,SDC-18809	1	PC	SNA
15	DC93-00072A	ASSY GASKET FELT	GE24-DRYER,DCVH480EK,-,-,-,-	1	PC	SA
15-1	DC61-02263A	BRACKET-GASKET FELT	DCVH480EK0WW,STS430,T0.5,W335.4,L335.4,GE24-DRYER / 107g	1	PC	SA
15-2	DC93-00093A	ASSY GASKET FELT-SUB	GE24-DRYER,DCVH480EKWW,STS430/EPDM	1	PC	SA
16	DC93-00103A	ASSY COVER DUCT	D100 PJT,SDC18809	1	PC	SA
16-1	DC62-00288A	SEAL-COVER DUCT(F)	SDC18809,CR,BLK,T2.0,W10,L617,D100	2	PC	SA
16-2	DC62-00288B	SEAL-COVER DUCT(F)	SDC18809,CR,BLK,T3.0,W10,L617,D100	1	PC	SA
16-3	DC62-00289A	SEAL-COVER DUCT(G)	SDC18809,CR,BLK,T3.0,W10,L395,D100	3	PC	SA
16-4	DC63-01100A	COVER-DUCT	SDC-18809,GI,T0.6,W486,L689.4,NTR,D100-PJT	1	PC	SNA
16-5	DC72-00080A	SPONGE-COVER DUCT	SDC18809,PE-FOAM,T5.0,W349,L679,GRY,D100	1	PC	SA
17	DC93-00115A	ASSY CONDENSER	D100,SDC-18809	1	PC	SNA
18	DC93-00135A	ASSY GUIDE DUCT FAN	D100 PJT,SDC18809,PP+EPDM FOAM	1	PC	SNA
19	DC96-00146B	ASSY POWER CORD	250V/16A,UCP2,DRYER	1	PC	SA
20	DC97-16288A	ASSY HOUSING BEARING	D100-PJT,SDC18809,8kg,OILLESS BEARING	1	PC	SA

MODEL CODE: SDC18809/XENService Bom (**SA**: SERVICE AVAILABLE, **SNA**: SERVICE NOT AVAILABLE)

Drawing No.	Code No.	Description	Specification	QTY	Un	SA/SNA
21		ASSY DRUM & ASSY DRUM FRONT(R)	D100-DRYER,SDC18809/XEN	1	PC	SNA
22	DC97-15980A	ASSY FRONT	D100,SDC18809,WHT FRAME/CR DOOR	1	PC	SNA
23	DC63-01081A	COVER-CONDENSER(F)	SDC18809,ABS,W245,L152.2,WHT,D100-PJT	1	PC	SNA
24		ASSY-PANEL CONTROL & KNOB ENCODER	Refer to 5.3 ASSY PANEL CONTROL	1		
25	DC92-00272A	ASSY PCB MAIN	D100,D100 BEST,230V/50Hz,Y,SMPS,TNY277,9W	1	PC	SNA
26	DC97-15938A	ASSY HOUSING DRAWER	D100 PJT,SDC18809,PP,L562	1	PC	SNA
27	DC97-15763A	ASSY DRAWER	D100-PJT,SDC18809	1	PC	SNA
28	DC93-00134A	ASSY DIE RACK DRY	D100 PJT,SDC18809,PP+MSWR,DRY	1	PC	SNA
28-1	DC61-02472A	DIE-RACK DRY	SDC18809,PP,L404,W319.5,GRY,FC2305	1	PC	SA
29	DC62-10278A	HOSE-HANGER	PP,NTR,JS20 RESIN	1	PC	SNA
30	DC61-02479A	GUIDE-HOSE	SDC18809,PP,T1.5,L34.5,NTR,D100	1	PC	SNA
31	DC97-15757C	ASSY HOSE DRAIN	D100,SDC18809,L1998,ID9.5,GRY	1	PC	SA
31-1	DC61-02469A	BUSH-HOSE	SDC18809,EPDM+PP,ID9.6,OD15.5,L32,GRY	2	PC	SNA
31-2	DC67-00424C	HOSE-DRAIN	SDC18809,PP,ID8,OD13,T0.8,L1950,GRY	1	PC	SA
32	6002-000239	SCREW-TAPPING	TH,+,- ,2S,M4,L8,ZPC(WHT),SWRCH18A,-	4	PC	SA
32	6002-000239	SCREW-TAPPING	TH,+,- ,2S,M4,L8,ZPC(WHT),SWRCH18A,-	3	PC	SA
32	6002-000239	SCREW-TAPPING	TH,+,- ,2S,M4,L8,ZPC(WHT),SWRCH18A,-	2	PC	SA
33	DC90-10128P	ASSY THERMISTOR	5V,-20~170°C,RESISTOR,SUS 30mm	1	PC	SA

MEMO

MAIN (SDC16809/XEF)

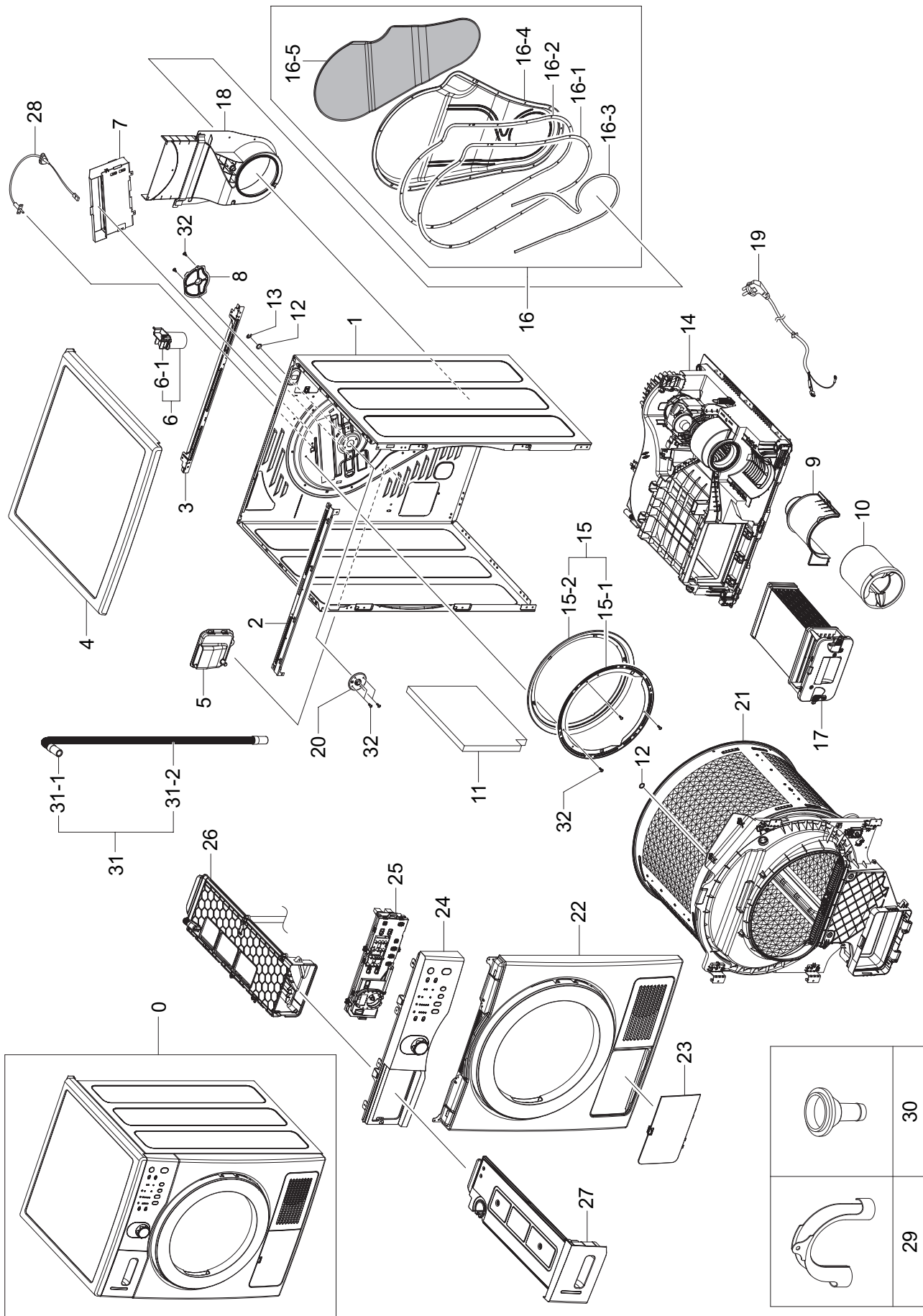

MODEL CODE: SDC16809/XEF

Service Bom (SA: SERVICE AVAILABLE, SNA: SERVICE NOT AVAILABLE)

Drawing No.	Code No.	Description	Specification	QTY	Un	SA/SNA
0	SDC16809/XEF	ASSY-CLOTHES DRYER	D100-DRYER			
1	DC61-02489A	FRAME	SDC18809,GI-SGCC,WHT,T0.8,W598/D525,L792,SGEC	1	PC	SNA
2	DC61-02261A	FRAME-PLATE(U)	DCVH480EK0WW,GI,T1.2,W44,L587,GE24-DRYER / 299g	1	PC	SA
3	DC61-02267B	BRACKET-COVER TOP	SDC18809,GI,T1.0,W42,L587	1	PC	SNA
4	DC97-14953Q	ASSY COVER TOP	D100,SDC18809,ABS+WOOD,W594.2xD590.3,WHT	1	PC	SA
5	DC61-02609A	GUIDE-HOSE DRAIN	SDC18809,PP,T2.0,W116.7,L111.8,NTR	1	PC	SA
6	DC93-00157A	ASSY CONDENSER	450VAC 8MFD,SDC18809	1	PC	SA
6-1	2501-001339	C-OIL	8uF,450V,BK,40x55mm,16mm	1	PC	SA
7	DC47-00030B	HEATER-DRY	119283,D100,CrAl,2500W,7.6A,3.2A,230V,28.6ohm,67.3ohm,238*142*44,230V,1750W+750W	1	PC	SA
8	DC63-01263A	COVER-BEARING	SDC18809,EGI,T0.8,W108.6,L92,NTR	1	PC	SNA
9	DC63-01089A	COVER-FAN(C/F)	SDC18809,PP,W198,L162,NTR,D100-PJT	1	PC	SNA
10	DC63-01105A	ABSORBER-SOUND	SDC18809,PU-FOAM,T30,H145.2,D152.5,GRY,ROUND SHAPE	1	PC	SA
11	DC63-01158A	ABSORBER-SOUND(F)	SDC18809,PU-FOAM,T20,W350,L250,GRY,D100	1	PC	SA
12	6031-002038	WASHER-PLAIN	NYLON,ID12,OD17,T1.0,NTR	2	PC	SNA
13	6044-001784	RING-C	ID11.1,STW-12,T1.0,BLK,STC5	1	PC	SNA
14	DC90-02691B	ASSY BASE	D100-PJT,SDC-16809	1	PC	SNA
15	DC93-00072A	ASSY GASKET FELT	GE24-DRYER,DCVH480EK,-,-,-,-	1	PC	SA
15-1	DC61-02263A	BRACKET-GASKET FELT	DCVH480EK0WW,STS430,T0.5,W335.4,L335.4,GE24-DRYER / 107g	1	PC	SA
15-2	DC93-00093A	ASSY GASKET FELT-SUB	GE24-DRYER,DCVH480EKWW,STS430/EPDM	1	PC	SA
16	DC93-00103A	ASSY COVER DUCT	D100 PJT,SDC18809	1	PC	SA
16-1	DC62-00288A	SEAL-COVER DUCT(F)	SDC18809,CR,BLK,T2.0,W10,L617,D100	2	PC	SA
16-2	DC62-00288B	SEAL-COVER DUCT(F)	SDC18809,CR,BLK,T3.0,W10,L617,D100	1	PC	SA
16-3	DC62-00289A	SEAL-COVER DUCT(G)	SDC18809,CR,BLK,T3.0,W10,L395,D100	3	PC	SA
16-4	DC63-01100A	COVER-DUCT	SDC-18809,GI,T0.6,W486,L689.4,NTR,D100-PJT	1	PC	SNA
16-5	DC72-00080A	SPONGE-COVER DUCT	SDC18809,PE-FOAM,T5.0,W349,L679,GRY,D100	1	PC	SA
17	DC93-00115A	ASSY CONDENSER	D100,SDC-18809	1	PC	SNA
18	DC93-00135A	ASSY GUIDE DUCT FAN	D100 PJT,SDC18809,PP+EPDM FOAM	1	PC	SNA
19	DC96-00146B	ASSY POWER CORD	250V/16A,UCP2,DRYER	1	PC	SA
20	DC97-16288A	ASSY HOUSING BEARING	D100-PJT,SDC18809,8kg,OILLESS BEARING	1	PC	SA

MODEL CODE: SDC16809/XEFService Bom (**SA**: SERVICE AVAILABLE, **SNA**: SERVICE NOT AVAILABLE)

Drawing No.	Code No.	Description	Specification	QTY	Un	SA/SNA
21		ASSY DRUM & ASSY DRUM FRONT(R)	D100-DRYER,SDC18809/XEN	1	PC	SNA
22	DC97-15980B	ASSY FRONT	D100,SDC16809,WHT FRAME/WH DOOR	1	PC	SNA
23	DC63-01081A	COVER-CONDENSER(F)	SDC18809,ABS,W245,L152.2,WHT,D100-PJT	1	PC	SNA
24		ASSY-PANEL CONTROL & KNOB ENCODER	Refer to 5.3 ASSY PANEL CONTROL	1		
25	DC92-00397A	ASSY PCB MAIN	D100,D100 BETTER/GOOD,230V/50Hz,Y,SMPS, TNY277,9W	1	PC	SNA
26	DC97-15938A	ASSY HOUSING DRAWER	D100 PJT,SDC18809,PP,L562	1	PC	SNA
27	DC97-15763A	ASSY DRAWER	D100-PJT,SDC18809	1	PC	SNA
28	DC90-10128P	ASSY THERMISTOR	5V,-20~170°C,RESISTOR,SUS 30mm	1	PC	SA
29	DC62-10278A	HOSE-HANGER	PP,NTR,JS20 RESIN	1	PC	SNA
30	DC61-02479A	GUIDE-HOSE	SDC18809,PP,T1.5,L34.5,NTR,D100	1	PC	SNA
31	DC97-15757C	ASSY HOSE DRAIN	D100,SDC18809,L1998,ID9.5,GRY	1	PC	SA
31-1	DC61-02469A	BUSH-HOSE	SDC18809,EPDM+PP,ID9.6,OD15.5,L32,GRY	2	PC	SNA
31-2	DC67-00424C	HOSE-DRAIN	SDC18809,PP,ID8,OD13,T0.8,L1950,GRY	1	PC	SA
32	6002-000239	SCREW-TAPPING	TH,+,-,2S,M4,L8,ZPC(WHT),SWRCH18A,-	4	PC	SA
32	6002-000239	SCREW-TAPPING	TH,+,-,2S,M4,L8,ZPC(WHT),SWRCH18A,-	3	PC	SA
32	6002-000239	SCREW-TAPPING	TH,+,-,2S,M4,L8,ZPC(WHT),SWRCH18A,-	2	PC	SA

MEMO

MAIN (SDC14709/XEE)

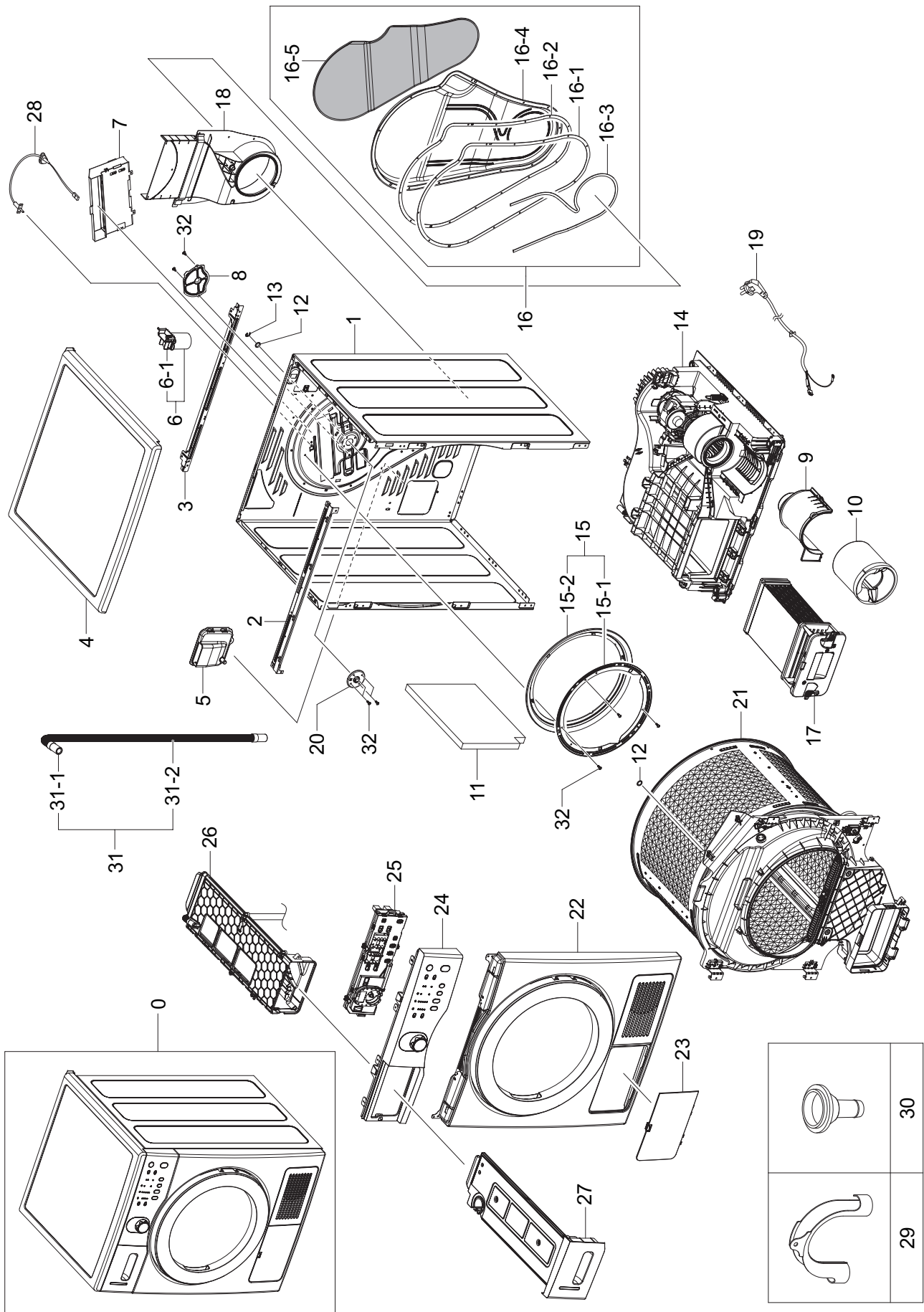

MODEL CODE: SDC14709/XEE

Service Bom (SA: SERVICE AVAILABLE, SNA: SERVICE NOT AVAILABLE)

Drawing No.	Code No.	Description	Specification	QTY	Un	SA/SNA
0	SDC14709/XEE	ASSY-CLOTHES DRYER	D100-DRYER			
1	DC61-02489A	FRAME	SDC18809,GI-SGCC,WHT,T0.8,W598/D525,L792,SGEC	1	PC	SNA
2	DC61-02261A	FRAME-PLATE(U)	DCVH480EK0WW,GI,T1.2,W44,L587,GE24-DRYER / 299g	1	PC	SA
3	DC61-02267B	BRACKET-COVER TOP	SDC18809,GI,T1.0,W42,L587	1	PC	SNA
4	DC97-14953Q	ASSY COVER TOP	D100,SDC18809,ABS+WOOD,W594.2xD590.3,WHT	1	PC	SA
5	DC61-02609A	GUIDE-HOSE DRAIN	SDC18809,PP,T2.0,W116.7,L111.8,NTR	1	PC	SA
6	DC93-00157A	ASSY CONDENSER	450VAC 8MFD,SDC18809	1	PC	SA
6-1	2501-001339	C-OIL	8uF,450V,BK,40x55mm,16mm	1	PC	SA
7	DC47-00030B	HEATER-DRY	119283,D100,CrAl,2500W,7.6A,3.2A,230V,28.6ohm,67.3ohm,238*142*44,230V,1750W+750W	1	PC	SA
8	DC63-01263A	COVER-BEARING	SDC18809,EGI,T0.8,W108.6,L92,NTR	1	PC	SNA
9	DC63-01089A	COVER-FAN(C/F)	SDC18809,PP,W198,L162,NTR,D100-PJT	1	PC	SNA
10	DC63-01105A	ABSORBER-SOUND	SDC18809,PU-FOAM,T30,H145.2,D152.5,GRY,ROUND SHAPE	1	PC	SA
11	DC63-01158A	ABSORBER-SOUND(F)	SDC18809,PU-FOAM,T20,W350,L250,GRY,D100	1	PC	SA
12	6031-002038	WASHER-PLAIN	NYLON,ID12,OD17,T1.0,NTR	2	PC	SNA
13	6044-001784	RING-C	ID11.1,STW-12,T1.0,BLK,STC5	1	PC	SNA
14	DC90-02691B	ASSY BASE	D100-PJT,SDC-16809	1	PC	SNA
15	DC93-00072A	ASSY GASKET FELT	GE24-DRYER,DCVH480EK,-,-,-,-	1	PC	SA
15-1	DC61-02263A	BRACKET-GASKET FELT	DCVH480EK0WW,STS430,T0.5,W335.4,L335.4,GE24-DRYER / 107g	1	PC	SA
15-2	DC93-00093A	ASSY GASKET FELT-SUB	GE24-DRYER,DCVH480EKWW,STS430/EPDM	1	PC	SA
16	DC93-00103A	ASSY COVER DUCT	D100 PJT,SDC18809	1	PC	SA
16-1	DC62-00288A	SEAL-COVER DUCT(F)	SDC18809,CR,BLK,T2.0,W10,L617,D100	2	PC	SA
16-2	DC62-00288B	SEAL-COVER DUCT(F)	SDC18809,CR,BLK,T3.0,W10,L617,D100	1	PC	SA
16-3	DC62-00289A	SEAL-COVER DUCT(G)	SDC18809,CR,BLK,T3.0,W10,L395,D100	3	PC	SA
16-4	DC63-01100A	COVER-DUCT	SDC-18809,GI,T0.6,W486,L689.4,NTR,D100-PJT	1	PC	SNA
16-5	DC72-00080A	SPONGE-COVER DUCT	SDC18809,PE-FOAM,T5.0,W349,L679,GRY,D100	1	PC	SA
17	DC93-00115A	ASSY CONDENSER	D100,SDC-18809	1	PC	SNA
18	DC93-00135A	ASSY GUIDE DUCT FAN	D100 PJT,SDC18809,PP+EPDM FOAM	1	PC	SNA
19	DC96-00146B	ASSY POWER CORD	250V/16A,UCP2,DRYER	1	PC	SA
20	DC97-16288A	ASSY HOUSING BEARING	D100-PJT,SDC18809,8kg,OILLESS BEARING	1	PC	SA

MODEL CODE: SDC14709/XEE

Service Bom (SA: SERVICE AVAILABLE, SNA: SERVICE NOT AVAILABLE)

Drawing No.	Code No.	Description	Specification	QTY	Un	SA/SNA
21		ASSY DRUM & ASSY DRUM FRONT(R)	D100-DRYER,SDC18809/XEN	1	PC	SNA
22	DC97-15980C	ASSY FRONT	D100,SDC14709,WHT FRAME/WH DOOR	1	PC	SNA
23	DC63-01081A	COVER-CONDENSER(F)	SDC18809,ABS,W245,L152.2,WHT,D100-PJT	1	PC	SNA
24		ASSY-PANEL CONTROL & KNOB ENCODER	Refer to 5.3 ASSY PANEL CONTROL	1		
25	DC92-00397A	ASSY PCB MAIN	D100,D100 BETTER/GOOD,230V/50Hz,Y,SMPS, TNY277,9W	1	PC	SNA
26	DC97-15938A	ASSY HOUSING DRAWER	D100 PJT,SDC18809,PP,L562	1	PC	SNA
27	DC97-15763A	ASSY DRAWER	D100-PJT,SDC18809	1	PC	SNA
28	DC90-10128P	ASSY THERMISTOR	5V,-20~170°C,RESISTOR,SUS 30mm	1	PC	SA
29	DC62-10278A	HOSE-HANGER	PP,NTR,JS20 RESIN	1	PC	SNA
30	DC61-02479A	GUIDE-HOSE	SDC18809,PP,T1.5,L34.5,NTR,D100	1	PC	SNA
31	DC97-15757C	ASSY HOSE DRAIN	D100,SDC18809,L1998,ID9.5,GRY	1	PC	SA
31-1	DC61-02469A	BUSH-HOSE	SDC18809,EPDM+PP,ID9.6,OD15.5,L32,GRY	2	PC	SNA
31-2	DC67-00424C	HOSE-DRAIN	SDC18809,PP,ID8,OD13,T0.8,L1950,GRY	1	PC	SA
32	6002-000239	SCREW-TAPPING	TH,+,-,2S,M4,L8,ZPC(WHT),SWRCH18A,-	4	PC	SA
32	6002-000239	SCREW-TAPPING	TH,+,-,2S,M4,L8,ZPC(WHT),SWRCH18A,-	3	PC	SA
32	6002-000239	SCREW-TAPPING	TH,+,-,2S,M4,L8,ZPC(WHT),SWRCH18A,-	2	PC	SA

MEMO

5-2. ASS'Y DOOR&FRONT FRAME (SDC18809/XEN)

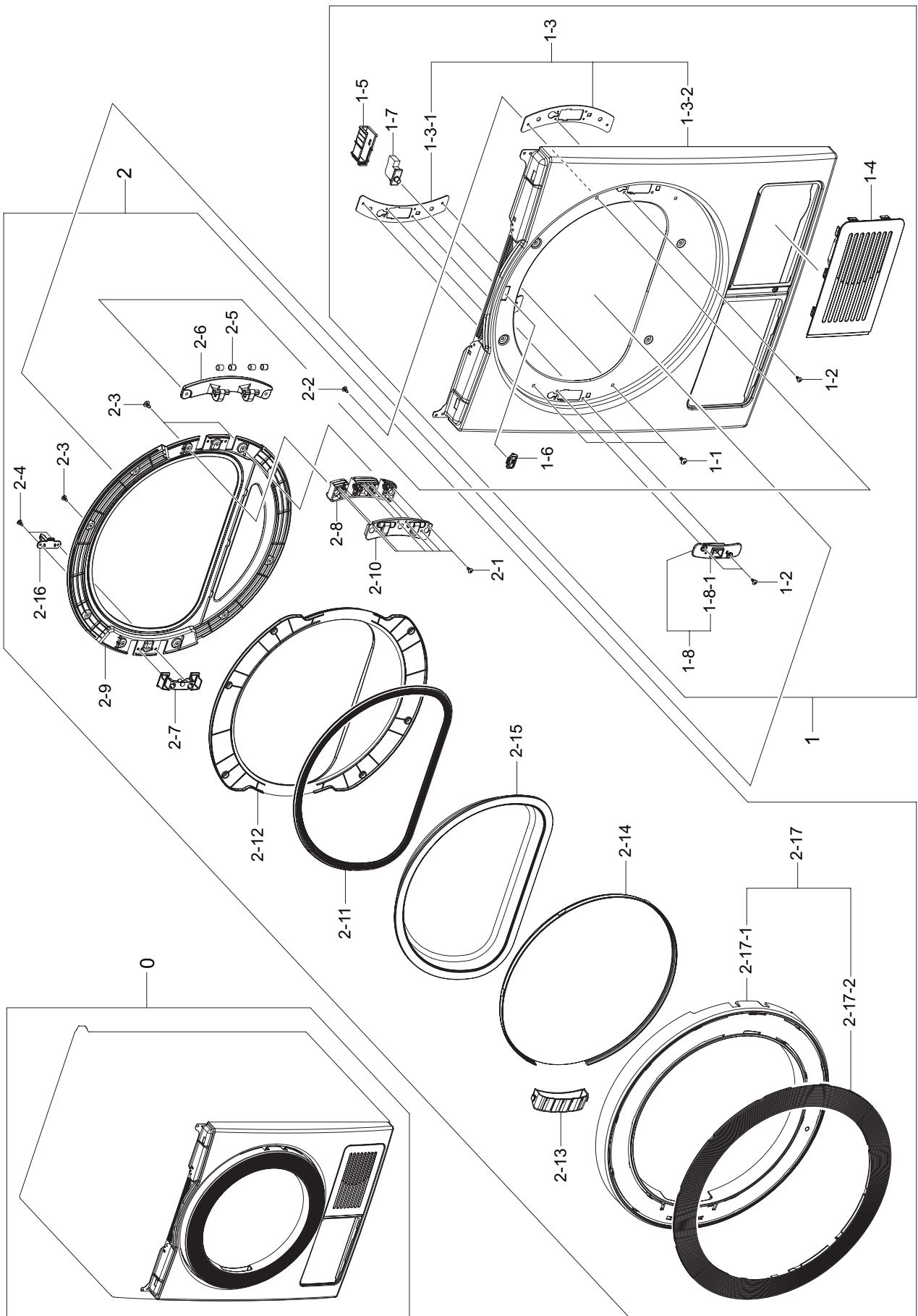

MODEL CODE: SDC18809/XEN

Service Bom (SA: SERVICE AVAILABLE, SNA: SERVICE NOT AVAILABLE)

Drawing No.	Code No.	Description	Specification	QTY	Un	SA/SNA
0	DC97-15980A	ASSY FRONT	D100,SDC18809,WHT FRAME/CR DOOR	1	PC	SNA
1	DC97-15759A	ASSY FRAME FRONT	D100 PJT,SDC18809	1	PC	SA
1-1	6001-001773	SCREW-MACHINE	TH,+,-,M5,L12,PASS,STS430,-,SEAL-LOCK	2	PC	SA
1-2	6002-001006	SCREW-TAPPING	TH,+,-,2S,M4,L12,PASS,STS430,-	1	PC	SNA
1-2	6002-001006	SCREW-TAPPING	TH,+,-,2S,M4,L12,PASS,STS430,-	2	PC	SNA
1-3	DC97-16526A	ASSY FRAME FRONT(S)	D100 PJT,SDC18809,WHT	1	PC	SA
1-3-1	DC61-02283A	BRACKET-HINGE	DCVH480EK0WW,HGI,T2.0,W35,L202,N ATURAL,GE 24 DRYER / 83g	2	PC	SA
1-3-2	DC61-02464A	FRAME-FRONT	D100_DRYER,EGI,T0.8,W595,L665.2	1	PC	SNA
1-4	DC63-01082A	COVER-FRONT	SDC18809,ABS,W249.4,L152.6,WHT,D 100-PJT	1	PC	SNA
1-5	DC63-01098A	COVER-SWITCH	SDC18809,ABS+PC,T3.0,W63,L34,D1 00-PJT	1	PC	SNA
1-6	DC63-01226A	COVER-SWITCH(F)	SDC18809,PP,W60.8,L35,GRY	1	PC	SA
1-7	DC64-00828D	DOOR-S/W	NYLON,T13.6,H34,W4.3,WHT,120V/15A	1	PC	SA
1-8	DC97-15505B	ASSY HOLDER LEVER	D100,SDC18809,DARK HOLDER GRAY	1	PC	SNA
1-8-1	DC61-02253B	HOLDER-LEVER	D100,POM,DARK HOLDER GRAY	1	PC	SA
2	DC97-15760A	ASSY DOOR	D100 PJT,SDC18809	1	PC	SA
2-1	6002-000215	SCREW-TAPPING	TH,+,-,NO,1,M4,L16,ZPC(WHT),SWRC H18A	6	PC	SNA
2-2	6002-000241	SCREW-TAPPING	TH,+,-,2S,M5,L12,ZPC(WHT),SWRCH18A,-	1	PC	SA
2-3	6002-000444	SCREW-TAPPING	TH,+,-,2,M4,L14,PASS,STS430	11	PC	SNA
2-3	6002-000444	SCREW-TAPPING	TH,+,-,2,M4,L14,PASS,STS430	1	PC	SNA
2-3	6002-000444	SCREW-TAPPING	TH,+,-,2,M4,L14,PASS,STS430	2	PC	SNA
2-4	6002-000445	SCREW-TAPPING	TH,+,-,2,M4,L18,PASS,STS304	2	PC	SA
2-5	DC61-00891A	GUIDE-HINGE	HAUZEN(DOM),POM,-,-,-,WHT,HINGE	4	PC	SA
2-6	DC61-02252A	HINGE-DOOR	GE24-DRYER,ALDC,T3.0,W47.1,L200,M EAALLIC-SILVER	1	PC	SA
2-7	DC61-02455A	GUIDE-HOLDER GLASS	SDC18809,PP,W86,L31,GRY,D100 PJT	1	PC	SNA
2-8	DC61-02456A	HOLDER-HINGE	SDC18809,PP,W140,L19,GRY,D100-PJT	1	PC	SNA
2-9	DC61-02460A	HOLDER-GLASS	SDC18809,PP,W479.4,GRY,D100-PJT	1	PC	SNA
2-10	DC61-02462A	SUPPORT-HINGE	SDC18809,SBHG1-A(SGCC),T1.4,W143,D100-PJT,73g	1	PC	SNA
2-11	DC62-00277A	SEAL-DOOR	SDC18809,TPE,GRY,W8,D100 PJT	1	PC	SA
2-12	DC63-01080B	COVER-DOOR(I)	SDC18809,ABS,W464,BLACK,D100-PJT	1	PC	SNA
2-13	DC64-01998A	HANDLE-DOOR	SDC18809,ABS,W113.4,L25.8,GRAY,D 100 PJT	1	PC	SA
2-14	DC64-02001A	DOOR-SAFETY	SDC18809,PET,T2.8,W375.5,TRP	1	PC	SA
2-15	DC64-02226A	DOOR-GLASS	SDC18809,Tempered GLASS,T5.0,W398,L300,TRP	1	PC	SA
2-16	DC66-00536A	LEVER-DOOR	GE24-DRYER,ZNDC,W52.0,L31.0,NI PLANTING	1	PC	SA
2-17	DC97-15761A	ASSY COVER DOOR	D100 PJT,SDC18809,ABS,T3.5	1	PC	SA

MODEL CODE: SDC18809/XENService Bom (**SA**: SERVICE AVAILABLE, **SNA**: SERVICE NOT AVAILABLE)

Drawing No.	Code No.	Description	Specification	QTY	Un	SA/SNA
2-17-1	DC63-01079A	COVER-DOOR	SDC18809,ABS,T3.0,W480,DA WHT,CR COAT/DECO	1	PC	SNA
2-17-2	DC64-01523A	DECORATION-COVER DOOR	WF8804DP,ABS,T2.7,W450,L450,-,BLK,-	1	PC	SNA

MEMO

ASS'Y DOOR&FRONT FRAME (SDC16809/XEF)

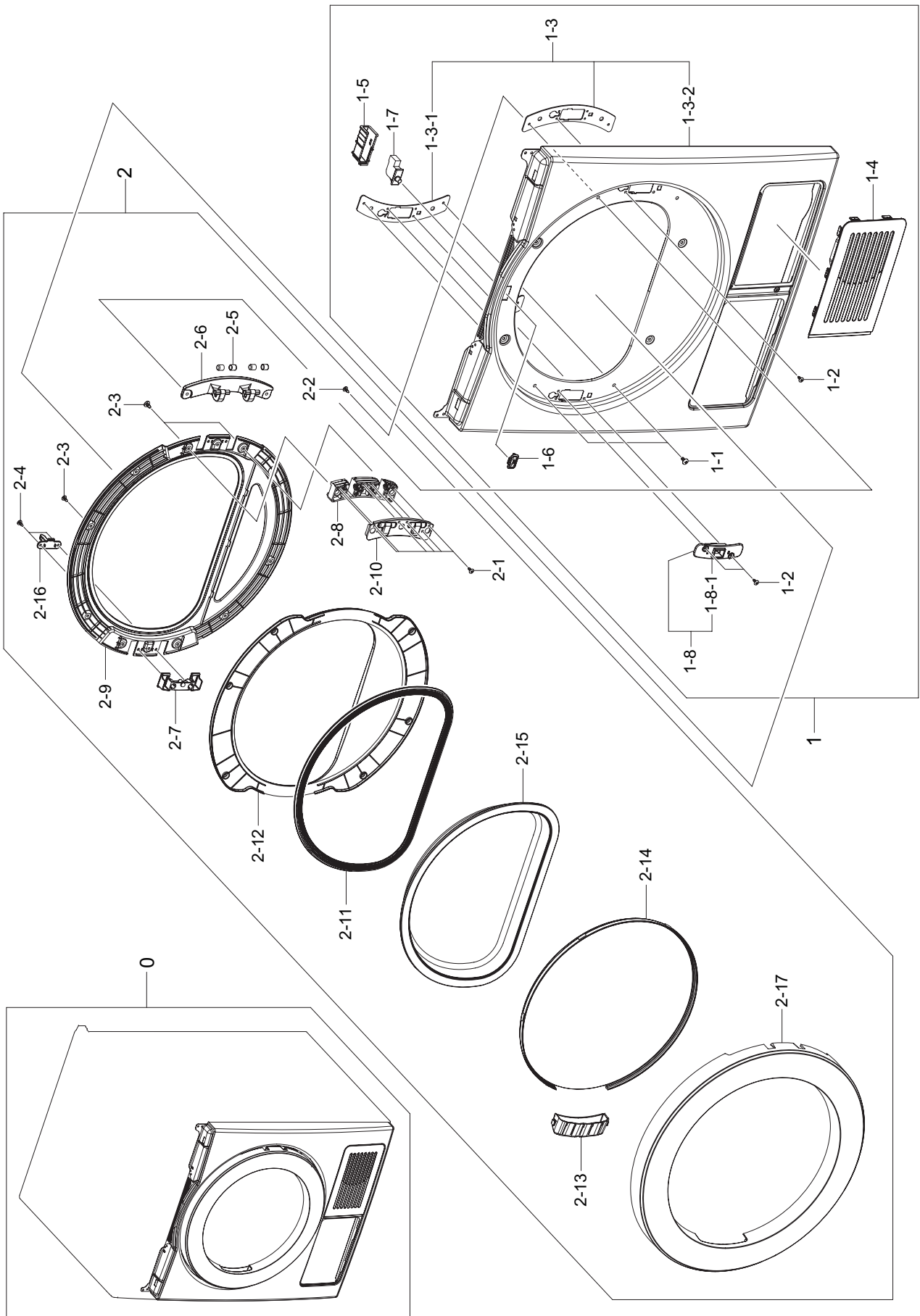

MODEL CODE: SDC16809/XEF

Service Bom (SA: SERVICE AVAILABLE, SNA: SERVICE NOT AVAILABLE)

Drawing No.	Code No.	Description	Specification	QTY	Un	SA/SNA
0	DC97-15980B	ASSY FRONT	D100,SDC16809,WHT FRAME/WH DOOR	1	PC	SNA
1	DC97-15759A	ASSY FRAME FRONT	D100 PJT,SDC18809	1	PC	SA
1-1	6001-001773	SCREW-MACHINE	TH,+,-,M5,L12,PASS,STS430,-,SEAL-LOCK	2	PC	SA
1-2	6002-001006	SCREW-TAPPING	TH,+,-,2S,M4,L12,PASS,STS430,-	1	PC	SNA
1-2	6002-001006	SCREW-TAPPING	TH,+,-,2S,M4,L12,PASS,STS430,-	2	PC	SNA
1-3	DC97-16526A	ASSY FRAME FRONT(S)	D100 PJT,SDC18809,WHT	1	PC	SA
1-3-1	DC61-02283A	BRACKET-HINGE	DCVH480EK0WW,HGI,T2.0,W35,L202,N ATURAL,GE 24 DRYER / 83g	2	PC	SA
1-3-2	DC61-02464A	FRAME-FRONT	D100_DRYER,EGI,T0.8,W595,L665.2	1	PC	SNA
1-4	DC63-01082A	COVER-FRONT	SDC18809,ABS,W249.4,L152.6,WHT,D 100-PJT	1	PC	SNA
1-5	DC63-01098A	COVER-SWITCH	SDC18809,ABS+PC,T3.0,W63,L34,D1 00-PJT	1	PC	SNA
1-6	DC63-01226A	COVER-SWITCH(F)	SDC18809,PP,W60.8,L35,GRY	1	PC	SA
1-7	DC64-00828D	DOOR-SW	NYLON,T13.6,H34,W4.3,WHT,120V/15A	1	PC	SA
1-8	DC97-15505B	ASSY HOLDER LEVER	D100,SDC18809,DARK HOLDER GRAY	1	PC	SNA
1-8-1	DC61-02253B	HOLDER-LEVER	D100,POM,DARK HOLDER GRAY	1	PC	SA
2	DC97-15764A	ASSY DOOR	D100 PJT,SDC16809(BETTER)	1	PC	SA
2-1	6002-000215	SCREW-TAPPING	TH,+,-,NO,1,M4,L16,ZPC(WHT),SWRC H18A	6	PC	SNA
2-2	6002-000241	SCREW-TAPPING	TH,+,-,2S,M5,L12,ZPC(WHT),SWRCH18A,-	1	PC	SA
2-3	6002-000444	SCREW-TAPPING	TH,+2,M4,L14,PASS,STS430	11	PC	SNA
2-3	6002-000444	SCREW-TAPPING	TH,+2,M4,L14,PASS,STS430	1	PC	SNA
2-3	6002-000444	SCREW-TAPPING	TH,+2,M4,L14,PASS,STS430	2	PC	SNA
2-4	6002-000445	SCREW-TAPPING	TH,+2,M4,L18,PASS,STS304	2	PC	SA
2-5	DC61-00891A	GUIDE-HINGE	HAUZEN(DOM),POM,-,-,WHT,HINGE	4	PC	SA
2-6	DC61-02252A	HINGE-DOOR	GE24-DRYER,ALDC,T3.0,W47.1,L200,M EAALLIC-SILVER	1	PC	SA
2-7	DC61-02455A	GUIDE-HOLDER GLASS	SDC18809,PP,W86,L31,GRY,D100 PJT	1	PC	SNA
2-8	DC61-02456A	HOLDER-HINGE	SDC18809,PP,W140,L19,GRY,D100-PJT	1	PC	SNA
2-9	DC61-02460A	HOLDER-GLASS	SDC18809,PP,W479.4,GRY,D100-PJT	1	PC	SNA
2-10	DC61-02462A	SUPPORT-HINGE	SDC18809,SBHG1-A(SGCC),T1.4,W143,D100-PJT,73g	1	PC	SNA
2-11	DC62-00277A	SEAL-DOOR	SDC18809,TPE,GRY,W8,D100 PJT	1	PC	SA
2-12	DC63-01080A	COVER-DOOR(I)	SDC16809,ABS,W464,DA WHT,D100-PJT	1	PC	SNA
2-13	DC64-01998B	HANDLE-DOOR	SDC16809,ABS,W113.4,L25.8,DA WHT,D100 PJT	1	PC	SA
2-14	DC64-02001A	DOOR-SAFETY	SDC18809,PET,T2.8,W375.5,TRP	1	PC	SA
2-15	DC64-02226A	DOOR-GLASS	SDC18809,Tempered GLASS,T5.0,W398,L300,TRP	1	PC	SA
2-16	DC66-00536A	LEVER-DOOR	GE24-DRYER,ZNDC,W52.0,L31.0,NI PLANTING	1	PC	SA
2-17	DC63-01086A	COVER-DOOR	SDC16809,ABS,W480,DA WHT,D100- PJT	1	PC	SNA

ASS'Y DOOR&FRONT FRAME (SDC14709/XEE)

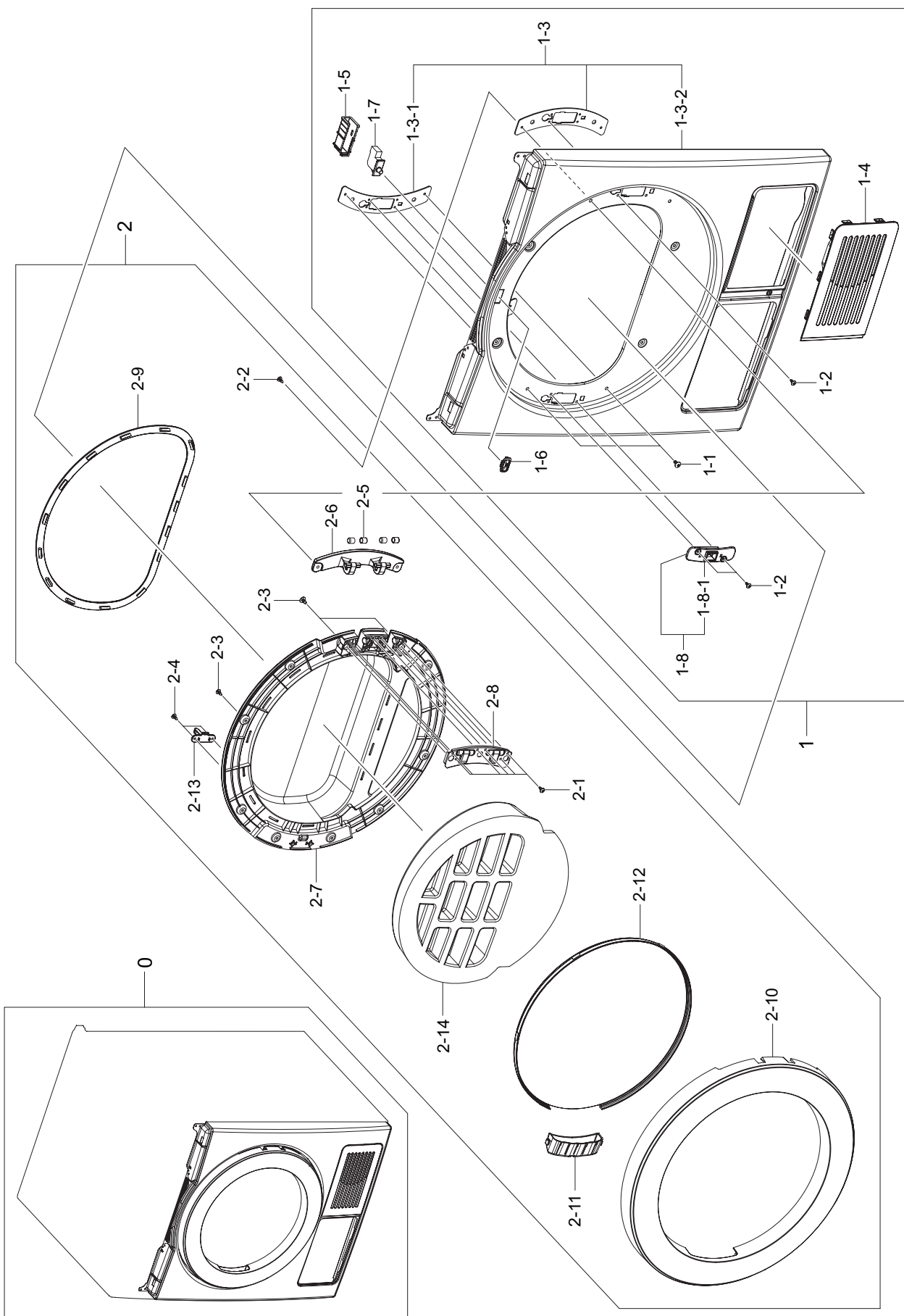

MODEL CODE: SDC14709/XEE

Service Bom (SA: SERVICE AVAILABLE, SNA: SERVICE NOT AVAILABLE)

Drawing No.	Code No.	Description	Specification	QTY	Un	SA/SNA
0	DC97-15980C	ASSY FRONT	D100,SDC14709,WHT FRAME/WH DOOR	1	PC	SNA
1	DC97-15759A	ASSY FRAME FRONT	D100 PJT,SDC18809	1	PC	SA
1-1	6001-001773	SCREW-MACHINE	TH,+,-,M5,L12,PASS,STS430,-,SEAL-LOCK	2	PC	SA
1-2	6002-001006	SCREW-TAPPING	TH,+,-,2S,M4,L12,PASS,STS430,-	1	PC	SNA
1-2	6002-001006	SCREW-TAPPING	TH,+,-,2S,M4,L12,PASS,STS430,-	2	PC	SNA
1-3	DC97-16526A	ASSY FRAME FRONT(S)	D100 PJT,SDC18809,WHT	1	PC	SA
1-3-1	DC61-02283A	BRACKET-HINGE	DCVH480EK0WW,HGI,T2.0,W35,L202,N ATURAL,GE 24 DRYER / 83g	2	PC	SA
1-3-2	DC61-02464A	FRAME-FRONT	D100_DRYER,EGI,T0.8,W595,L665.2	1	PC	SNA
1-4	DC63-01082A	COVER-FRONT	SDC18809,ABS,W249.4,L152.6,WHT,D 100-PJT	1	PC	SNA
1-5	DC63-01098A	COVER-SWITCH	SDC18809,ABS+PC,T3.0,W63,L34,D1 00-PJT	1	PC	SNA
1-6	DC63-01226A	COVER-SWITCH(F)	SDC18809,PP,W60.8,L35,GRY	1	PC	SA
1-7	DC64-00828D	DOOR-S/W	NYLON,T13.6,H34,W4.3,WHT,120V/15A	1	PC	SA
1-8	DC97-15505B	ASSY HOLDER LEVER	D100,SDC18809,DARK HOLDER GRAY	1	PC	SNA
1-8-1	DC61-02253B	HOLDER-LEVER	D100,POM,DARK HOLDER GRAY	1	PC	SA
2	DC97-15765A	ASSY DOOR	D100 PJT,SDC16809(GOOD)	1	PC	SA
2-1	6002-000215	SCREW-TAPPING	TH,+ ,NO,1,M4,L16,ZPC(WHT),SWRC H18A	6	PC	SNA
2-2	6002-000241	SCREW-TAPPING	TH,+,- ,2S,M5,L12,ZPC(WHT),SWRCH18A,-	1	PC	SA
2-3	6002-000444	SCREW-TAPPING	TH,+2,M4,L14,PASS,STS430	11	PC	SNA
2-4	6002-000445	SCREW-TAPPING	TH,+2,M4,L18,PASS,STS304	2	PC	SA
2-5	DC61-00891A	GUIDE-HINGE	HAUZEN(DOM),POM,-,-,WHT,HINGE	4	PC	SA
2-6	DC61-02252A	HINGE-DOOR	GE24-DRYER,ALDC,T3.0,W47.1,L200,M EAALLIC-SILVER	1	PC	SA
2-7	DC61-02461A	HOLDER-GLASS	SDC14709,PP,W479,GRY,D100- PJT(GOOD MODEL)	1	PC	SNA
2-8	DC61-02462A	SUPPORT-HINGE	SDC18809,SBHG1- A(SGCC),T1.4,W143,D100-PJT,73g	1	PC	SNA
2-9	DC62-00293A	SEAL-DOOR	SDC14709,TPE,GRY,W16.6,L1155,D10 0 GOOD	1	PC	SNA
2-10	DC63-01080A	COVER-DOOR(I)	SDC16809,ABS,W464,DA WHT,D100- PJT	1	PC	SNA
2-11	DC63-01086A	COVER-DOOR	SDC16809,ABS,W480,DA WHT,D100- PJT	1	PC	SNA
2-12	DC64-01998B	HANDLE-DOOR	SDC16809,ABS,W113.4,L25.8,DA WHT,D100 PJT	1	PC	SA
2-13	DC64-02001B	DOOR-SAFETY	SDC14709,ABS,T2.8,W375.5,DA WHT	1	PC	SA
2-14	DC66-00536A	LEVER-DOOR	GE24-DRYER,ZNDC,W52.0,L31.0,NI PLANTING	1	PC	SA
2-15	DC69-01310A	CUSHION-DOOR	SDC14709,EPS,W362.8,H75.8	1	PC	SNA

5-3. ASS'Y PANEL CONTROL (SDC18809/XEN)

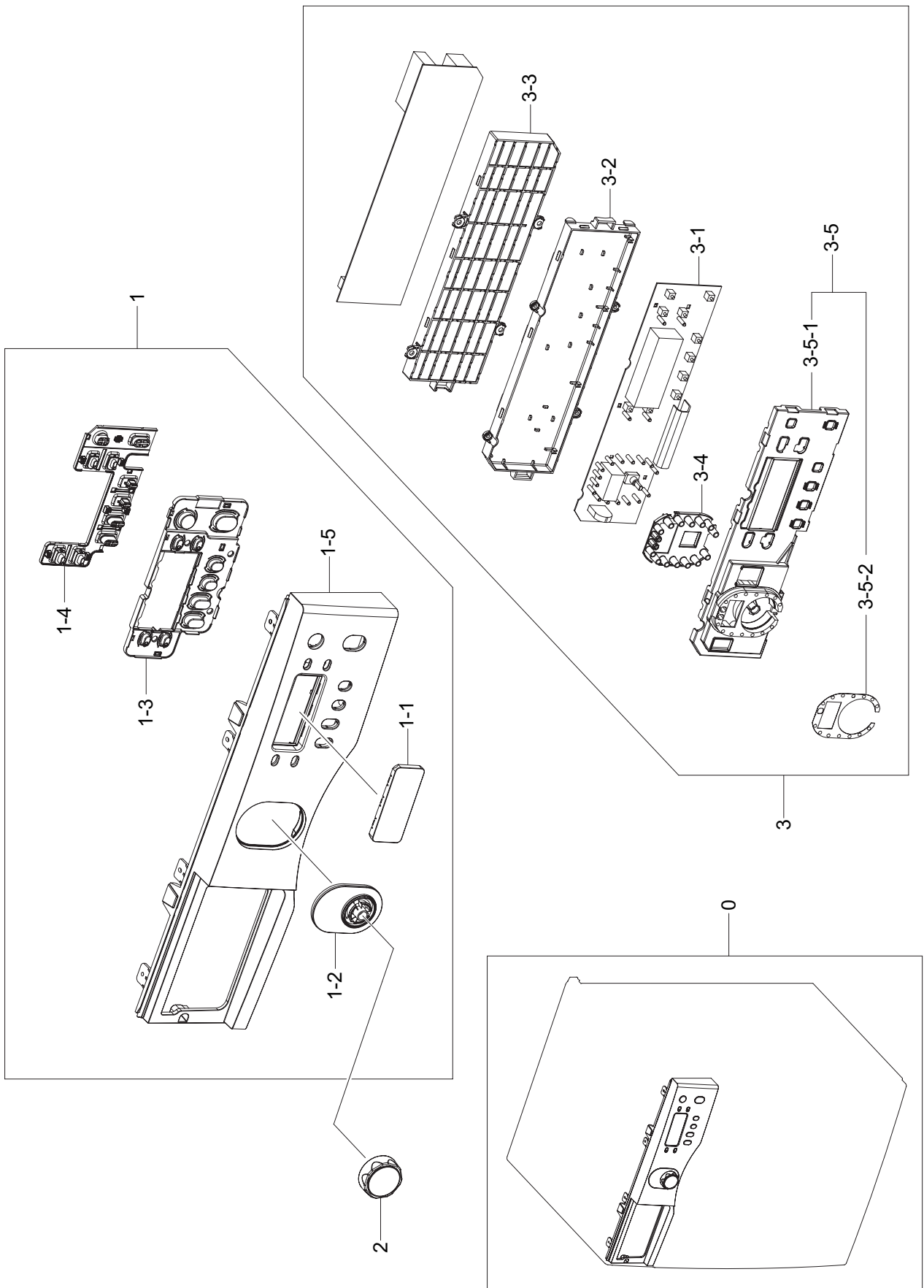

MODEL CODE: SDC18809/XENService Bom (**SA**: SERVICE AVAILABLE, **SNA**: SERVICE NOT AVAILABLE)

Drawing No.	Code No.	Description	Specification	QTY	Un	SA/SNA
0		ASSY-PANEL CONTROL & KNOB ENCODER		1		
1	DC97-15762A	ASSY PANEL CONTROL	D100-PJT,SDC18809	1	PC	SNA
1-1	DC64-01531A	WINDOW-PANEL	HEBA-PJT,ABS,T2.0,-,-,-,BLK,HIGH	1	PC	SNA
1-2	DC64-01533A	WINDOW-ENCODER	HEBA,ABS,T2.0,-,-,-,BLK,HIGH/MID	1	PC	SNA
1-3	DC64-02003A	BUTTON-PUSH(F)	SDC18809,ABS,DA-WHT,BEST	1	PC	SA
1-4	DC64-02004A	BUTTON-RUBBER	SDC18809, SILICON,NTR,HARDNESS45	1	PC	SA
1-5	DC64-02005A	PANEL-CONTROL	SDC18809,ABS,W594,WHT,BEST	1	PC	SA
2	DC97-14576A	ASSY KNOB ENCODER	WF8804DP,HIGH-DESIGN/8.0kg/ENG/ Ag+,Airwash/Anti leakage,-,-	1	PC	SA
3	DC92-00272A	ASSY PCB MAIN	D100,D100 BEST,230V/50Hz,Y,SMPS,TNY277,9W	1	PC	SNA
3-1	DC41-00129A	PCB-MAIN	D100 BEST,FR- 1,1,1.0,T1.6,W327*L197,Above 600V	1	PC	SA
3-2	DC61-01941A	GUIDE-PCB(S)	HEBA-PJT,ABS(V0),T2.0,-,-,WHT,HIGH/ MID/ (UL94- 5VA GRADE)	1	PC	SNA
3-3	DC61-02342A	GUIDE-PCB(M)	GE24-DRYER,ABS+PC,T3.0,W97.1,L33 5.5,GRY,5VA GRADE	1	PC	SNA
3-4	DC64-01560A	DECORATION-LED	HEBA-PJT,ABS,T2.7,W50,L550,- ,TRANSPARENCY,-	1	PC	SNA
3-5	DC97-14969A	ASSY COVER PCB	HEBA-PJT,HIPS+PET,-,-,-,-	1	PC	SNA
3-5-1	DC63-00861A	COVER-PCB(S)	HEBA-PJT,HIPS,T2.0,-,-,-,-,GRY,HIGH	1	PC	SNA
3-5-2	DC64-01607A	INLAY-ENCODER	HEBA,PET,T0.188,W22.2,L9.6,BLK,-	1	PC	SNA

ASS'Y PANEL CONTROL (SDC16809/XEF)

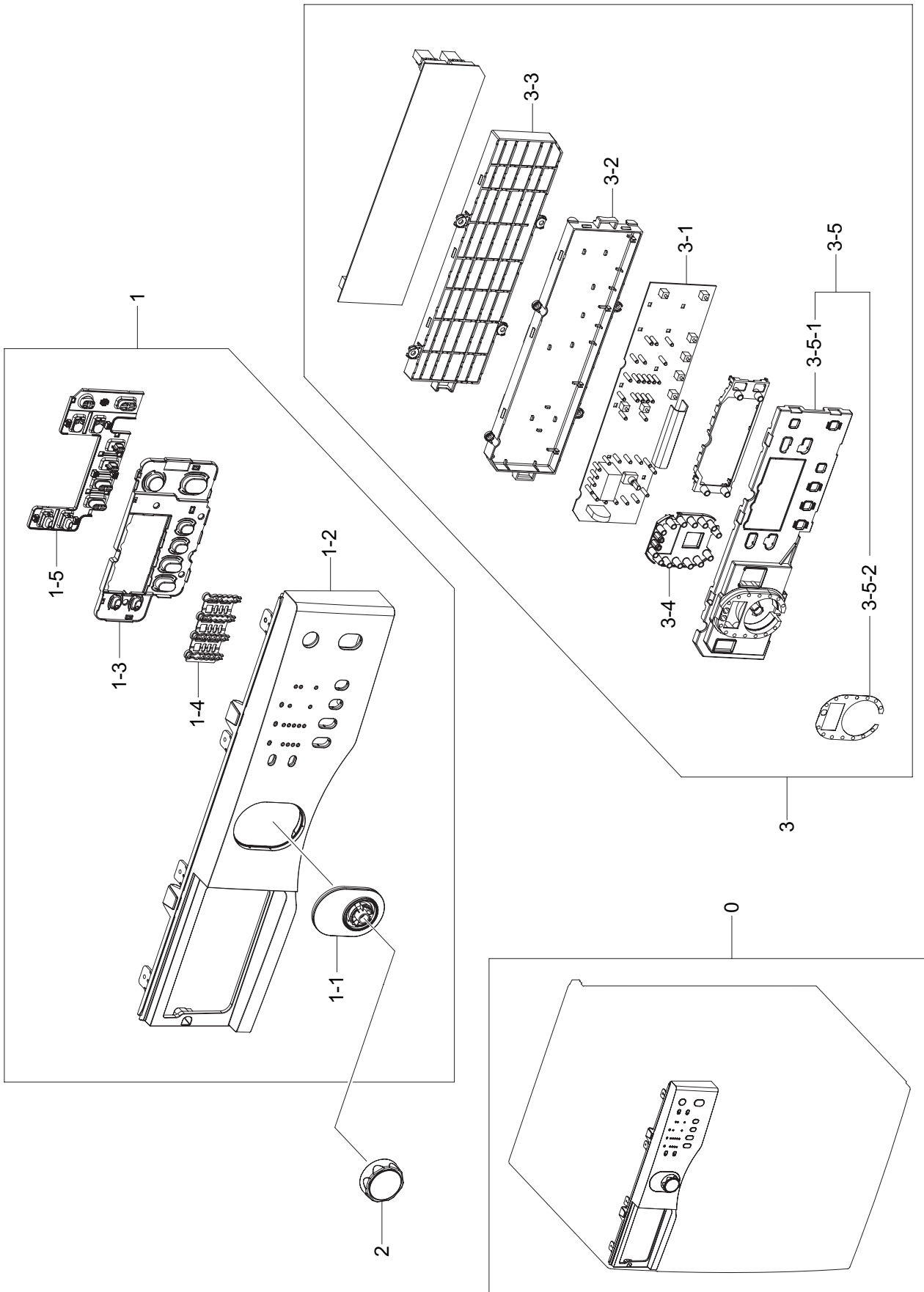

MODEL CODE: SDC16809/XEF

Service Bom (SA: SERVICE AVAILABLE, SNA: SERVICE NOT AVAILABLE)

Drawing No.	Code No.	Description	Specification	QTY	Un	SA/SNA
0		ASSY-PANEL CONTROL & KNOB ENCODER		1		
1	DC97-15853A	ASSY PANEL CONTROL	D100-PJT,SDC16809,DA WHT,BETTER	1	PC	SNA
1-1	DC64-01533A	WINDOW-ENCODER	HEBA,ABS,T2.0,-,-,-,BLK,HIGH/MID	1	PC	SNA
1-2	DC64-02008A	PANEL-CONTROL	SDC16809,ABS,W593.2,L52,WHT,BETTER	1	PC	SA
1-3	DC64-02009A	BUTTON-PUSH(F)	SDC16809,ABS,DA WHT,BETTER	1	PC	SA
1-4	DC64-02010A	DECORATION-LED	SDC16809,ABS,L6.8,TRP,BETTER	1	PC	SA
1-5	DC64-02011A	BUTTON-RUBBER	SDC16809,SILICON,TRP,HARDNESS45	1	PC	SA
2	DC97-14576B	ASSY KNOB ENCODER	WF8804SS,mid-DESIGN/8.0kg/ENG/Ag+,Airwash/Anti leakage,-,-	1	PC	SA
3	DC92-00397A	ASSY PCB MAIN	D100,D100 BETTER/ GOOD,230V/50Hz,Y,SMPS,TNY277,9W	1	PC	SNA
3-1	DC41-00134A	PCB-MAIN	D100 BETTER,GOOD,FR-1,1,1.0,T1.6,W327*L197,Above 600V	1	PC	SA
3-2	DC61-01941A	GUIDE-PCB(S)	HEBA-PJT,ABS(V0),T2.0,-,-,WHT,HIGH/MID/ (UL94- 5VA GRADE)	1	PC	SNA
3-3	DC61-02342A	GUIDE-PCB(M)	GE24-DRYER,ABS+PC,T3.0,W97.1,L335.5,GRY,5VA GRADE	1	PC	SNA
3-4	DC64-01560A	DECORATION-LED	HEBA-PJT,ABS,T2.7,W50,L550,-,TRANSPARENCY,-	1	PC	SNA
3-5	DC97-14969C	ASSY COVER PCB	HEBA-PJT,COVER PCB(S) MID TYPE+PET,-,-,-,-	1	PC	SA
3-5-1	DC63-00861B	COVER-PCB(S)	HEBA-PJT,HIPS,T2.0,-,-,-,-,BLK,MID	1	PC	SNA
3-5-2	DC64-01607A	INLAY-ENCODER	HEBA,PET,T0.188,W22.2,L9.6,BLK,-	1	PC	SNA

ASS'Y PANEL CONTROL (SDC14709/XEE)

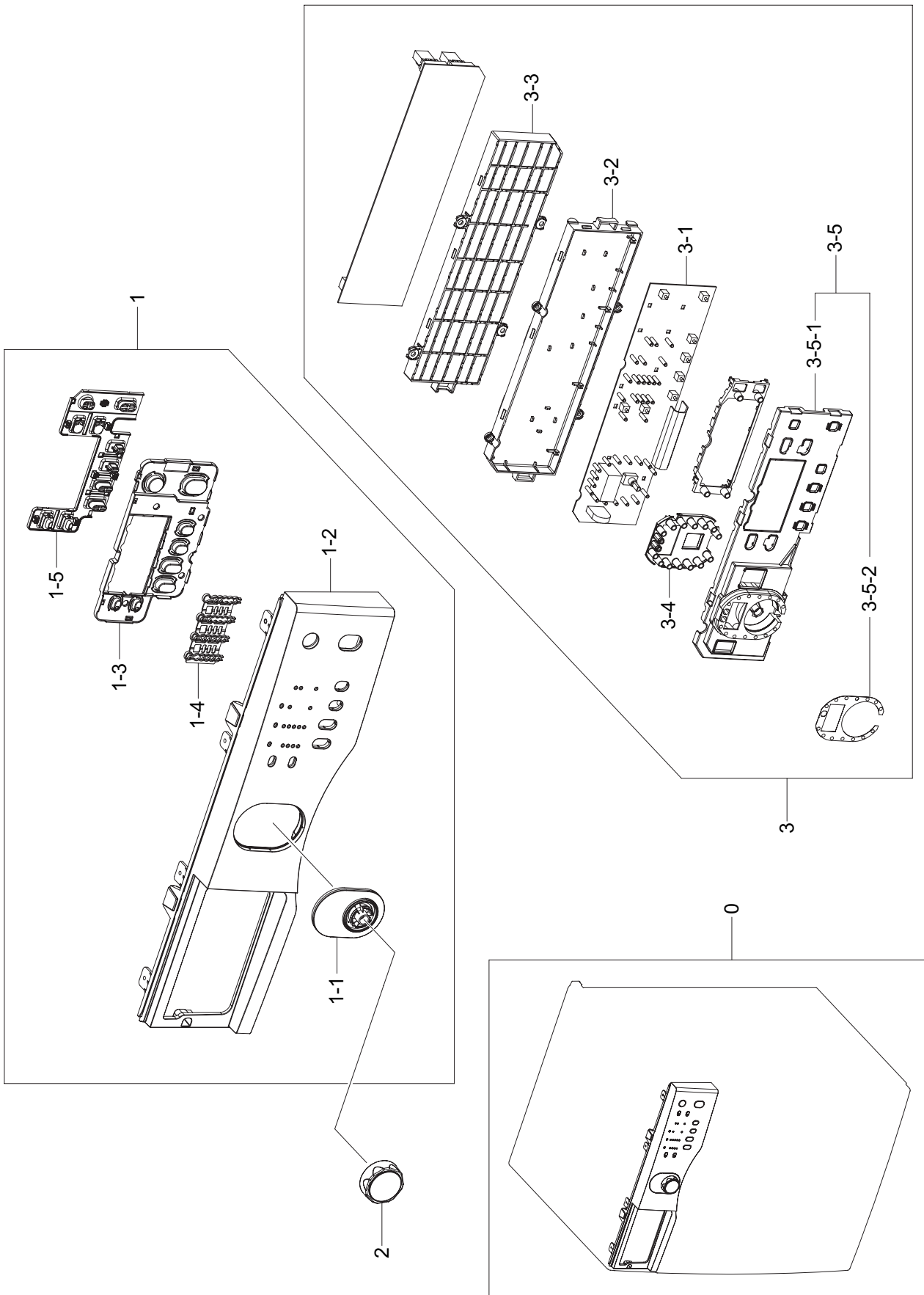

MODEL CODE: SDC14709/XEEService Bom (**SA**: SERVICE AVAILABLE, **SNA**: SERVICE NOT AVAILABLE)

Drawing No.	Code No.	Description	Specification	QTY	Un	SA/SNA
0		ASSY-PANEL CONTROL & KNOB ENCODER		1		
1	DC97-15853B	ASSY PANEL CONTROL	D100-PJT,SDC14709,DA WHT,GOOD	1	PC	SNA
1-1	DC64-01533A	WINDOW-ENCODER	HEBA,ABS,T2.0,-,-,-,BLK,HIGH/MID	1	PC	SNA
1-2	DC64-02008A	PANEL-CONTROL	SDC16809,ABS,W593.2,L52,WHT,BETTER	1	PC	SA
1-3	DC64-02009A	BUTTON-PUSH(F)	SDC16809,ABS,DA WHT,BETTER	1	PC	SA
1-4	DC64-02010A	DECORATION-LED	SDC16809,ABS,L6.8,TRP,BETTER	1	PC	SA
1-5	DC64-02011A	BUTTON-RUBBER	SDC16809,SILICON,TRP,HARDNESS45	1	PC	SA
2	DC97-14576B	ASSY KNOB ENCODER	WF8804SS,mid-DESIGN/8.0kg/ENG/Ag+,Airwash/Anti leakage,-,-	1	PC	SA
3	DC92-00397A	ASSY PCB MAIN	D100,D100 BETTER/GOOD,230V/50Hz,Y,SMPS,TNY277,9W	1	PC	SNA
3-1	DC41-00134A	PCB-MAIN	D100 BETTER,GOOD,FR-1,1,1.0,T1.6,W327*L197,Above 600V	1	PC	SA
3-2	DC61-01941A	GUIDE-PCB(S)	HEBA-PJT,ABS(V0),T2.0,-,-,WHT,HIGH/MID/ (UL94- 5VA GRADE)	1	PC	SNA
3-3	DC61-02342A	GUIDE-PCB(M)	GE24-DRYER,ABS+PC,T3.0,W97.1,L335.5,GRY,5VA GRADE	1	PC	SNA
3-4	DC64-01560A	DECORATION-LED	HEBA-PJT,ABS,T2.7,W50,L550,-,TRANSPARENCY,-	1	PC	SNA
3-5	DC97-14969C	ASSY COVER PCB	HEBA-PJT,COVER PCB(S) MID TYPE+PET,-,-,-,-	1	PC	SA
3-5-1	DC63-00861B	COVER-PCB(S)	HEBA-PJT,HIPS,T2.0,-,-,-,-,BLK,MID	1	PC	SNA
3-5-2	DC64-01607A	INLAY-ENCODER	HEBA,PET,T0.188,W22.2,L9.6,BLK,-	1	PC	SNA

5-4. ASS'Y DRUM & DRUM FRONT

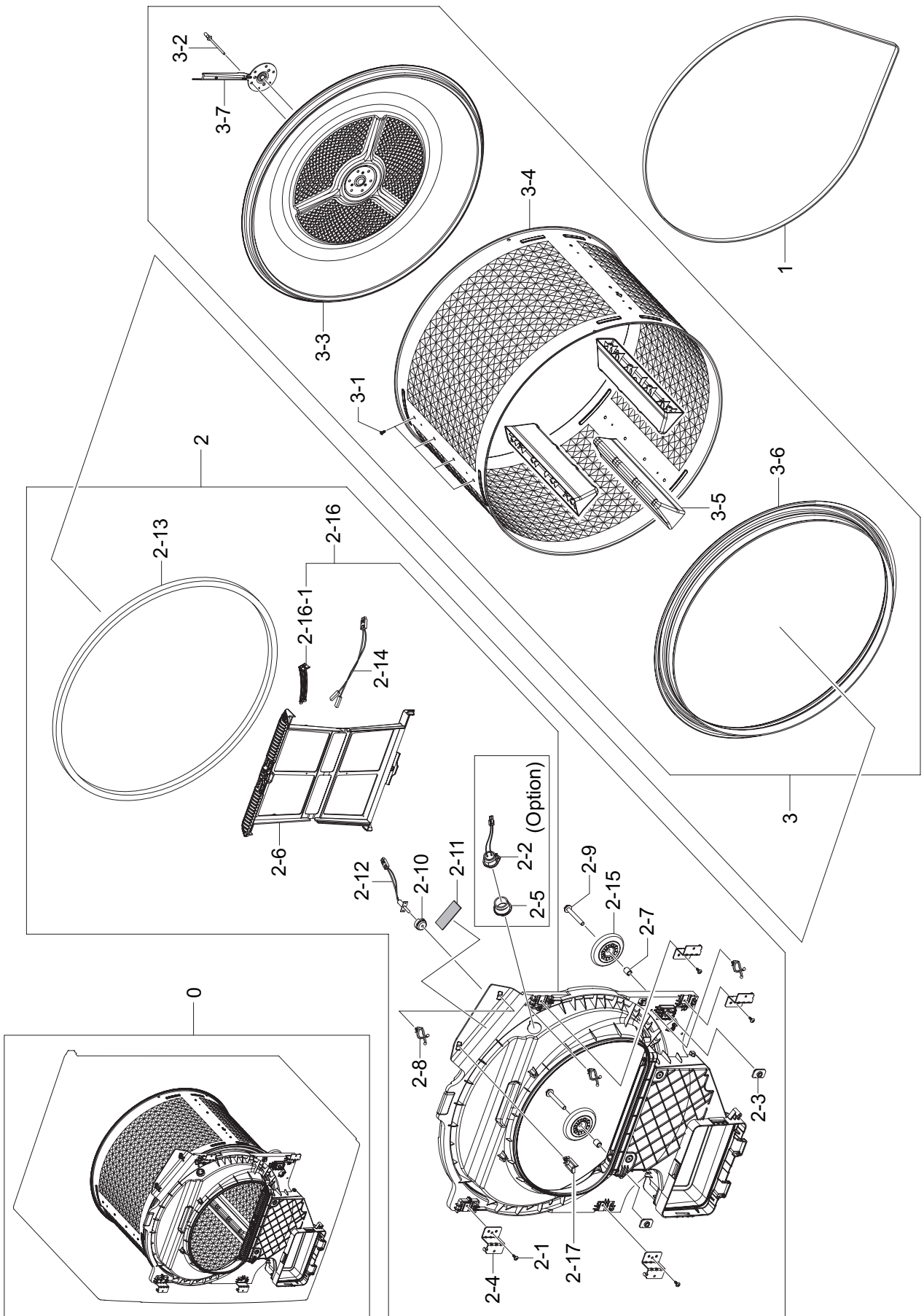

MODEL CODE: SDC18809/XEN

Service Bom (SA: SERVICE AVAILABLE, SNA: SERVICE NOT AVAILABLE)

Drawing No.	Code No.	Description	Specification	QTY	Un	SA/SNA
0		ASSY DRUM & ASSY DRUM FRONT(R)	D100-DRYER,SDC18809/XEN	1	PC	SNA
1	6602-002024	BELT-TIMING GEAR	7PH1970,RUBBER,T2.7,L1970,BLK	1	PC	SA
2	DC97-15758A	ASSY DRUM FRONT	D100 PJT,SDC18809,T2.5,W572	1	PC	SA
2-1	6002-001306	SCREW-TAPPING	TH,+,-,1,M4,L14,ZPC(WHT),SWRCH18A,-	4	PC	SNA
2-2	DC47-00027A	LAMP-ASSY LAMP	DRUM LIGHT,DRUM LIGHT,5mm,90mm,30mA,110mW,3.6V	1	PC	SA
2-3	DC61-00201A	BRACKET-NUT	P1291,SBHG-R,T3,NO-PAINT/MOTOR	2	PC	SA
2-4	DC61-01236A	BRACKET-DRUM FRONT	WINGS-DRYER,SGCC(HGI),T2.0,-,-,DRUM-FRONT	4	PC	SNA
2-5	DC61-02457A	FIXER-LAMP	D100-DRYER,EPDM,GRAY	1	PC	SA
2-6	DC61-02473A	CASE-FILTER	SDC18809,PP,GRY	1	PC	SA
2-7	DC61-02485A	BUSH-BEARING	SDC18809,SWRCH10A,ID8,OD12,L15,WHT,ZPC	2	PC	SA
2-8	DC61-40086A	HOLDER-WIRE	DAWH-3NB,NYLON66,-,-,-,NTR(PI15)	3	PC	SA
2-9	DC66-00572A	SHAFT ROLLER	SDC18809,SWRCH10A,L61,OD8,ZPC(WHT),M13/M8XP=1.25	2	PC	SA
2-10	DC69-01312A	PACKING-THERMISTOR	SDC18809,EPDM,EPDM,ID4.5,H13,GRY,HARDNESS 50,D100 PJT	1	PC	SA
2-11	DC72-00040H	SPONGE-HARNESS	SDC18809,PU-FOAM,T3.0,W50,L200,BLK,D100	1	PC	SA
2-12	DC90-10128G	ASSY THERMISTOR	SEW-745DW,L120,-,-	1	PC	SC
2-13	DC93-00125A	ASSY GASKET PAD	D100,DC18809,PE+WOL+SPONGE+TAPE,38g	1	PC	SA
2-14	DC96-00766A	ASSY WIRE HARNESS	GR-PJT,-,-,SUB/TOUCH SENSOR,-,-	1	PC	SA
2-15	DC97-15768A	ASSY ROLLER	D100-PJT,SDC18809	2	PC	SNA
2-16	DC97-15863A	ASSY DRUM FRONT-SUB	D100 PJT,SDC18809,T2.5,W572	1	PC	SA
2-16-1	DC61-02359A	PLATE-SENSOR	GE24-DRYER,STS430,T0.8,W105.2	2	PC	SA
2-17	DC61-00553B	HOLDER-WIRE	SADDLE -,NYLON66,-,-,-,NTR,DAWS-3NE	1	PC	SA
3	DC97-15812A	ASSY DRUM WRAPPER	D100-PJT,SDC-18809,591*459.8	1	PC	SNA
3-1	6002-000234	SCREW-TAPPING	TH,+,NO,2S,M4,L16,ZPC(WHT),SWRC H18A	12	PC	SNA
3-2	6041-001043	RIVET-RH	SXXP(00611),STS,OD4.8,L12.5,NTR	6	PC	SNA
3-3	DC66-00538A	DRUM-BACK	GE24-DRYER,STS430,-,OD571,T0.5,-,GE24-DRYER	1	PC	SNA
3-4	DC66-00539A	DRUM-WRAPPER	GE24-DRYER,STS430,-,OD572,T0.5,-,DIAMOND DRUM	1	PC	SNA
3-5	DC66-00541A	DRUM-LIFTER	GE24-DRYER,PP-FC2210,T3.0,GRAY(G246),GE24-DRYER	3	PC	SA
3-6	DC66-00600A	DRUM-FRONT	D100-DRYER,STAINLESS-STS430,OD571,T0.8	1	PC	SNA
3-7	DC97-15817A	ASSY FLANGE SHAFT	D100-PJT,SDC-18809	1	PC	SNA

MODEL CODE: SDC16809/XEF

Service Bom (SA: SERVICE AVAILABLE, SNA: SERVICE NOT AVAILABLE)

Drawing No.	Code No.	Description	Specification	QTY	Un	SA/SNA
0		ASSY DRUM & ASSY DRUM FRONT(R)	D100-DRYER,SDC18809/XEN	1	PC	SNA
1	6602-002024	BELT-TIMING GEAR	7PH1970,RUBBER,T2.7,L1970,BLK	1	PC	SA
2	DC97-15758B	ASSY DRUM FRONT	D100 PJT,SDC16809,T2.5,BETTER	1	PC	SA
2-1	6002-001306	SCREW-TAPPING	TH,+,-,1,M4,L14,ZPC(WHT),SWRCH18A,-	4	PC	SNA
2-3	DC61-00201A	BRACKET-NUT	P1291,SBHG-R,T3,NO-PAINT/MOTOR	2	PC	SA
2-4	DC61-01236A	BRACKET-DRUM FRONT	WINGS-DRYER,SGCC(HGI),T2.0,-,-,-,DRUM-FRONT	4	PC	SNA
2-6	DC61-02473A	CASE-FILTER	SDC18809,PP,GRY	1	PC	SA
2-7	DC61-02485A	BUSH-BEARING	SDC18809,SWRCH10A,ID8,OD12,L15,WHT,ZPC	2	PC	SA
2-8	DC61-40086A	HOLDER-WIRE	DAWH-3NB,NYLON66,-,-,-,NTR(PI15)	3	PC	SA
2-9	DC66-00572A	SHAFT ROLLER	SDC18809,SWRCH10A,L61,OD8,ZPC(WHT),M13/M8XP=1.25	2	PC	SA
2-10	DC69-01312A	PACKING-THERMISTOR	SDC18809,EPDM,EPDM,ID4.5,H13,GRY,HARDNESS 50,D100 PJT	1	PC	SA
2-11	DC72-00040H	SPONGE-HARNESS	SDC18809,PU-FOAM,T3.0,W50,L200,BLK,D100	1	PC	SA
2-12	DC90-10128G	ASSY THERMISTOR	SEW-745DW,L120,-,-	1	PC	SC
2-13	DC93-00125A	ASSY GASKET PAD	D100,DC18809,PE+WOOL+SPONGE+T APE,38g	1	PC	SA
2-14	DC96-00766A	ASSY WIRE HARNESS	GR-PJT,-,-,SUB/TOUCH SENSOR,-,-	1	PC	SA
2-15	DC97-15768A	ASSY ROLLER	D100-PJT,SDC18809	2	PC	SNA
2-16	DC97-15863B	ASSY DRUM FRONT-SUB	D100 PJT,SDC16809,T2.5,W572	1	PC	SA
2-16-1	DC61-02359A	PLATE-SENSOR	GE24-DRYER,STS430,T0.8,W105.2	2	PC	SA
2-17	DC61-00553B	HOLDER-WIRE	SADDLE -,NYLON66,-,-,-,NTR,DAWS-3NE	1	PC	SA
3	DC97-15812A	ASSY DRUM WRAPPER	D100-PJT,SDC-18809,591*459.8	1	PC	SNA
3-1	6002-000234	SCREW-TAPPING	TH,+,-,NO,2S,M4,L16,ZPC(WHT),SWRC H18A	12	PC	SNA
3-2	6041-001043	RIVET-RH	SXXP(00611),STS,OD4.8,L12.5,NTR	6	PC	SNA
3-3	DC66-00538A	DRUM-BACK	GE24-DRYER,STS430,-,OD571,T0.5,-,GE24-DRYER	1	PC	SNA
3-4	DC66-00539A	DRUM-WRAPPER	GE24-DRYER,STS430,-,OD572,T0.5,-,DIAMOND DRUM	1	PC	SNA
3-5	DC66-00541A	DRUM-LIFTER	GE24-DRYER,PP-FC2210,T3.0,GRAY(G246),GE24-DRYER	3	PC	SA
3-6	DC66-00600A	DRUM-FRONT	D100-DRYER,STAINLESS-STS430,OD571,T0.8	1	PC	SNA
3-7	DC97-15817A	ASSY FLANGE SHAFT	D100-PJT,SDC-18809	1	PC	SNA

MODEL CODE: SDC14709/XEE

Service Bom (SA: SERVICE AVAILABLE, SNA: SERVICE NOT AVAILABLE)

Drawing No.	Code No.	Description	Specification	QTY	Un	SA/SNA
0		ASSY DRUM & ASSY DRUM FRONT(R)	D100-DRYER,SDC18809/XEN	1	PC	SNA
1	6602-002024	BELT-TIMING GEAR	7PH1970,RUBBER,T2.7,L1970,BLK	1	PC	SA
2	DC97-15758B	ASSY DRUM FRONT	D100 PJT,SDC16809,T2.5,BETTER	1	PC	SA
2-1	6002-001306	SCREW-TAPPING	TH,+,-,1,M4,L14,ZPC(WHT),SWRCH18A,-	4	PC	SNA
2-3	DC61-00201A	BRACKET-NUT	P1291,SBHG-R,T3,NO-PAINT/MOTOR	2	PC	SA
2-4	DC61-01236A	BRACKET-DRUM FRONT	WINGS-DRYER,SGCC(HGI),T2.0,-,-,-,DRUM-FRONT	4	PC	SNA
2-6	DC61-02473A	CASE-FILTER	SDC18809,PP,GRY	1	PC	SA
2-7	DC61-02485A	BUSH-BEARING	SDC18809,SWRCH10A,ID8,OD12,L15,WHT,ZPC	2	PC	SA
2-8	DC61-40086A	HOLDER-WIRE	DAWH-3NB,NYLON66,-,-,-,NTR(PI15)	3	PC	SA
2-9	DC66-00572A	SHAFT ROLLER	SDC18809,SWRCH10A,L61,OD8,ZPC(WHT),M13/M8XP=1.25	2	PC	SA
2-10	DC69-01312A	PACKING-THERMISTOR	SDC18809,EPDM,EPDM,ID4.5,H13,GRY,HARDNESS 50,D100 PJT	1	PC	SA
2-11	DC72-00040H	SPONGE-HARNESS	SDC18809,PU-FOAM,T3.0,W50,L200,BLK,D100	1	PC	SA
2-12	DC90-10128G	ASSY THERMISTOR	SEW-745DW,L120,-,-	1	PC	SC
2-13	DC93-00125A	ASSY GASKET PAD	D100,DC18809,PE+WOOL+SPONGE+T APE,38g	1	PC	SA
2-14	DC96-00766A	ASSY WIRE HARNESS	GR-PJT,-,-,SUB/TOUCH SENSOR,-,-	1	PC	SA
2-15	DC97-15768A	ASSY ROLLER	D100-PJT,SDC18809	2	PC	SNA
2-16	DC97-15863B	ASSY DRUM FRONT-SUB	D100 PJT,SDC16809,T2.5,W572	1	PC	SA
2-16-1	DC61-02359A	PLATE-SENSOR	GE24-DRYER,STS430,T0.8,W105.2	2	PC	SA
2-17	DC61-00553B	HOLDER-WIRE	SADDLE -,NYLON66,-,-,-,NTR,DAWS-3NE	1	PC	SA
3	DC97-15812B	ASSY DRUM WRAPPER	D100-PJT,SDC-18809,591*459.8	1	PC	SNA
3-1	6002-000234	SCREW-TAPPING	TH,+,-,NO,2S,M4,L16,ZPC(WHT),SWRC H18A	12	PC	SNA
3-2	6041-001043	RIVET-RH	SXXP(00611),STS,OD4.8,L12.5,NTR	6	PC	SNA
3-3	DC66-00538B	DRUM-BACK	D100-DRYER,ALCOT,OD571,T0.5,D100	1	PC	SNA
3-4	DC66-00539B	DRUM-WRAPPER	D100,ALCOT,OD572,T0.5,DIAMOND DRUM	1	PC	SNA
3-5	DC66-00541A	DRUM-LIFTER	GE24-DRYER,PP-FC2210,T3.0,GRAY(G246),GE24-DRYER	3	PC	SA
3-6	DC66-00600A	DRUM-FRONT	D100-DRYER,STAINLESS-STS430,OD571,T0.8	1	PC	SNA
3-7	DC97-15817A	ASSY FLANGE SHAFT	D100-PJT,SDC-18809	1	PC	SNA

5-5. ASS'Y CONDENSER

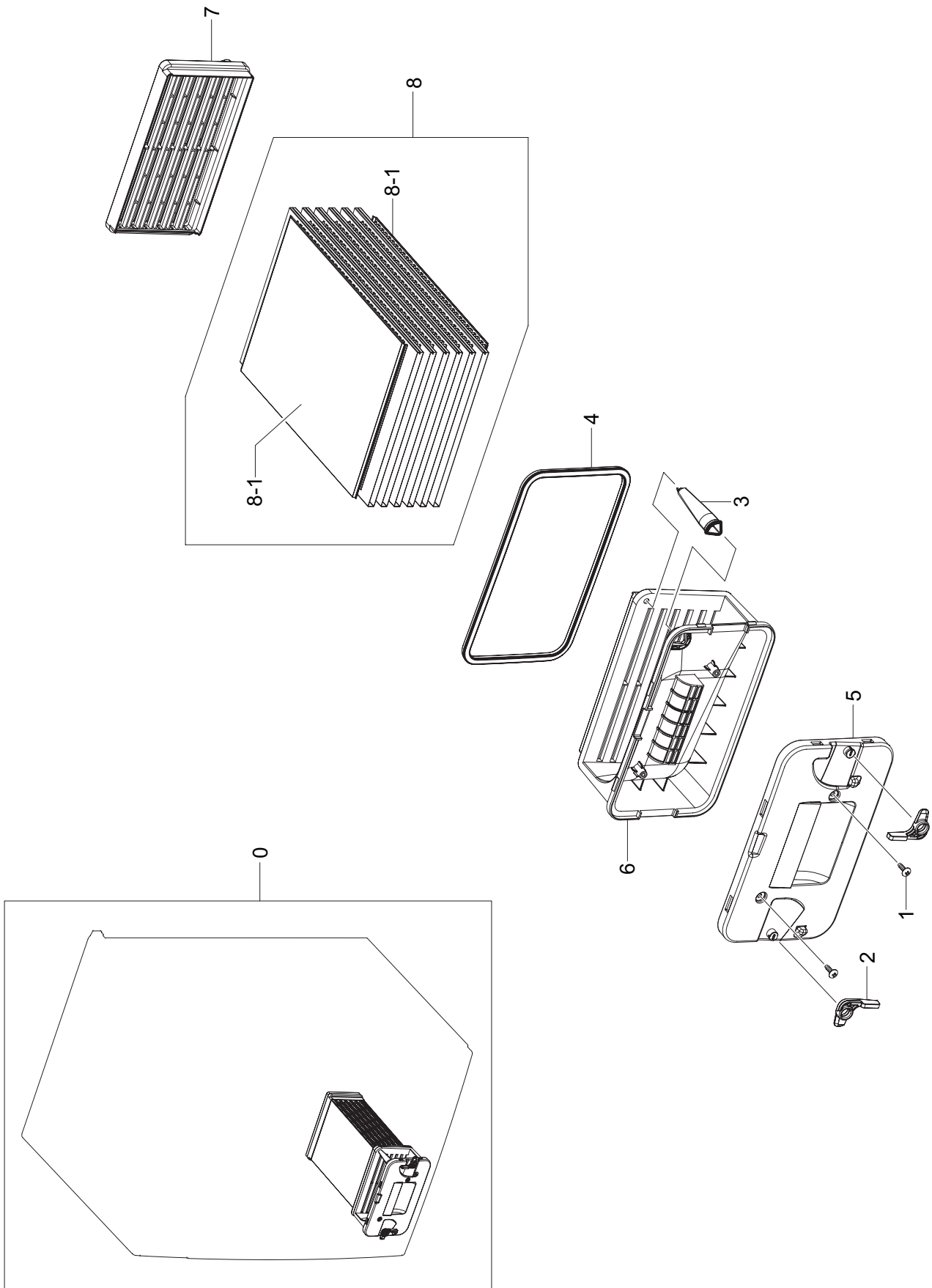

MODEL CODE: SDC18809/XENService Bom (**SA**: SERVICE AVAILABLE, **SNA**: SERVICE NOT AVAILABLE)

Drawing No.	Code No.	Description	Specification	QTY	Un	SA/SNA
0	DC93-00115A	ASSY CONDENSER	D100,SDC-18809	1	PC	SNA
1	6002-000444	SCREW-TAPPING	TH,+2,M4,L14,PASS,STS430	2	PC	SNA
2	DC61-02463A	FIXER-CONDENSER	SDC18809,PP,SKY BLUE,D100 PJT	2	PC	SNA
3	DC61-02494A	GUIDE-CONDENSER(M)	SDC-18809,PP,T2.0,L76.5,D100-PJT	1	PC	SNA
4	DC62-00280A	SEAL-CONDENSER	SDC18809,TPE,GRY,W222,L135,D100 PJT	1	PC	SA
5	DC63-01085A	COVER-CONDENSER	SDC18809,PP,W225.7,L135.3,GRY,D100-PJT	1	PC	SNA
6	DC63-01094A	COVER-CONDENSER(M)	SDC18809,PP,W221,L116,D100-PJT	1	PC	SNA
7	DC63-01099A	COVER-CONDENSER(B)	SDC18809,PP,W190,L99,GRY,D100-PJT	1	PC	SNA
8	DC93-00166A	ASSY CONDENSER-SUB	D100,SDC-18809,AL,175x273x99	1	PC	SNA
8-1	DC61-02493A	PLATE-CONDENSER	SDC-18809,AL,T0.4,W245,L175,D100-PJT	2	PC	SNA

MODEL CODE: SDC16809/XEFService Bom (**SA**: SERVICE AVAILABLE, **SNA**: SERVICE NOT AVAILABLE)

Drawing No.	Code No.	Description	Specification	QTY	Un	SA/SNA
0	DC93-00115A	ASSY CONDENSER	D100,SDC-18809	1	PC	SNA
1	6002-000444	SCREW-TAPPING	TH,+,2,M4,L14,PASS,STS430	2	PC	SNA
2	DC61-02463A	FIXER-CONDENSER	SDC18809,PP,SKY BLUE,D100 PJT	2	PC	SNA
3	DC61-02494A	GUIDE-CONDENSER(M)	SDC-18809,PP,T2.0,L76.5,D100-PJT	1	PC	SNA
4	DC62-00280A	SEAL-CONDENSER	SDC18809,TPE,GRY,W222,L135,D100 PJT	1	PC	SA
5	DC63-01085A	COVER-CONDENSER	SDC18809,PP,W225.7,L135.3,GRY,D100-PJT	1	PC	SNA
6	DC63-01094A	COVER-CONDENSER(M)	SDC18809,PP,W221,L116,D100-PJT	1	PC	SNA
7	DC63-01099A	COVER-CONDENSER(B)	SDC18809,PP,W190,L99,GRY,D100-PJT	1	PC	SNA
8	DC93-00166A	ASSY CONDENSER-SUB	D100,SDC-18809,AL,175x273x99	1	PC	SNA
8-1	DC61-02493A	PLATE-CONDENSER	SDC-18809,AL,T0.4,W245,L175,D100-PJT	2	PC	SNA

MODEL CODE: SDC14709/XEEService Bom (**SA**: SERVICE AVAILABLE, **SNA**: SERVICE NOT AVAILABLE)

Drawing No.	Code No.	Description	Specification	QTY	Un	SA/SNA
0	DC93-00115A	ASSY CONDENSER	D100,SDC-18809	1	PC	SNA
1	6002-000444	SCREW-TAPPING	TH,+,2,M4,L14,PASS,STS430	2	PC	SNA
2	DC61-02463A	FIXER-CONDENSER	SDC18809,PP,SKY BLUE,D100 PJT	2	PC	SNA
3	DC61-02494A	GUIDE-CONDENSER(M)	SDC-18809,PP,T2.0,L76.5,D100-PJT	1	PC	SNA
4	DC62-00280A	SEAL-CONDENSER	SDC18809,TPE,GRY,W222,L135,D100 PJT	1	PC	SA
5	DC63-01085A	COVER-CONDENSER	SDC18809,PP,W225.7,L135.3,GRY,D100-PJT	1	PC	SNA
6	DC63-01094A	COVER-CONDENSER(M)	SDC18809,PP,W221,L116,D100-PJT	1	PC	SNA
7	DC63-01099A	COVER-CONDENSER(B)	SDC18809,PP,W190,L99,GRY,D100-PJT	1	PC	SNA
8	DC93-00166A	ASSY CONDENSER-SUB	D100,SDC-18809,AL,175x273x99	1	PC	SNA
8-1	DC61-02493A	PLATE-CONDENSER	SDC-18809,AL,T0.4,W245,L175,D100-PJT	2	PC	SNA

5-6. ASS'Y DRAWER & HOUSING DRAWER

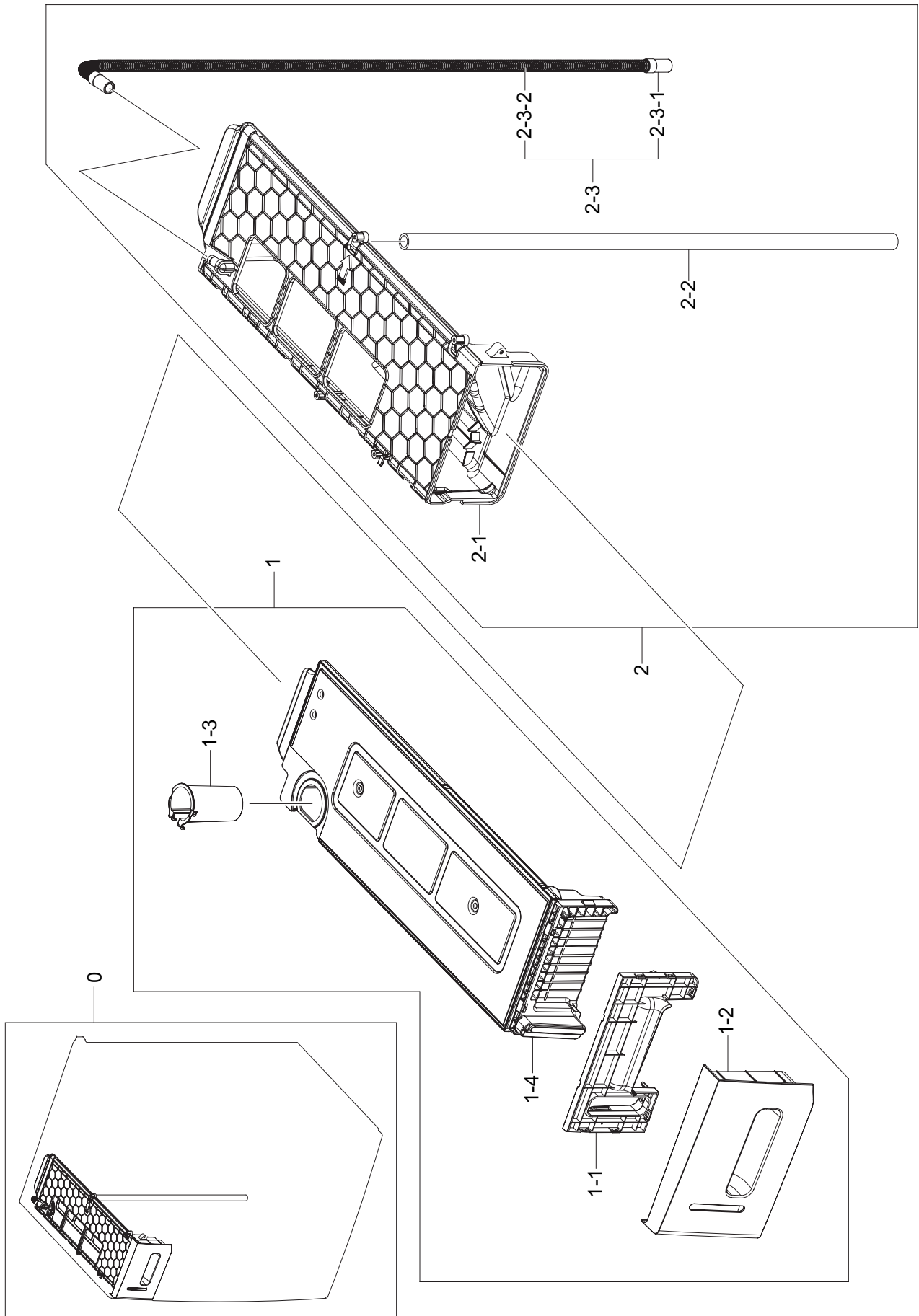

MODEL CODE: SDC18809/XENService Bom (**SA**: SERVICE AVAILABLE, **SNA**: SERVICE NOT AVAILABLE)

Drawing No.	Code No.	Description	Specification	QTY	Un	SA/SNA
0		ASSY DRAWER & HOUSING DRAWER		1		
1	DC97-15763A	ASSY DRAWER	D100-PJT,SDC18809	1	PC	SNA
1-1	DC64-02006A	HANDLE-DRAWER	SDC18809,ABS,W202,L107.8,DA-WHT(HG0760GP)	1	PC	SA
1-2	DC64-02007A	PANEL-DRAWER	SDC18809,ABS,W184,L113.5,DA-WHT	1	PC	SA
1-3	DC67-00428A	CAP-TANK WATER	SDC18809,PP,SKY BLUE	1	PC	SA
1-4	DC97-15927A	ASSY DRAWER-SUB	D100 PJT,SDC18809,PP,H89.1	1	PC	SNA
2	DC97-15938A	ASSY HOUSING DRAWER	D100 PJT,SDC18809,PP,L562	1	PC	SNA
2-1	DC61-02476A	HOUSING-DRAWER	SDC18809,PP,NTR	1	PC	SA
2-2	DC67-00429A	HOSE-WATER	SDC18809,EPDM,ID13.0,OD18.0,T2.5,L680,BLK,OVER-FLOW	1	PC	SA
2-3	DC97-15757A	ASSY HOSE DRAIN	D100,SDC18809,L748,GRY	1	PC	SA
2-3-1	DC61-02469A	BUSH-HOSE	SDC18809,EPDM+PP,ID9.6,OD15.5,L32,GRY	2	PC	SNA
2-3-2	DC67-00424A	HOSE-DRAIN	SDC18809,PP,ID8,OD13,T0.4,L700,GRY	1	PC	SA

MODEL CODE: SDC16809/XEFService Bom (**SA**: SERVICE AVAILABLE, **SNA**: SERVICE NOT AVAILABLE)

Drawing No.	Code No.	Description	Specification	QTY	Un	SA/SNA
0		ASSY DRAWER & HOUSING DRAWER		1		
1	DC97-15763A	ASSY DRAWER	D100-PJT,SDC18809	1	PC	SNA
1-1	DC64-02006A	HANDLE-DRAWER	SDC18809,ABS,W202,L107.8,DA-WHT(HG0760GP)	1	PC	SA
1-2	DC64-02007A	PANEL-DRAWER	SDC18809,ABS,W184,L113.5,DA-WHT	1	PC	SA
1-3	DC67-00428A	CAP-TANK WATER	SDC18809,PP,SKY BLUE	1	PC	SA
1-4	DC97-15927A	ASSY DRAWER-SUB	D100 PJT,SDC18809,PP,H89.1	1	PC	SNA
2	DC97-15938A	ASSY HOUSING DRAWER	D100 PJT,SDC18809,PP,L562	1	PC	SNA
2-1	DC61-02476A	HOUSING-DRAWER	SDC18809,PP,NTR	1	PC	SA
2-2	DC67-00429A	HOSE-WATER	SDC18809,EPDM,ID13.0,OD18.0,T2.5,L680,BLK,OVER-FLOW	1	PC	SA
2-3	DC97-15757A	ASSY HOSE DRAIN	D100,SDC18809,L748,GRY	1	PC	SA
2-3-1	DC61-02469A	BUSH-HOSE	SDC18809,EPDM+PP,ID9.6,OD15.5,L32,GRY	2	PC	SNA
2-3-2	DC67-00424A	HOSE-DRAIN	SDC18809,PP,ID8,OD13,T0.4,L700,GRY	1	PC	SA

MODEL CODE: SDC14709/XEEService Bom (**SA**: SERVICE AVAILABLE, **SNA**: SERVICE NOT AVAILABLE)

Drawing No.	Code No.	Description	Specification	QTY	Un	SA/SNA
0		ASSY DRAWER & HOUSING DRAWER		1		
1	DC97-15763A	ASSY DRAWER	D100-PJT,SDC18809	1	PC	SNA
1-1	DC64-02006A	HANDLE-DRAWER	SDC18809,ABS,W202,L107.8,DA-WHT(HG0760GP)	1	PC	SA
1-2	DC64-02007A	PANEL-DRAWER	SDC18809,ABS,W184,L113.5,DA-WHT	1	PC	SA
1-3	DC67-00428A	CAP-TANK WATER	SDC18809,PP,SKY BLUE	1	PC	SA
1-4	DC97-15927A	ASSY DRAWER-SUB	D100 PJT,SDC18809,PP,H89.1	1	PC	SNA
2	DC97-15938A	ASSY HOUSING DRAWER	D100 PJT,SDC18809,PP,L562	1	PC	SNA
2-1	DC61-02476A	HOUSING-DRAWER	SDC18809,PP,NTR	1	PC	SA
2-2	DC67-00429A	HOSE-WATER	SDC18809,EPDM,ID13.0,OD18.0,T2.5,L680,BLK,OVER-FLOW	1	PC	SA
2-3	DC97-15757A	ASSY HOSE DRAIN	D100,SDC18809,L748,GRY	1	PC	SA
2-3-1	DC61-02469A	BUSH-HOSE	SDC18809,EPDM+PP,ID9.6,OD15.5,L32,GRY	2	PC	SNA
2-3-2	DC67-00424A	HOSE-DRAIN	SDC18809,PP,ID8,OD13,T0.4,L700,GRY	1	PC	SA

5-7. ASS'Y BASE

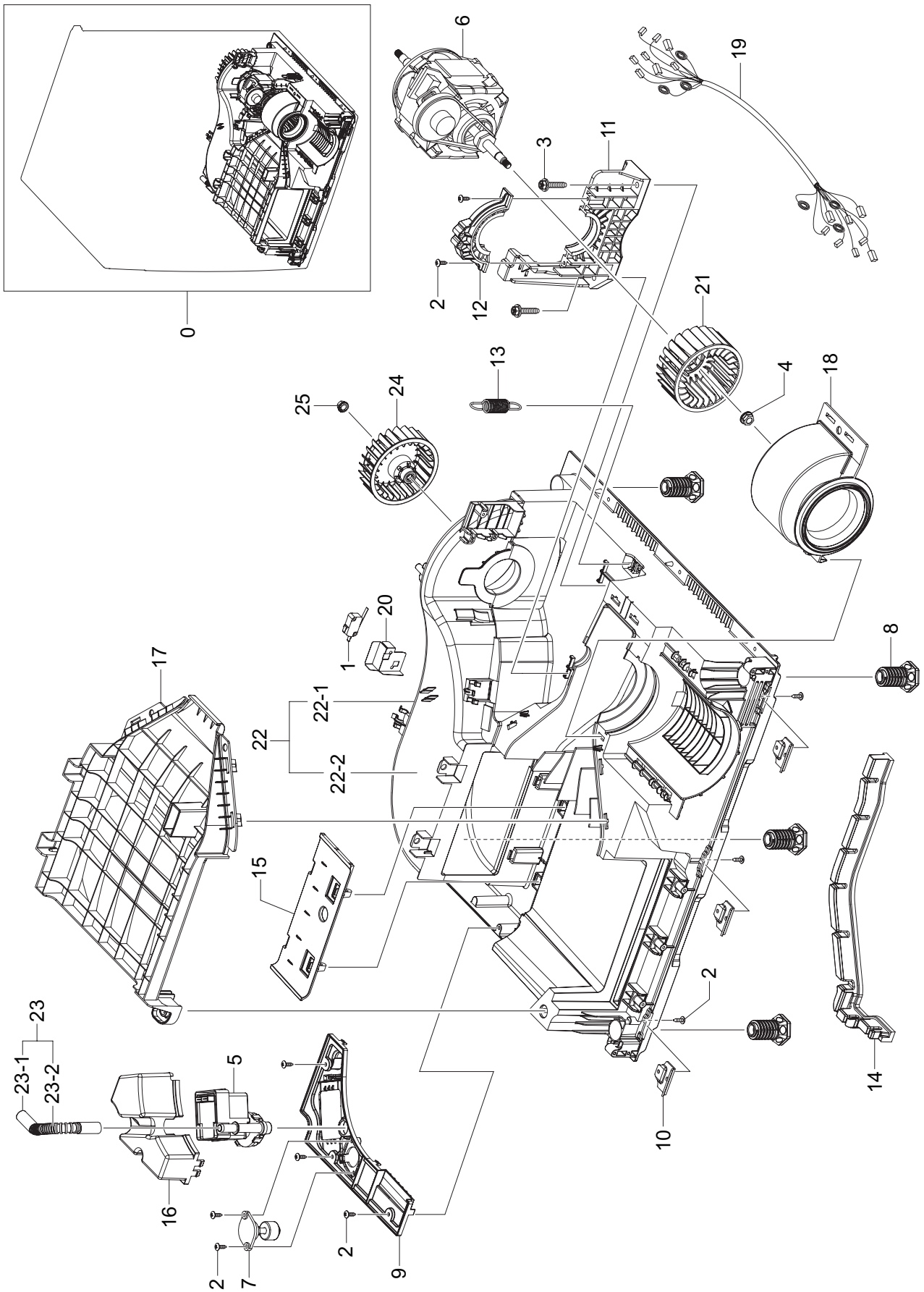

MODEL CODE: SDC18809/XEN

Service Bom (SA: SERVICE AVAILABLE, SNA: SERVICE NOT AVAILABLE)

Drawing No.	Code No.	Description	Specification	QTY	Un	SA/SNA
0	DC90-02691A	ASSY BASE	D100-PJT,SDC-18809	1	PC	SNA
1	3405-001077	SWITCH-MICRO	125V,15A,180gf,2	1	PC	SA
2	6002-001306	SCREW-TAPPING	TH,+,-,1,M4,L14,ZPC(WHT),SWRCH18A,-	3	PC	SNA
2	6002-001306	SCREW-TAPPING	TH,+,-,1,M4,L14,ZPC(WHT),SWRCH18A,-	2	PC	SNA
2	6002-001306	SCREW-TAPPING	TH,+,-,1,M4,L14,ZPC(WHT),SWRCH18A,-	1	PC	SNA
2	6002-001306	SCREW-TAPPING	TH,+,-,1,M4,L14,ZPC(WHT),SWRCH18A,-	1	PC	SNA
2	6002-001306	SCREW-TAPPING	TH,+,-,1,M4,L14,ZPC(WHT),SWRCH18A,-	2	PC	SNA
2	6002-001306	SCREW-TAPPING	TH,+,-,1,M4,L14,ZPC(WHT),SWRCH18A,-	2	PC	SNA
3	6002-001313	SCREW-HEX	HWH,+,-,M6.5,L25,ZPC(WHT),SWRCH18 A,2,SERATION	2	PC	SA
4	6021-001201	NUT-INCH	LEFT TURN,3/8"-24,ZPC(YEL),MSWR10,INCH	1	PC	SA
5	DC31-00105A	PUMP-DRAIN	B13-6AA01120,220V-240V,50Hz,44.8*72.5*82.1,13W	1	PC	SA
6	DC31-00106A	MOTOR INDUCTION-DRYER	Y6S258D04,2,220V-240V,50Hz,1.4,300,2700,Condensing Type	1	PC	SNA
7	DC34-00010A	SWITCH FLOAT	FS-3B-02,1,2,POM,Float Switch,5V	1	PC	SA
8	DC61-02447A	LEG	GE24-DRYER,ABS+PC,GRY,L49.3	4	PC	SA
9	DC61-02459A	HOLDER-PUMP MOTOR	SDC18809,PP,W259,L145,NTR,D100-PJT	1	PC	SNA
10	DC61-02465A	GUIDE-FRAME FRONT	D100_PJT,GI,T2.0,W38,L35.8	3	PC	SNA
11	DC61-02466A	SUPPORT-MOTOR(L)	D100-PJT,PP,T3.0,W169.1,L113,106g	1	PC	SNA
12	DC61-02467A	SUPPORT-MOTOR(U)	D100-PJT,PP,T3.0,W111,L58.3,19g	1	PC	SNA
13	DC61-02487A	SPRING ETC-TENSION	SDC18809,HSWR,CD1.8,OD15,L70,TUR NS21.75,NTR,D100-PJT	1	PC	SNA
14	DC62-00290A	SEAL-BASE	SDC18809,EPP,NTR,T30,W18.2,L324.8,D100	1	PC	SA
15	DC63-01083A	COVER-BASE	SDC18809,PP,W250,L93,NTR,D100-PJT	1	PC	SNA
16	DC63-01084A	COVER-PUMP	SDC18809,ABS+PC,W137,L111,NTR,D100-PJT	1	PC	SNA
17	DC63-01087A	COVER-CONDENSER(U)	D100_DRYER,PP,W284.6,L352,NTR	1	PC	SNA
18	DC63-01090A	COVER-FAN(C)	SDC18809,PP,W175,L99,NTR,D100-PJT	1	PC	SNA
19	DC93-00097A	ASSY M. WIRE HARNESS	D100,SDC18809,AC230V,CONDENSING DRYER	1	PC	SNA
20	DC63-01155A	COVER-SWITCH(M)	SDC18809,STS430,T0.4,W34,W33	1	PC	SNA
21	DC67-00425A	FAN-(C)	D100-DRYER,FRPP,OD100,GF15%	1	PC	SNA
22	DC90-02991A	ASSY BASE-SUB	D100-PJT,SDC-18809	1	PC	SNA
22-1	DC61-02478A	BASE	SDC18809,PP,W592,L531.3,NTR	1	PC	SA
22-2	DC63-01088A	COVER-FAN(P)	SDC18809,PP,W502,L144,NTR,D100-PJT	1	PC	SNA
23	DC97-15757B	ASSY HOSE DRAIN	D100,SDC18809,SINGLE BUSH HOSE,L211,GRY	1	PC	SA
23-1	DC61-02469A	BUSH-HOSE	SDC18809,EPDM+PP,ID9.6,OD15.5,L32,GRY	2	PC	SNA
23-2	DC67-00424B	HOSE-DRAIN	SDC18809,PP,ID8,OD13,T0.4,L163,GRY	1	PC	SA
24	DC67-00426A	FAN-(P)	D100-DRYER,FRPP,OD139,GF15%	1	PC	SNA
25	6021-001321	NUT-INCH	RIGHT TURN,3/8"-24,ZPC(BLK),SWCH 10AK	1	PC	SNA

MODEL CODE: SDC16809/XEF

Service Bom (SA: SERVICE AVAILABLE, SNA: SERVICE NOT AVAILABLE)

Drawing No.	Code No.	Description	Specification	QTY	Un	SA/SNA
0	DC90-02691B	ASSY BASE	D100-PJT,SDC-16809	1	PC	SNA
1	3405-001077	SWITCH-MICRO	125V,15A,180gf,2	1	PC	SA
2	6002-001306	SCREW-TAPPING	TH,+,-,1,M4,L14,ZPC(WHT),SWRCH18A,-	3	PC	SNA
2	6002-001306	SCREW-TAPPING	TH,+,-,1,M4,L14,ZPC(WHT),SWRCH18A,-	2	PC	SNA
2	6002-001306	SCREW-TAPPING	TH,+,-,1,M4,L14,ZPC(WHT),SWRCH18A,-	1	PC	SNA
2	6002-001306	SCREW-TAPPING	TH,+,-,1,M4,L14,ZPC(WHT),SWRCH18A,-	1	PC	SNA
2	6002-001306	SCREW-TAPPING	TH,+,-,1,M4,L14,ZPC(WHT),SWRCH18A,-	2	PC	SNA
2	6002-001306	SCREW-TAPPING	TH,+,-,1,M4,L14,ZPC(WHT),SWRCH18A,-	2	PC	SNA
3	6002-001313	SCREW-HEX	HWH,+,-,M6.5,L25,ZPC(WHT),SWRCH18 A,2,SERATION	2	PC	SA
4	6021-001201	NUT-INCH	LEFT TURN,3/8"-24,ZPC(YEL),MSWR10,INCH	1	PC	SA
5	DC31-00105A	PUMP-DRAIN	B13-6AA01120,220V-240V,50Hz,44.8*72.5*82.1,13W	1	PC	SA
6	DC31-00106A	MOTOR INDUCTION-DRYER	Y6S258D04,2,220V-240V,50Hz,1.4,300,2700,Condensing Type	1	PC	SNA
7	DC34-00010A	SWITCH FLOAT	FS-3B-02,1,2,POM,Float Switch,5V	1	PC	SA
8	DC61-02447A	LEG	GE24-DRYER,ABS+PC,GRY,L49.3	4	PC	SA
9	DC61-02459A	HOLDER-PUMP MOTOR	SDC18809,PP,W259,L145,NTR,D100-PJT	1	PC	SNA
10	DC61-02465A	GUIDE-FRAME FRONT	D100_PJT,GI,T2.0,W38,L35.8	3	PC	SNA
11	DC61-02466A	SUPPORT-MOTOR(L)	D100-PJT,PP,T3.0,W169.1,L113,106g	1	PC	SNA
12	DC61-02467A	SUPPORT-MOTOR(U)	D100-PJT,PP,T3.0,W111,L58.3,19g	1	PC	SNA
13	DC61-02487A	SPRING ETC-TENSION	SDC18809,HSWR,CD1.8,OD15,L70,TUR NS21.75,NTR,D100-PJT	1	PC	SNA
14	DC62-00290A	SEAL-BASE	SDC18809,EPP,NTR,T30,W18.2,L324.8,D100	1	PC	SA
15	DC63-01083A	COVER-BASE	SDC18809,PP,W250,L93,NTR,D100-PJT	1	PC	SNA
16	DC63-01084A	COVER-PUMP	SDC18809,ABS+PC,W137,L111,NTR,D100-PJT	1	PC	SNA
17	DC63-01087A	COVER-CONDENSER(U)	D100_DRYER,PP,W284.6,L352,NTR	1	PC	SNA
18	DC63-01090A	COVER-FAN(C)	SDC18809,PP,W175,L99,NTR,D100-PJT	1	PC	SNA
19	DC93-00097A	ASSY M. WIRE HARNESS	D100,SDC18809,AC230V,CONDENSING DRYER	1	PC	SNA
20	DC63-01155A	COVER-SWITCH(M)	SDC18809,STS430,T0.4,W34,W33	1	PC	SNA
21	DC67-00425A	FAN-(C)	D100-DRYER,FRPP,OD100,GF15%	1	PC	SNA
22	DC90-02991A	ASSY BASE-SUB	D100-PJT,SDC-18809	1	PC	SNA
22-1	DC61-02478A	BASE	SDC18809,PP,W592,L531.3,NTR	1	PC	SA
22-2	DC63-01088A	COVER-FAN(P)	SDC18809,PP,W502,L144,NTR,D100-PJT	1	PC	SNA
23	DC97-15757B	ASSY HOSE DRAIN	D100,SDC18809,SINGLE BUSH HOSE,L211,GRY	1	PC	SA
23-1	DC61-02469A	BUSH-HOSE	SDC18809,EPDM+PP,ID9.6,OD15.5,L32,GRY	2	PC	SNA
23-2	DC67-00424B	HOSE-DRAIN	SDC18809,PP,ID8,OD13,T0.4,L163,GRY	1	PC	SA
24	DC67-00426A	FAN-(P)	D100-DRYER,FRPP,OD139,GF15%	1	PC	SNA
25	6021-001321	NUT-INCH	RIGHT TURN,3/8"-24,ZPC(BLK),SWCH 10AK	1	PC	SNA

MODEL CODE: SDC14709/XEE

Service Bom (SA: SERVICE AVAILABLE, SNA: SERVICE NOT AVAILABLE)

Drawing No.	Code No.	Description	Specification	QTY	Un	SA/SNA
0	DC90-02691B	ASSY BASE	D100-PJT,SDC-16809	1	PC	SNA
1	3405-001077	SWITCH-MICRO	125V,15A,180gf,2	1	PC	SA
2	6002-001306	SCREW-TAPPING	TH,+,-,1,M4,L14,ZPC(WHT),SWRCH18A,-	3	PC	SNA
2	6002-001306	SCREW-TAPPING	TH,+,-,1,M4,L14,ZPC(WHT),SWRCH18A,-	2	PC	SNA
2	6002-001306	SCREW-TAPPING	TH,+,-,1,M4,L14,ZPC(WHT),SWRCH18A,-	1	PC	SNA
2	6002-001306	SCREW-TAPPING	TH,+,-,1,M4,L14,ZPC(WHT),SWRCH18A,-	1	PC	SNA
2	6002-001306	SCREW-TAPPING	TH,+,-,1,M4,L14,ZPC(WHT),SWRCH18A,-	2	PC	SNA
2	6002-001306	SCREW-TAPPING	TH,+,-,1,M4,L14,ZPC(WHT),SWRCH18A,-	2	PC	SNA
3	6002-001313	SCREW-HEX	HWH,+,-,M6.5,L25,ZPC(WHT),SWRCH18 A,2,SERATION	2	PC	SA
4	6021-001201	NUT-INCH	LEFT TURN,3/8"-24,ZPC(YEL),MSWR10,INCH	1	PC	SA
5	DC31-00105A	PUMP-DRAIN	B13-6AA01120,220V-240V,50Hz,44.8*72.5*82.1,13W	1	PC	SA
6	DC31-00106A	MOTOR INDUCTION-DRYER	Y6S258D04,2,220V-240V,50Hz,1.4,300,2700,Condensing Type	1	PC	SNA
7	DC34-00010A	SWITCH FLOAT	FS-3B-02,1,2,POM,Float Switch,5V	1	PC	SA
8	DC61-02447A	LEG	GE24-DRYER,ABS+PC,GRY,L49.3	4	PC	SA
9	DC61-02459A	HOLDER-PUMP MOTOR	SDC18809,PP,W259,L145,NTR,D100-PJT	1	PC	SNA
10	DC61-02465A	GUIDE-FRAME FRONT	D100_PJT,GI,T2.0,W38,L35.8	3	PC	SNA
11	DC61-02466A	SUPPORT-MOTOR(L)	D100-PJT,PP,T3.0,W169.1,L113,106g	1	PC	SNA
12	DC61-02467A	SUPPORT-MOTOR(U)	D100-PJT,PP,T3.0,W111,L58.3,19g	1	PC	SNA
13	DC61-02487A	SPRING ETC-TENSION	SDC18809,HSWR,CD1.8,OD15,L70,TUR NS21.75,NTR,D100-PJT	1	PC	SNA
14	DC62-00290A	SEAL-BASE	SDC18809,EPP,NTR,T30,W18.2,L324.8,D100	1	PC	SA
15	DC63-01083A	COVER-BASE	SDC18809,PP,W250,L93,NTR,D100-PJT	1	PC	SNA
16	DC63-01084A	COVER-PUMP	SDC18809,ABS+PC,W137,L111,NTR,D100-PJT	1	PC	SNA
17	DC63-01087A	COVER-CONDENSER(U)	D100_DRYER,PP,W284.6,L352,NTR	1	PC	SNA
18	DC63-01090A	COVER-FAN(C)	SDC18809,PP,W175,L99,NTR,D100-PJT	1	PC	SNA
19	DC93-00097A	ASSY M. WIRE HARNESS	D100,SDC18809,AC230V,CONDENSING DRYER	1	PC	SNA
20	DC63-01155A	COVER-SWITCH(M)	SDC18809,STS430,T0.4,W34,W33	1	PC	SNA
21	DC67-00425A	FAN-(C)	D100-DRYER,FRPP,OD100,GF15%	1	PC	SNA
22	DC90-02991A	ASSY BASE-SUB	D100-PJT,SDC-18809	1	PC	SNA
22-1	DC61-02478A	BASE	SDC18809,PP,W592,L531.3,NTR	1	PC	SA
22-2	DC63-01088A	COVER-FAN(P)	SDC18809,PP,W502,L144,NTR,D100-PJT	1	PC	SNA
23	DC97-15757B	ASSY HOSE DRAIN	D100,SDC18809,SINGLE BUSH HOSE,L211,GRY	1	PC	SA
23-1	DC61-02469A	BUSH-HOSE	SDC18809,EPDM+PP,ID9.6,OD15.5,L32,GRY	2	PC	SNA
23-2	DC67-00424B	HOSE-DRAIN	SDC18809,PP,ID8,OD13,T0.4,L163,GRY	1	PC	SA
24	DC67-00426A	FAN-(P)	D100-DRYER,FRPP,OD139,GF15%	1	PC	SNA
25	6021-001321	NUT-INCH	RIGHT TURN,3/8"-24,ZPC(BLK),SWCH 10AK	1	PC	SNA

5-8. SMALL PARTS

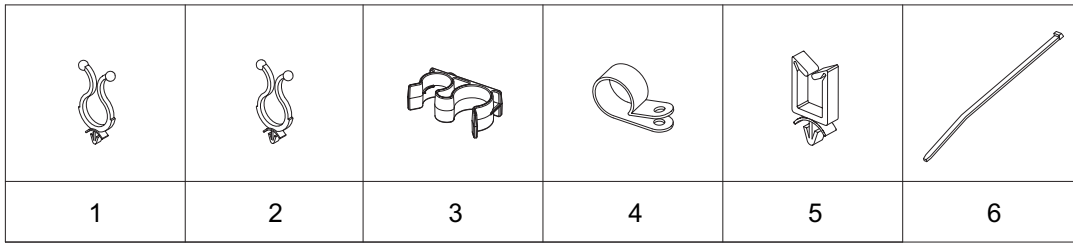

MODEL CODE: SDC18809/XEN

Service Bom (**SA**: SERVICE AVAILABLE, **SNA**: SERVICE NOT AVAILABLE)

Drawing No.	Code No.	Description	Specification	Inst point	QTY	Un	SA/SNA
1	DC61-40086A	HOLDER-WIRE	DAWH-3NB,NYLON66,-,-,-,NTR(P115)	HOLDER-CONDENSER	1	PC	SA
2	DC61-40081A	HOLDER-WIRE	DAWH-2NC,NYLON,NTR(P18.5)	FRAME	7	PC	SNA
3	DC65-00026A	CLAMPER HOSE-FIX	SDC18809,PP,BJ350,NTR	FRAME	1	PC	SA
4	DC65-20010A	CABLE CLAMP	-,-,DA-9N-1,NYLON66,NTR	COVER-FAN(P)	1	PC	SNA
5	DC61-00553B	HOLDER-WIRE SADDLE	-,NYLON66,-,-,-,NTR,DAWS-3NE	DRUM-FRONT	1	PC	SA
6	DC65-10001A	CABLE TIE	-,-,-,-,DA-140	BAG PE	2	PC	SNA

MODEL CODE: SDC16809/XEF

Service Bom (**SA**: SERVICE AVAILABLE, **SNA**: SERVICE NOT AVAILABLE)

Drawing No.	Code No.	Description	Specification	Inst point	QTY	Un	SA/SNA
1	DC61-40086A	HOLDER-WIRE	DAWH-3NB,NYLON66,-,-,-,NTR(P115)	HOLDER-CONDENSER	1	PC	SA
2	DC61-40081A	HOLDER-WIRE	DAWH-2NC,NYLON,NTR(P18.5)	FRAME	7	PC	SNA
3	DC65-00026A	CLAMPER HOSE-FIX	SDC18809,PP,BJ350,NTR	FRAME	1	PC	SA
4	DC65-20010A	CABLE CLAMP	-,-,DA-9N-1,NYLON66,NTR	COVER-FAN(P)	1	PC	SNA
5	DC61-00553B	HOLDER-WIRE SADDLE	-,NYLON66,-,-,-,NTR,DAWS-3NE	DRUM-FRONT	1	PC	SA
6	DC65-10001A	CABLE TIE	-,-,-,-,DA-140	BAG PE	2	PC	SNA

MODEL CODE: SDC14709/XEE

Service Bom (**SA**: SERVICE AVAILABLE, **SNA**: SERVICE NOT AVAILABLE)

Drawing No.	Code No.	Description	Specification	Inst point	QTY	Un	SA/SNA
1	DC61-40086A	HOLDER-WIRE	DAWH-3NB,NYLON66,-,-,-,NTR(P115)	HOLDER-CONDENSER	1	PC	SA
2	DC61-40081A	HOLDER-WIRE	DAWH-2NC,NYLON,NTR(P18.5)	FRAME	7	PC	SNA
3	DC65-00026A	CLAMPER HOSE-FIX	SDC18809,PP,BJ350,NTR	FRAME	1	PC	SA
4	DC65-20010A	CABLE CLAMP	-,-,DA-9N-1,NYLON66,NTR	COVER-FAN(P)	1	PC	SNA
5	DC61-00553B	HOLDER-WIRE SADDLE	-,NYLON66,-,-,-,NTR,DAWS-3NE	DRUM-FRONT	1	PC	SA
6	DC65-10001A	CABLE TIE	-,-,-,-,DA-140	BAG PE	2	PC	SNA

5-9. PARTS LIST (OTHERS PARTS)

MODEL CODE: SDC18809/XEN

Service Bom (SA: SERVICE AVAILABLE, SNA: SERVICE NOT AVAILABLE)

Code No.	Description	Specification	Install. Point	QTY	Un	SA/SNA
3404-001354	SWITCH-TACT	12VDC,50mA,200gf,8x13mm,SPST	SW1	1	PC	SA
3404-001354	SWITCH-TACT	12VDC,50mA,200gf,8x13mm,SPST	SW10	1	PC	SA
3404-001354	SWITCH-TACT	12VDC,50mA,200gf,8x13mm,SPST	SW11	1	PC	SA
3404-001354	SWITCH-TACT	12VDC,50mA,200gf,8x13mm,SPST	SW2	1	PC	SA
3404-001354	SWITCH-TACT	12VDC,50mA,200gf,8x13mm,SPST	SW3	1	PC	SA
3404-001354	SWITCH-TACT	12VDC,50mA,200gf,8x13mm,SPST	SW4	1	PC	SA
3404-001354	SWITCH-TACT	12VDC,50mA,200gf,8x13mm,SPST	SW5	1	PC	SA
3404-001354	SWITCH-TACT	12VDC,50mA,200gf,8x13mm,SPST	SW6	1	PC	SA
3404-001354	SWITCH-TACT	12VDC,50mA,200gf,8x13mm,SPST	SW7	1	PC	SA
3404-001354	SWITCH-TACT	12VDC,50mA,200gf,8x13mm,SPST	SW8	1	PC	SA
3501-001206	RELAY-POWER	12V DC,0.9W,-,-,20MS,10MS	RY5	1	PC	SA
3601-001567	FUSE	250V,5A,Time-Lag,21x5.7mm	F1	1	PC	SA
6002-000213	SCREW-TAPPING	TH,+,-,1,M4,L12,ZPC(WHT),SWRCH18A,-	BASE+FRAME	13	PC	SA
6002-000213	SCREW-TAPPING	TH,+,-,1,M4,L12,ZPC(WHT),SWRCH18A,-	BASE+G/DUCT FAN	1	PC	SA
6002-000213	SCREW-TAPPING	TH,+,-,1,M4,L12,ZPC(WHT),SWRCH18A,-	C/FAN(P)+G/DUCT FAN	2	PC	SA
6002-000239	SCREW-TAPPING	TH,+,-,2S,M4,L8,ZPC(WHT),SWRCH18A,-	ASSY HEATER+FRAME	2	PC	SA
6002-000239	SCREW-TAPPING	TH,+,-,2S,M4,L8,ZPC(WHT),SWRCH18A,-	THERMISTOR+FRAME	1	PC	SA
6002-000445	SCREW-TAPPING	TH,+2,M4,L18,PASS,STS304	H/DRAWER-P/CONTROL	2	PC	SA
6002-000520	SCREW-TAPPING	TH,+,-,2,M4,L12,ZPC(WHT),SWRCH18A,-	P/CONTROL+F/PLATE(U)	4	PC	SA
6006-001174	SCREW-TAPPING	TH,+WE,2S,M4,L12,ZPC(WHT),SWRC H18A	FRAME+G/DUCT FAN	5	PC	SA
6006-001174	SCREW-TAPPING	TH,+WE,2S,M4,L12,ZPC(WHT),SWRC H18A	FRAME+ASSY HEATER	2	PC	SA
6006-001174	SCREW-TAPPING	TH,+WE,2S,M4,L12,ZPC(WHT),SWRC H18A	FRAME+THERMISTOR	1	PC	SA
6009-001240	SCREW-SPECIAL	TH,+,-,M5,L12,ZPC(WHT),SWRCH18A,1,-	F/PLATE(U)+FRAME	2	PC	SA
6009-001476	SCREW-HEX	HEX,+M5,L10,ZPC(WHT),SWRCH18A,2	COVER-TOP+BKT-C/TOP	2	PC	SA
6009-001522	SCREW-HEX	HEX,+,-,M5,L16,PASS,STS430,FP,NYLOCK	ASSY-DOOR+F/FRONT	2	PC	SA
DC98-01188A	ASSY PACKING	D100,SDC18809,SW3+TAPE,W669/L695/H850	PACKING	1	PC	SA

MODEL CODE: SDC16809/XEFService Bom (**SA**: SERVICE AVAILABLE, **SNA**: SERVICE NOT AVAILABLE)

Code No.	Description	Specification	Install. Point	QTY	Un	SA/ SNA
3404-001354	SWITCH-TACT	12VDC,50mA,200gf,8x13mm,SPST	SW10	1	PC	SA
3404-001354	SWITCH-TACT	12VDC,50mA,200gf,8x13mm,SPST	SW11	1	PC	SA
3404-001354	SWITCH-TACT	12VDC,50mA,200gf,8x13mm,SPST	SW2	1	PC	SA
3404-001354	SWITCH-TACT	12VDC,50mA,200gf,8x13mm,SPST	SW3	1	PC	SA
3404-001354	SWITCH-TACT	12VDC,50mA,200gf,8x13mm,SPST	SW4	1	PC	SA
3404-001354	SWITCH-TACT	12VDC,50mA,200gf,8x13mm,SPST	SW5	1	PC	SA
3404-001354	SWITCH-TACT	12VDC,50mA,200gf,8x13mm,SPST	SW6	1	PC	SA
3404-001354	SWITCH-TACT	12VDC,50mA,200gf,8x13mm,SPST	SW7	1	PC	SA
3501-001206	RELAY-POWER	12V DC,0.9W,-,-,20MS,10MS	RY5	1	PC	SA
3601-001567	FUSE	250V,5A,Time-Lag,21x5.7mm	F1	1	PC	SA
6002-000213	SCREW-TAPPING	TH,+,-,1,M4,L12,ZPC(WHT),SWRCH18A,-	BASE+FRAME	13	PC	SA
6002-000213	SCREW-TAPPING	TH,+,-,1,M4,L12,ZPC(WHT),SWRCH18A,-	BASE+G/DUCT FAN	1	PC	SA
6002-000213	SCREW-TAPPING	TH,+,-,1,M4,L12,ZPC(WHT),SWRCH18A,-	C/FAN(P)+G/DUCT FAN	2	PC	SA
6002-000239	SCREW-TAPPING	TH,+,-,2S,M4,L8,ZPC(WHT),SWRCH18A,-	ASSY HEATER+FRAME	2	PC	SA
6002-000239	SCREW-TAPPING	TH,+,-,2S,M4,L8,ZPC(WHT),SWRCH18A,-	THERMISTOR+FRAME	1	PC	SA
6002-000445	SCREW-TAPPING	TH,+,-,2,M4,L18,PASS,STS304	H/DRAWER-P/ CONTROL	2	PC	SA
6002-000520	SCREW-TAPPING	TH,+,-,2,M4,L12,ZPC(WHT),SWRCH18A,-	P/CONTROL+F/ PLATE(U)	4	PC	SA
6009-001240	SCREW-SPECIAL	TH,+,-,M5,L12,ZPC(WHT),SWRCH18A,1,-	F/PLATE(U)+FRAME	2	PC	SA
6009-001476	SCREW-HEX	HEX,+,-,M5,L10,ZPC(WHT),SWRCH18A,2	COVER-TOP+BKT-C/ TOP	2	PC	SA
6009-001522	SCREW-HEX	HEX,+,-,M5,L16,PASS,STS430,FP,NYLOCK	ASSY-DOOR+F/ FRONT	2	PC	SA
DC98-01188A	ASSY PACKING	D100,SDC18809,SW3+TAPE,W669/L695/ H850	PACKING	1	PC	SA

MODEL CODE: SDC14709/XEEService Bom (**SA**: SERVICE AVAILABLE, **SNA**: SERVICE NOT AVAILABLE)

Code No.	Description	Specification	Install. Point	QTY	Un	SA/ SNA
3404-001354	SWITCH-TACT	12VDC,50mA,200gf,8x13mm,SPST	SW10	1	PC	SA
3404-001354	SWITCH-TACT	12VDC,50mA,200gf,8x13mm,SPST	SW11	1	PC	SA
3404-001354	SWITCH-TACT	12VDC,50mA,200gf,8x13mm,SPST	SW2	1	PC	SA
3404-001354	SWITCH-TACT	12VDC,50mA,200gf,8x13mm,SPST	SW3	1	PC	SA
3404-001354	SWITCH-TACT	12VDC,50mA,200gf,8x13mm,SPST	SW4	1	PC	SA
3404-001354	SWITCH-TACT	12VDC,50mA,200gf,8x13mm,SPST	SW5	1	PC	SA
3404-001354	SWITCH-TACT	12VDC,50mA,200gf,8x13mm,SPST	SW6	1	PC	SA
3404-001354	SWITCH-TACT	12VDC,50mA,200gf,8x13mm,SPST	SW7	1	PC	SA
3501-001206	RELAY-POWER	12V DC,0.9W,-,-,20MS,10MS	RY5	1	PC	SA
3601-001567	FUSE	250V,5A,Time-Lag,21x5.7mm	F1	1	PC	SA
6002-000213	SCREW-TAPPING	TH,+,-,1,M4,L12,ZPC(WHT),SWRCH18A,-	BASE+FRAME	13	PC	SA
6002-000213	SCREW-TAPPING	TH,+,-,1,M4,L12,ZPC(WHT),SWRCH18A,-	BASE+G/DUCT FAN	1	PC	SA
6002-000213	SCREW-TAPPING	TH,+,-,1,M4,L12,ZPC(WHT),SWRCH18A,-	C/FAN(P)+G/DUCT FAN	2	PC	SA
6002-000239	SCREW-TAPPING	TH,+,-,2S,M4,L8,ZPC(WHT),SWRCH18A,-	ASSY HEATER+FRAME	2	PC	SA
6002-000239	SCREW-TAPPING	TH,+,-,2S,M4,L8,ZPC(WHT),SWRCH18A,-	THERMISTOR+FRAME	1	PC	SA
6002-000445	SCREW-TAPPING	TH,+2,M4,L18,PASS,STS304	H/DRAWER-P/ CONTROL	2	PC	SA
6002-000520	SCREW-TAPPING	TH,+,-,2,M4,L12,ZPC(WHT),SWRCH18A,-	P/CONTROL+F/ PLATE(U)	4	PC	SA
6009-001240	SCREW-SPECIAL	TH,+,-,M5,L12,ZPC(WHT),SWRCH18A,1,-	F/PLATE(U)+FRAME	2	PC	SA
6009-001476	SCREW-HEX	HEX,+M5,L10,ZPC(WHT),SWRCH18A,2	COVER-TOP+BKT-C/ TOP	2	PC	SA
6009-001522	SCREW-HEX	HEX,+,-,M5,L16,PASS,STS430,FP,NYLOCK	ASSY-DOOR+F/ FRONT	2	PC	SA
DC68-02882A	LABEL-PANEL	SDC14709/XEE,SENA,PC,W150,L105,PANEL,D100	BAG PE	1	PC	SA
DC98-01188A	ASSY PACKING	D100,SDC18809,SW3+TAPE,W669/L695/H850	PACKING	1	PC	SA

5-10. PARTS LIST (SCREW PARTS)

MODEL CODE: SDC18809/XEN

Service Bom (SA: SERVICE AVAILABLE, SNA: SERVICE NOT AVAILABLE)

Code No.	Description	Specification	QTY	Un	SA/SNA
6001-001773	SCREW-MACHINE	TH,+,-,M5,L12,PASS,STS430,-,SEAL-LOCK	2	PC	SA
6002-000213	SCREW-TAPPING	TH,+,-,1,M4,L12,ZPC(WHT),SWRCH18A,-	15	PC	SA
6002-000215	SCREW-TAPPING	TH,+,-,NO,1,M4,L16,ZPC(WHT),SWRCH18A	6	PC	SA
6002-000234	SCREW-TAPPING	TH,+,-,NO,2S,M4,L16,ZPC(WHT),SWRCH18A	12	PC	SNA
6002-000239	SCREW-TAPPING	TH,+,-,NO,2S,M4,L8,ZPC(WHT),SWRCH18A	12	PC	SA
6002-000241	SCREW-TAPPING	TH,+,-,2S,M5,L12,ZPC(WHT),SWRCH18A,-	1	PC	SA
6002-000444	SCREW-TAPPING	TH,+,-,2,M4,L14,PASS,STS430	16	PC	SNA
6002-000445	SCREW-TAPPING	TH,+,-,2,M4,L18,PASS,STS304	4	PC	SA
6002-000520	SCREW-TAPPING	TH,+,-,2,M4,L12,ZPC(WHT),SWRCH18A,-	4	PC	SA
6002-001006	SCREW-TAPPING	TH,+,-,2S,M4,L12,PASS,STS430,-	3	PC	SNA
6002-001306	SCREW-TAPPING	TH,+,-,1,M4,L14,ZPC(WHT),SWRCH18A,-	23	PC	SNA
6002-001313	SCREW-HEX	HWH,+,-,M6.5,L25,ZPC(WHT),SWRCH18A,2,SERATION	2	PC	SA
6002-001435	SCREW-TAPPING	TH,+,-,2,M4,L12,PASS,STS430	4	PC	SNA
6003-001768	SCREW-TAPTYPE	TH,+,-,WT,S,M4,L10,ZPC(WHT),SWRCH18A	2	PC	SNA
6006-001174	SCREW-TAPPING	TH,+,-,WE,2S,M4,L12,ZPC(WHT),SWRCH18A	33	PC	SNA
6009-001240	SCREW-SPECIAL	TH,+,-,M5,L12,ZPC(WHT),SWRCH18A,1,-	2	PC	SA
6009-001476	SCREW-HEX	HEX,+,-,M5,L10,ZPC(WHT),SWRCH18A,2	2	PC	SA
6009-001522	SCREW-HEX	HEX,+,-,M5,L16,PASS,STS430,FP,NYLOCK	2	PC	SA
DC97-14006C	ASSY SCREW	GRIFFIN-PJT,WF9904RWE,SWRCH18A,M4*L16	11	PC	SA

MODEL CODE: SDC16809/XEFService Bom (**SA**: SERVICE AVAILABLE, **SNA**: SERVICE NOT AVAILABLE)

Code No.	Description	Specification	QTY	Un	SA/SNA
6001-001773	SCREW-MACHINE	TH,+,-,M5,L12,PASS,STS430,-,SEAL-LOCK	2	PC	SA
6002-000213	SCREW-TAPPING	TH,+,-,1,M4,L12,ZPC(WHT),SWRCH18A,-	15	PC	SA
6002-000215	SCREW-TAPPING	TH,+,-,NO,1,M4,L16,ZPC(WHT),SWRCH18A	6	PC	SA
6002-000234	SCREW-TAPPING	TH,+,-,NO,2S,M4,L16,ZPC(WHT),SWRCH18A	12	PC	SNA
6002-000239	SCREW-TAPPING	TH,+,-,NO,2S,M4,L8,ZPC(WHT),SWRCH18A	12	PC	SA
6002-000241	SCREW-TAPPING	TH,+,-,2S,M5,L12,ZPC(WHT),SWRCH18A,-	1	PC	SA
6002-000444	SCREW-TAPPING	TH,+,-,2,M4,L14,PASS,STS430	16	PC	SNA
6002-000445	SCREW-TAPPING	TH,+,-,2,M4,L18,PASS,STS304	4	PC	SA
6002-000520	SCREW-TAPPING	TH,+,-,2,M4,L12,ZPC(WHT),SWRCH18A,-	4	PC	SA
6002-001006	SCREW-TAPPING	TH,+,-,2S,M4,L12,PASS,STS430,-	3	PC	SNA
6002-001306	SCREW-TAPPING	TH,+,-,1,M4,L14,ZPC(WHT),SWRCH18A,-	23	PC	SNA
6002-001313	SCREW-HEX	HWH,+,-,M6.5,L25,ZPC(WHT),SWRCH18A,2,SERATION	2	PC	SA
6002-001435	SCREW-TAPPING	TH,+,-,2,M4,L12,PASS,STS430	4	PC	SNA
6003-001768	SCREW-TAPTYPE	TH,+,-,WT,S,M4,L10,ZPC(WHT),SWRCH18A	2	PC	SNA
6006-001174	SCREW-TAPPING	TH,+,-,WE,2S,M4,L12,ZPC(WHT),SWRCH18A	33	PC	SNA
6009-001240	SCREW-SPECIAL	TH,+,-,M5,L12,ZPC(WHT),SWRCH18A,1,-	2	PC	SA
6009-001476	SCREW-HEX	HEX,+,-,M5,L10,ZPC(WHT),SWRCH18A,2	2	PC	SA
6009-001522	SCREW-HEX	HEX,+,-,M5,L16,PASS,STS430,FP,NYLOCK	2	PC	SA
DC97-14006C	ASSY SCREW	GRIFFIN-PJT,Wf9904RWE,SWRCH18A,M4*L16	11	PC	SA

MODEL CODE: SDC14709/XEEService Bom (**SA**: SERVICE AVAILABLE, **SNA**: SERVICE NOT AVAILABLE)

Code No.	Description	Specification	QTY	Un	SA/SNA
6001-001773	SCREW-MACHINE	TH,+,-,M5,L12,PASS,STS430,-,SEAL-LOCK	2	PC	SA
6002-000213	SCREW-TAPPING	TH,+,-,1,M4,L12,ZPC(WHT),SWRCH18A,-	15	PC	SA
6002-000215	SCREW-TAPPING	TH,+,-,NO,1,M4,L16,ZPC(WHT),SWRCH18A	6	PC	SA
6002-000234	SCREW-TAPPING	TH,+,-,NO,2S,M4,L16,ZPC(WHT),SWRCH18A	12	PC	SNA
6002-000239	SCREW-TAPPING	TH,+,-,NO,2S,M4,L8,ZPC(WHT),SWRCH18A	12	PC	SA
6002-000241	SCREW-TAPPING	TH,+,-,2S,M5,L12,ZPC(WHT),SWRCH18A,-	1	PC	SA
6002-000444	SCREW-TAPPING	TH,+,-,2,M4,L14,PASS,STS430	13	PC	SNA
6002-000445	SCREW-TAPPING	TH,+,-,2,M4,L18,PASS,STS304	4	PC	SA
6002-000520	SCREW-TAPPING	TH,+,-,2,M4,L12,ZPC(WHT),SWRCH18A,-	4	PC	SA
6002-001006	SCREW-TAPPING	TH,+,-,2S,M4,L12,PASS,STS430,-	3	PC	SNA
6002-001306	SCREW-TAPPING	TH,+,-,1,M4,L14,ZPC(WHT),SWRCH18A,-	23	PC	SNA
6002-001313	SCREW-HEX	HWH,+,-,M6.5,L25,ZPC(WHT),SWRCH18A,2,SERATION	2	PC	SA
6002-001435	SCREW-TAPPING	TH,+,-,2,M4,L12,PASS,STS430	4	PC	SNA
6003-001768	SCREW-TAPTYPE	TH,+,-,WT,S,M4,L10,ZPC(WHT),SWRCH18A	2	PC	SNA
6006-001174	SCREW-TAPPING	TH,+,-,WE,2S,M4,L12,ZPC(WHT),SWRCH18A	33	PC	SNA
6009-001240	SCREW-SPECIAL	TH,+,-,M5,L12,ZPC(WHT),SWRCH18A,1,-	2	PC	SA
6009-001476	SCREW-HEX	HEX,+,-,M5,L10,ZPC(WHT),SWRCH18A,2	2	PC	SA
6009-001522	SCREW-HEX	HEX,+,-,M5,L16,PASS,STS430,FP,NYLOCK	2	PC	SA
DC97-14006C	ASSY SCREW	GRIFFIN-PJT,Wf9904RWE,SWRCH18A,M4*L16	11	PC	SA