

# 1. Freezer

## Exploded View

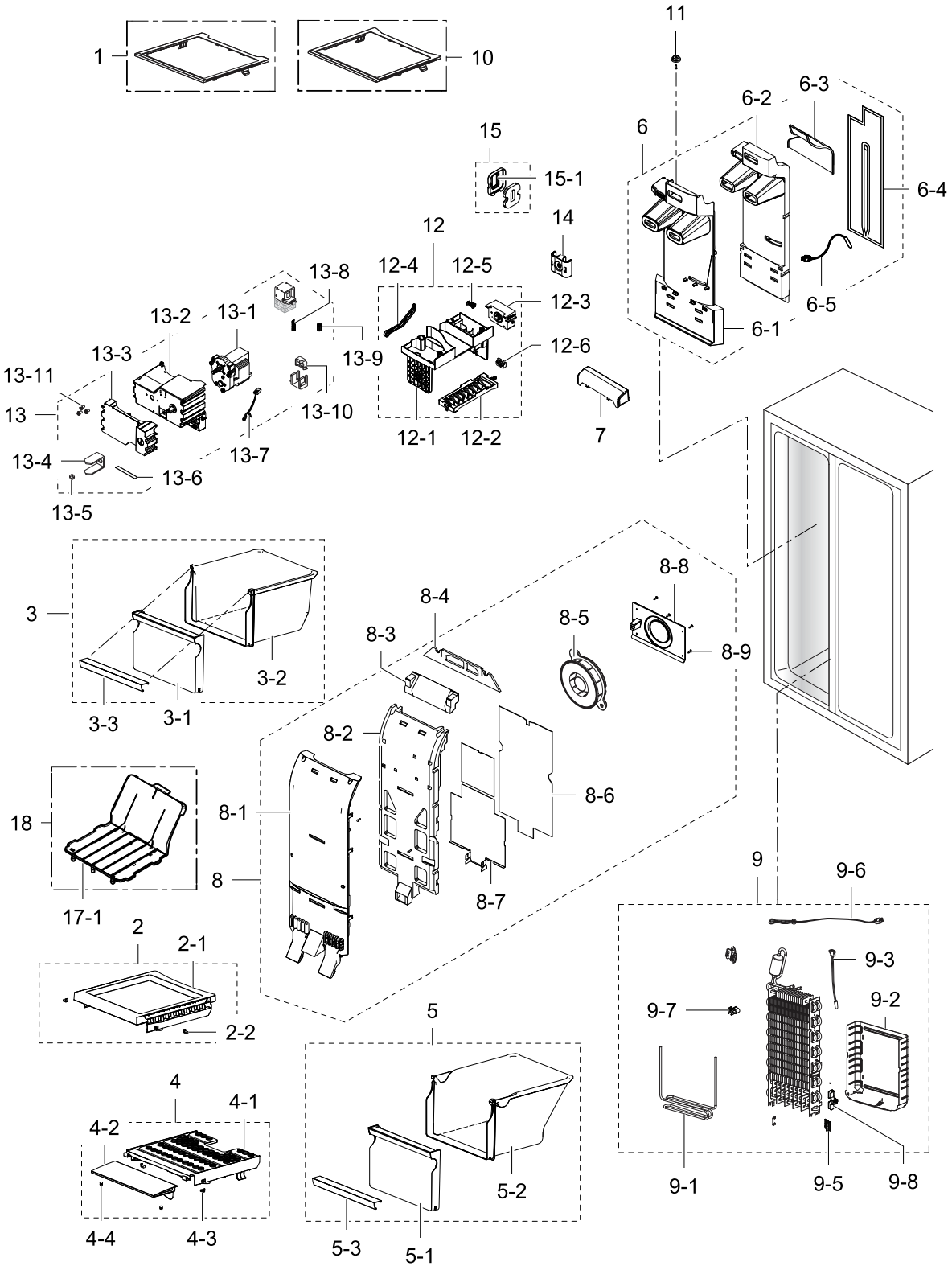

**Parts List**

No.	Lvl.	Loc.	Material Code	Description & Specification	SNA	Qty.
1	2		DA97-16728A	ASSY SHELF-FRE UP; RS4000K	SA	1
2	2	M0310	DA97-12766A	ASSY SHELF FRE-LOW; HM10-SEPM,RAIL TWO-PI	SA	1
2-1	3	Z1179	DA67-03384A	SHELF FRE-LOW; HERMES,ABS,COOL WHITE,HB,H	SNA	1
2-2	3	G0587	DA63-00202C	GROMMET-RAIL; TD-PJT,PA66,W10.7,COOL WHIT	SA	6
3	2	Z1189	DA97-12803B	ASSY CASE-BASKET HIGH; HM12-PJT	SA	1
3-1	3	A1182	DA63-07075A	COVER BASKET-HIGH; HM12,GPPS,HB,165N,TP B	SA	1
3-2	3		DA61-08435A	CASE BASKET-HIGH; HM12,GPPS,TP BLUE,HB,16	SA	1
3-3	3		DA64-03862K	TRIM-TRAY FRE; HERMES-12,HIPS,S834S1,COOL	SA	2
4	2		DA97-12807A	ASSY COVER-SLIDE BASKET; HM12-PJT	SA	1
4-1	3	G0408	DA63-07054A	COVER BASKET-LOW; HM10,ABS,HB,COOL WHITE,	SNA	1
4-2	3		DA63-07077A	COVER SLIDE-BASKET; HM12,PETG,HB,NATURAL,	SNA	1
4-3	3	G0587	DA63-00202C	GROMMET-RAIL; TD-PJT,PA66,W10.7,COOL WHIT	SA	6
4-4	3		DA63-07113A	GROMMET-COVER SIDE; HM12,SI,Transparency	SA	4
5	2	A0496	DA97-12804B	ASSY CASE-BASKET LOW; HM12-PJT	SA	1
5-1	3	G0408	DA63-07074A	COVER BASKET-LOW; HM12,GPPS,HB,165N,TP, B	SNA	1
5-2	3	G0407	DA61-08434A	CASE BASKET-LOW; HM12,GPPS,TP BLUE,HB,165	SNA	1
5-3	3		DA64-03862K	TRIM-TRAY FRE; HERMES-12,HIPS,S834S1,COOL	SA	2
6	2	Z1178	DA97-12926A	ASSY COVER MULTI FRE; HM12,COOL WHITE	SA	1
6-1	3		DA63-07193A	COVER-MULTI FRE; HM12,PP,HB,COOL WHITE,EP	SNA	1
6-2	3		DA62-03789A	INSULATION-MULTI FRE; HM12,PS FOAM,WHT	SNA	1
6-3	3		DA61-03393B	PLATE DUCT-FRE REAR UP; HERMES,PP,T1,NATU	SNA	1
6-4	3		DA62-01438A	SEAL-COVER MULTI FRE REAR; HERMES,PE FOAM	SNA	1
6-5	3	A1018	DA32-10105V	SENSOR TEMP; 502AT, DKST1329GW, PX-41C,N	SNA	1
7	2	M0152	DA63-07192A	COVER-LAMP FRE; HM12,PP,HB,NATURAL,EP448T	SA	1

No.	Lvl.	Loc.	Material Code	Description & Specification	SNA	Qty.
8	2	M0303	DA97-12820A	ASSY COVER EVAP-FRE; HM12,BASIC, AIO Slim	SA	1
8-1	3		DA63-07060A	COVER EVAP-FRE; HM12,PP,HB,COOL WHITE,EP4	SNA	1
8-2	3		DA62-03720A	INSULATION-EVAP FRE A; HM12,PS FOAM,WHITE	SNA	1
8-3	3		DA62-03722A	INSULATION-EVAP FRE B; HM12,PS FOAM,WHITE	SNA	1
8-4	3		DA62-03765A	SEAL-COVER EVAP FRE HIGH; HM12,PE FOAM,WH	SNA	1
8-5	3		DA31-00334C	MOTOR BLDC FAN; 12035GE-12M-YT-F1,17757	SA	2
8-6	3		DA62-03764A	SEAL-COVER EVAP FRE REAR; HM12,FOAM-PE+AL	SA	1
8-7	3		DA61-05991C	PLATE-EVAP HEATER FRE; HERMES,GL-SAZCC,T0	SA	1
8-8	3	M0143	DA61-08425A	CASE-MOTOR FRE; HM12,ABS,LIGHT GRAY,CNTK	SA	1
8-9	3	G0412	6002-001204	SCREW-TAPPING; TH,+,-,1,M4,L16,PASS,STS43	SNA	8
9	2	A0163	DA96-00675U	ASSY EVAP-FRE; HM12,FIN TUBE,A1070,230V,2	SA	1
9-1	3	G0515	DA47-00320L	HEATER METAL SHEATH; AC230V,HM10 FRE, 264	SNA	1
9-2	3		DA61-05989B	PLATE-DRAIN EVAP FRE; HERMES,GL-SAZCC,T0.	SNA	1
9-3	3	A1018	DA32-00029N	SENSOR TEMP; DTN-C502G6X,DKST1329GW,NEXT-	SNA	1
9-5	3	A0744	DA61-05160A	FIXER FUSE; CULLI_09,PP,T2.0,NATURAL,HB,B	SNA	2
9-6	3	A1008	DA47-00301F	THERMO FUSE-ASSY; AC250V,10A,109~110??S	SNA	1
9-7	3	M0475	DA61-06013A	FIXER-WIRE; AW3-PJT,PP,NTR	SNA	3
9-8	3	G0521	DA61-06691A	FIXER-WIRE FRE SUB; HM/GGH/HAEMIL,PP,NATU	SNA	1
10	2		DA97-16729A	ASSY SHELF-FRE MIDDLE; RS4000K	SA	1
11	2	G0200	DA61-01797A	FIXER GROMMET-DOOR; T3-PJT,PP,T2.5,COOL W	SA	2
12	2	M0247	DA97-05071B	ASSY ICE MAKER-MECH; HERMES,-,-,-,-	SA	1
12-1	3	Z1244	DA61-03352B	SUPPORT ICE MAKER; HERMES,HIPS,-,-,-, NATU	SNA	1
12-2	3	A0120	DA63-02284B	TRAY ICE; AD,PP,HB,NATURAL	SA	1
12-3	3	Z1220	DA59-00294B	ICE MAKER-ASSY; ASSY	SNA	1
12-4	3	Z1221	DA61-00954B	GUIDE-ICE FULL; AW,ABS,-,-,-,NTR,-	SA	1
12-5	3		DA63-02183A	COVER-SENSOR; AD,PPT1,WHITE	SA	1
12-6	3		DA61-01800A	FIXER SENSOR; AD,URETHANE,-,-,-	SNA	1

Exploded Views and Parts List

No.	Lvl.	Loc.	Material Code	Description & Specification	SNA	Qty.
13	2		DA97-08744D	ASSY-CASE AUGER MOTOR; HERMES10,LED,230V,	SA	1
13-1	3	M0199	DA31-00105F	MOTOR GEARED AC AUGER; ISG3240SSH-1 / ORG	SA	1
13-2	3	M0393	DA61-06042A	CASE-AUGER MOTOR; HM10,ABS,COOL-WHITE(SC-	SA	1
13-3	3		DA63-03528B	COVER-AUGER MOTOR; HERMES,PP,HB,NATURAL,E	SA	1
13-4	3		DA70-20017A	PLATE-D/AUGER DISP; STS304,T3	SA	1
13-5	3	M0166	DA71-00163A	FIXER-NUT; ZIPEL,STS420,T1,-,CLIP,STS420-	SA	1
13-6	3		DA41-00749B	ASSY LAMP LED; 6ea,FR-4,129*15,WHITE,SMAW	SA	1
13-7	3	M0260	DA96-00036Z	ASSY WIRE HARNESS-AUGER; ALL,FREE VOLT,UL	SA	1
13-8	4		DA61-20140A	SPRING ETC-SOLENOID; SR-S7180,STS304,ID7.	SA	1
13-9	4	M0263	DA63-90008A	BUSH-SOLENOID; -,POM,-,-,SC-93438R,-	SA	1
13-10	4		DA61-60001A	SLIDER-SOLENOID DISP; SSED PJT,POM,NATUR	SA	1
13-11	3	T0036	DA60-00001B	SCREW-SPECIAL; HEX,L6.3,PASS,STS304	SA	3
14	2		DA61-03467B	FIXER-HOSE; AW-PJT,HIPS,NATURAL,S834S1	SA	1
15	2	M0083	DA97-00979C	ASSY COVER-PIPE WATER; HERMES-PJT,PP RECY	SA	1
15-1	3	Z1120	DA63-00476B	COVER PIPE; HERMES-PJT,PP,BLACK,SCRAP	SA	1
17-1	3		DA67-03869A	SHELF-BOTTOM; HM12,HIPS,COOL WHITE,454N,H	SNA	1
18	2		DA97-14635A	ASSY SHELF-FRE BOTTOM; HM A+++	SA	1

# 2. Fridge

## Exploded View

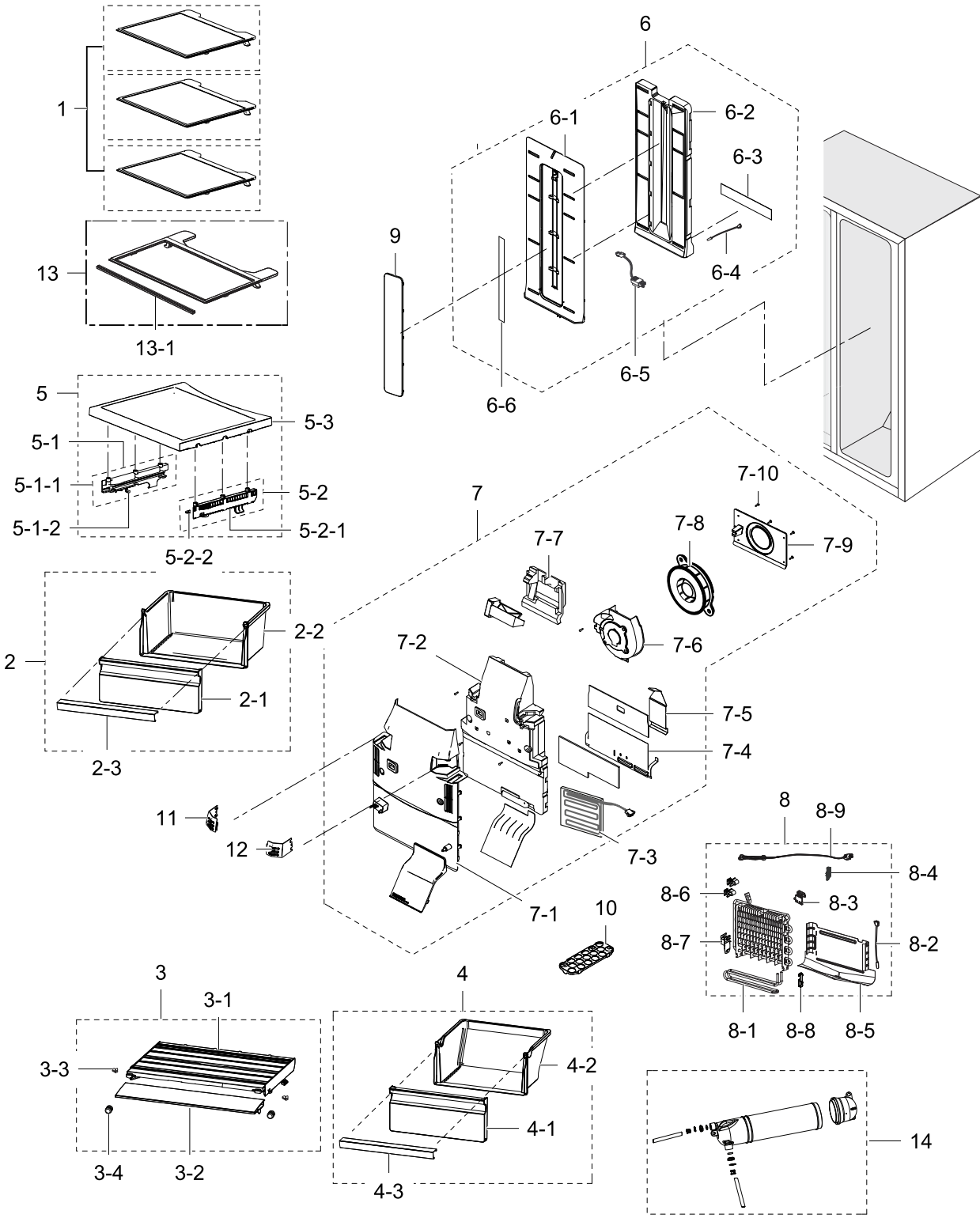

**Parts List**

No.	Lvl.	Loc.	Material Code	Description & Specification	SNA	Qty.
1	2	M0293	DA67-04253A	SHELF-REF UP; RS4000K,PP,COOL WHITE,EP448	SA	3
2	2	Z1188	DA97-12801B	ASSY CASE-VEG HIGH; HM12-PJT	SA	1
2-1	3	A1183	DA63-07072A	COVER VEG-HIGH; HM12,GPPS,HB,TP BLUE,165N	SNA	1
2-2	3	A0677	DA61-08432A	CASE VEG-HIGH; HM12,GPPS,TP BLUE,HB,165N,	SNA	1
2-3	3		DA64-03862L	TRIM-TRAY FRE; HERMES-12,HIPS,S834S1,COOL	SA	2
3	2		DA97-12806A	ASSY COVER-SLIDE VEG; HM12-PJT	SA	1
3-1	3	M0272	DA63-07017A	COVER VEG-LOW; HM10,ABS,HB,COOL WHITE,HG-	SNA	1
3-2	3		DA63-07076A	COVER SLIDE-VEG; HM12,PETG,HB,NATURAL,T90	SNA	1
3-3	3	G0587	DA63-00202C	GROMMET-RAIL; TD-PJT,PA66,W10.7,COOL WHIT	SA	6
3-4	3		DA63-07113A	GROMMET-COVER SIDE; HM12,SI,Transparency	SA	4
4	2	M0236	DA97-12802B	ASSY CASE-VEG LOW; HM12-PJT	SA	1
4-1	3	M0272	DA63-07073A	COVER VEG-LOW; HM12,GPPS,HB,TP BLUE,HI-IM	SNA	1
4-2	3	M0268	DA61-08433A	CASE VEG-LOW; HM12,GPPS,TP BLUE,HB,165N,H	SNA	1
4-3	3		DA64-03862L	TRIM-TRAY FRE; HERMES-12,HIPS,S834S1,COOL	SA	2
5	2	G0284	DA97-12764A	ASSY SHELF REF-LOW; HM10-SEPM,RAIL-TWO PI	SA	1
5-1	3	G0565	DA97-05233B	ASSY RAIL-BOX L; HERMES-PJT,T2.0,W17,L260	SA	1
5-1-1	4		DA61-03413B	RAIL-BOX L; HERMES-PJT,TALC PP,-,-,NATU	SNA	1
5-1-2	4	G0587	DA63-00202C	GROMMET-RAIL; TD-PJT,PA66,W10.7,COOL WHIT	SA	2
5-2	3	G0566	DA97-05234B	ASSY RAIL-BOX R; HERMES-PJT,T2.0,W17,L260	SA	1
5-2-1	4		DA61-03412B	RAIL-BOX R; HERMES-PJT,TALC PP,-,-,NATU	SNA	1
5-2-2	4	G0587	DA63-00202C	GROMMET-RAIL; TD-PJT,PA66,W10.7,COOL WHIT	SA	2
5-3	3	A0682	DA67-03385A	SHELF REF-LOW; HM10,ABS,COOL WHITE,HG-076	SNA	1
6	2	G0239	DA97-12823A	ASSY COVER MULTI-REF; HM12,COOL WHITE,LED	SA	1
6-1	3	A0689	DA63-07081A	COVER MULTI-REF; HM12,PP,HB,COOL WHITE,EP	SNA	1
6-2	3	A0695	DA62-03726A	INSULATION-MULTI REF; HM12,PS FOAM,WHITE,	SNA	1

No.	Lvl.	Loc.	Material Code	Description & Specification	SNA	Qty.
6-3	3		DA61-03361A	PLATE-MULTI REF REAR; HERMES,PP,T0.6,-,-,	SNA	1
6-4	3	A1018	DA32-10105U	SENSOR TEMP; 502AT,A-TOP,-50~50,5V,-,-,RO	SA	1
6-5	3	G0563	DA96-00424F	ASSY WIRE HARNESS-LED; ALL,12VDC,ALL,UL,A	SA	1
6-6	3	T0096	DA41-00519Y	ASSY LAMP LED; 9ea,FR-4,490*20,WHITE,SMAW	SA	1
7	2	Z1177	DA97-12824A	ASSY COVER EVAP-REF; HM12,COOL WHITE,BASI	SA	1
7-1	3		DA63-07079A	COVER EVAP-REF; HM12,PP,HB,COOL WHITE,EP4	SNA	1
7-2	3		DA62-03727A	INSULATION EVAP-REF A; HM12,PS FOAM,WHITE	SNA	1
7-3	3	G0514	DA47-00258A	HEATER-WATER TANK; AC230V,HERMES, 10580oh	SA	1
7-4	3		DA61-05993B	PLATE-EVAP HEATER REF; HERMES,Al,T0.3	SA	1
7-5	3		DA61-06244A	PLATE-DRAIN INS EVAP REF; HERMES,A1100,T0	SA	1
7-6	3		DA61-08437A	GUIDE AIR-REF; HM12,HIPS,HB,454N,NATURAL,	SA	1
7-7	3		DA62-03734A	INSULATION EVAP-REF B; HM12,PS FOAM,WHITE	SNA	1
7-8	3		DA31-00334C	MOTOR BLDC FAN; 12035GE-12M-YT-F1,17757	SA	2
7-9	3		DA61-08438A	PLATE-MOTOR REF; HM12,ABS,T2,NATURAL,AIO	SA	1
7-10	3	G0412	6002-001204	SCREW-TAPPING; TH,+,-,1,M4,L16,PASS,STS43	SNA	8
8	2	A0184	DA96-00676K	ASSY EVAP-REF; HERMES,FIN PIPE,A1070S-H14	SA	1
8-1	3	A0921	DA47-00321L	HEATER METAL SHEATH; AC230V,HM10 REF, 377	SA	1
8-2	3	A1018	DA32-00029R	SENSOR TEMP; DTN-C502G6X, DKST1329GW,SSED	SA	1
8-3	3		DA61-03683A	FIXER-SENSER; AW-PJT,PP,NATURAL,V-0	SNA	1
8-4	3	A0744	DA61-05160A	FIXER FUSE; CULLI_09,PP,T2.0,NATURAL,HB,B	SNA	2
8-5	3	M0404	DA61-05702B	PLATE-DRAIN EVAP REF; HERMES, GUGGENHEIM,	SNA	1
8-6	3	M0475	DA61-06013A	FIXER-WIRE; AW3-PJT,PP,NTR	SNA	3
8-7	3	G0519	DA61-06062A	PLATE-EVAP BRACKET REF; HERMES/GUGGENHEIM	SA	1
8-8	3	G0522	DA61-06700A	FIXER-HEATER WIRE REF; HM/GGH/HAEMIL,PP,N	SNA	2
8-9	3	A1008	DA47-00301B	THERMO FUSE-ASSY; AC250V,10A,109~110??S	SA	1
9	2	A0710	DA63-07034A	COVER-LAMP REF; HM10-SEPM,PP,HB,NATURAL,E	SA	1
10	2	Z1106	DA67-40322A	TRAY-EGG; SR-51.55.59,GPPS,-,-,-,-,-	SA	1

Exploded Views and Parts List

No.	Lvl.	Loc.	Material Code	Description & Specification	SNA	Qty.
11	2		DA63-07080A	COVER DEODORIZER-L; HM12,PP,HB,COOL WHITE	SA	1
12	2		DA63-07083A	COVER DEODORIZER-R; HM12,PP,HB,COOL WHITE	SA	1
13	2	A0909	DA97-12797B	ASSY SHELF-REF MID; HM12-PJT,WHITE TRIM	SA	1
13-1	3		DA64-03760E	TRIM SHELF-REAR; HERMES-12,ABS,HG-06601,L	SA	1
14	2	M0042	DA97-12702B	ASSY TANK WATER; HM10 SEPM,ASSY,NTR	SA	1



# 3. Cabinet

## Exploded View

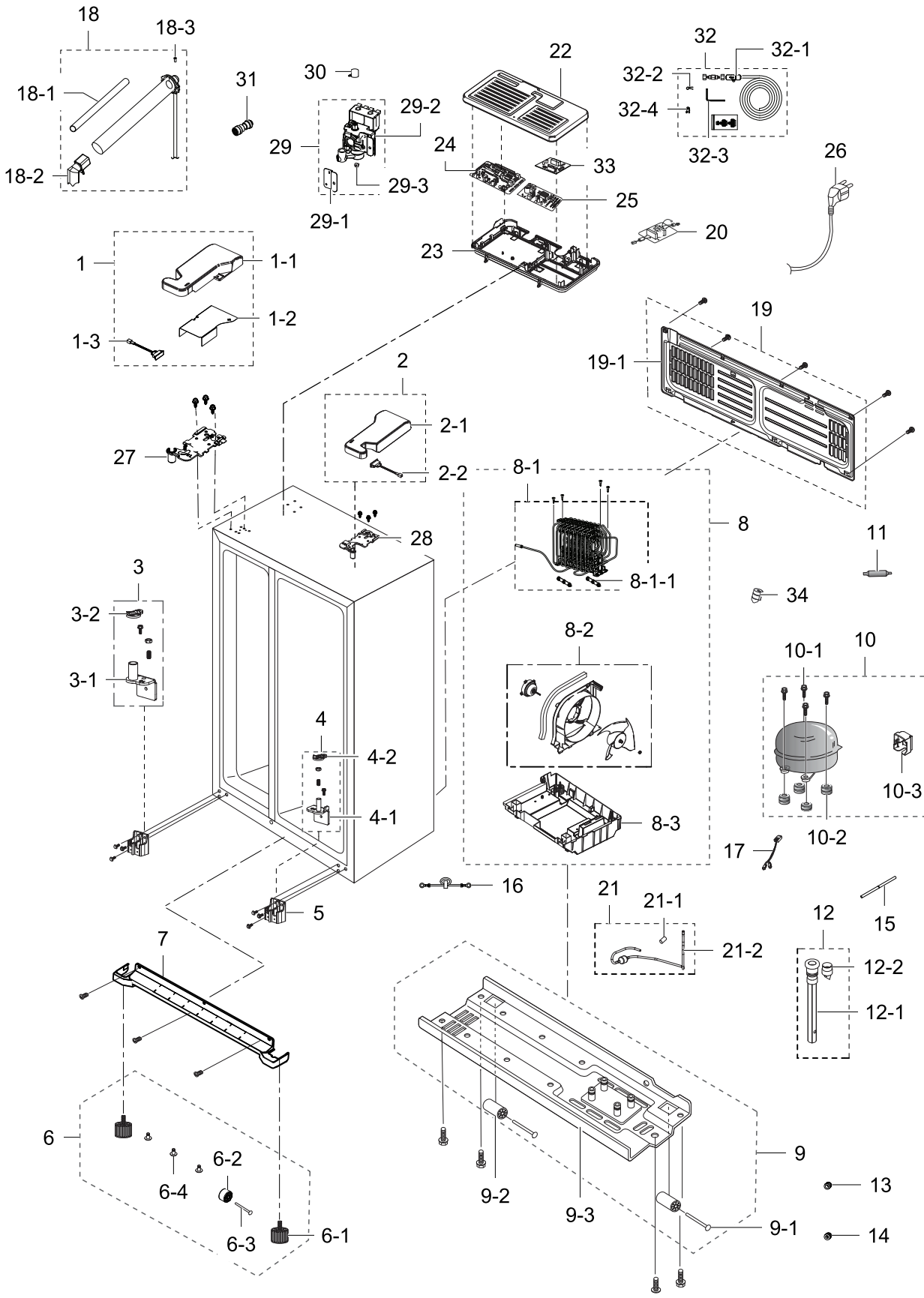

**Parts List**

No.	Lvl.	Loc.	Material Code	Description & Specification	SNA	Qty.
1	2	A0241	DA97-12758A	ASSY COVER HINGE-UPP L; HM10-SEPM,T2.5,15	SNA	1
1-1	3	A0913	DA63-07032A	COVER-HINGE UPP L; HM10-SEPM,ABS,T2.5,156	SA	1
1-2	3	M0289	DA61-08395A	PLATE-COVER HINGE; HM10-SEPM,GI-SGCC,T0.3	SA	1
1-3	3	G0068	DA34-00043C	SWITCH REED; 13mm,UL1007 AWG 22,100,HOOK	SA	2
2	2	A0243	DA97-06159C	ASSY COVER HINGE-UPP R; GUGGENHEIM(EXP),T	SA	1
2-1	3	A0244	DA63-04180C	COVER HINGE-UPP R; GUGGENHEIM(EXP),ABS,T2	SA	1
2-2	3	G0068	DA34-00043C	SWITCH REED; 13mm,UL1007 AWG 22,100,HOOK	SA	2
3	2	M0245	DA97-06158B	ASSY HINGE LOW-L; GUGGENHEIM,BLK	SA	1
3-1	3	A0947	DA61-04191A	HINGE-LOW LEFT; GUGGENHEIM,PO-SPHC,T4.5	SNA	1
3-2	3	G0556	DA66-00560B	CAM HINGE-RISER LOW L; GUGGENHEIM,PA66,BL	SNA	1
4	2	M0246	DA97-06157B	ASSY HINGE LOW-R; GUGGENHEIM,BLK	SA	1
4-1	3		DA61-04190A	HINGE-LOW R; GUGGENHEIM,PO-SPHC,T4.5	SNA	1
4-2	3	G0555	DA66-00559A	CAM HINGE-RISER LOW R; GUGGENHEIM,PA66,BL	SNA	1
5	2	G0520	DA61-06104B	BRACKET HINGE-LOW; HM10,AI	SA	2
6	2		DA97-12691B	ASSY CABINET-BOTTOM FRAME; HM10-SEPM,DISP	SNA	1
6-1	3	A0577	DA61-00805F	FOOT-FRONT; REF-ALL,PP,BLACK,PP_S	SA	2
6-2	3	M0145	DA61-04702A	CASTER-FRONT; AW-PJT,PP,BLACK,PP(M/B 0103	SA	1
6-3	3	M0146	DA61-01920A	FIXER-CASTER; ZPC2,SWRCH10A,OD8.0,L58	SA	3
6-4	3	G0412	6002-000239	SCREW-TAPPING; TH,+,NO,2S,M4,L8,ZPC(WHT),	SA	4
7	2	A0807	DA63-05292A	COVER LEG-FRONT; HM10,PP,HB,STS-KP,EP448T	SA	1
8	2	A0529	DA97-12869B	ASSY TRAY DRAIN WATER; HM14 A+,C160,SPIRA	SA	1
8-1	3	M0349	DA97-03962E	ASSY PIPE-SPIRAL COND; HERMES-PJT,VE	SC	1
8-1-1	4	M0181	DA63-40128A	GROMMET-SUB COND; -,NBR,-,-,-,-,-,DARK-	SA	2
8-2	3	M0116	DA97-15765C	ASSY SUPPORT-CIRCUIT MOTOR; RH9000K	SA	1
8-3	3		DA97-13057B	ASSY TRAY DRAIN WATER-SUB; HM12 SEPM	SA	1
9	2	A0738	DA97-12777A	ASSY CHASSIS-COMP; HM10,IN_DOOR	SNA	1
9-1	3	M0146	DA61-01920A	FIXER-CASTER; ZPC2,SWRCH10A,OD8.0,L58	SA	3

No.	Lvl.	Loc.	Material Code	Description & Specification	SNA	Qty.
9-2	3	A0527	DA61-04703A	CASTER-REAR; AW-PJT,PP,BLACK,PP M/B(0103-	SA	2
9-3	3	G0580	DA97-12818A	ASSY CHASSIS-COMP SUB; HM10,IN_DOOR	SA	1
10	2		ENV4A5GL2J/AK3	CMP,COMP,REFRIGERATOR,R-600A; CMP,COMP,REFRIGERATOR,R-600A		1
10-1	3	A0564	6011-004061	BOLT-HEX; M6,L43.6,SWRCH10A	SNA	4
10-2	3	Z1112	DA63-02617A	GROMMET COMP; USP05,EPDM,OD27.0,BLACK	SA	4
10-3	3	Z1032	DA63-06122A	COVER RELAY; MSV,MPPO,T2,BLACK,V-0	SA	1
11	2	A0669	DA62-04309B	DRYER; Cu,137,SINGLE MOUTH,9g	SA	1
12	2	A1100	DA97-04045A	ASSY TUBE-DRAIN; ET-PJT,SOFT-PVC	SA	2
12-1	3	G0070	DA62-01268A	TUBE-PVC; A-TOP,SF-PVC,T0.7,OD19.4,L215,-	SNA	2
12-2	3	G0202	DA63-00951C	GROMMET-DRAIN HOSE; V2-PJT,NBR,BLACK	SNA	2
13	2		DA60-00280A	FITTING-LOKRING 33; SUM23,33, 11SMnPb30K	SA	1
14	2		DA60-00281A	FITTING LOKRING; SUM23,ID5.02,11SMnPb30K,	SA	1
15	2	A0523	DA73-10190U	PIPE-CONNECT DISC,B; ALL,Cu,C1220T,OD6.35	SA	1
16	2	A0562	DA39-20389L	ASSY WIRE HARNESS-EARTH; ALL,FREE VOLT,UL	SA	1
17	2		DA96-00964S	ASSY WIRE HARNESS-MAIN; SBS,220~240VAC,IE	SNA	1
18	2	M0462	DA97-05070A	ASSY-PIPE WATER FRE; HERMES,230V/10W,-,-	SC	1
18-1	3	Z1218	DA47-00035P	HEATER-WATER PIPE; AC230V,HERMES, 5290ohm	SA	1
18-2	3		DA63-03629A	GROMMET-WATER PIPE FILL IN; HERMES,SI,ICE	SNA	1
18-3	3	M0278	DA71-20208A	FIXER-VALVE WATER B; SR-S7180,PA6,-,BLUE	SA	1
19	2	M0076	DA97-12759A	ASSY COVER COMP; HM10-SEPM,SGCC,T0.3	SA	1
19-1	3	Z1131	DA63-07209A	COVER COMP; HM12,GI-SGCC,T0.3	SNA	1
20	2	M0489	DA27-00041B	COIL FILTER; 14.0mH,60*82mm,AC 5A,0.68uF	SA	1
21	2		DA97-12874A	ASSY PIPE CONNECT; HERMES PJT	SA	1
21-1	3	M0334	DA63-40171D	GROMMET-SUCT PIPE B; RAIL L20,NBR,-,ID5.5	SA	1
21-2	3	M0016	DA62-03691A	PIPE CONNECT-SUCTION; C1220T-O,OD6.35,T0.	SA	1
22	2	G0089	DA63-05419A	COVER PCB-PANEL; HAEMIL_CULLI,GI-SGCC,T0.	SA	1
23	2		DA61-10737A	CASE PBA-MAIN; ABS,SNOW WHITE	SNA	1
24	1	A0952	DA92-00813D	ASSY PCB MAIN; ASSY PCB MAIN,HM12,247*197	SA	1
25	2		DA92-00763F	ASSY PCB INVERTER; INVERTER,HM12,163*98.5	SA	1

## Exploded Views and Parts List

No.	Lvl.	Loc.	Material Code	Description & Specification	SNA	Qty.
26	2	A0273	3903-001015	CBF-POWER CORD; AT,EU,EU3F,3C,250V,16A,BI	SA	1
27	2	M0286	DA61-04188B	HINGE-UPP L; GUGGENHEIM(EXP),PO-SPHC,T3.0	SA	1
28	2	A0813	DA61-04189B	HINGE-UPP R; GUGGENHEIM(EXP),SHP1,T3.0,-,	SA	1
29	2	M0315	DA97-07827J	ASSY VALVE WATER; HM10,NO FLOW SENSOR, 22	SA	1
29-1	3		DA61-05859A	BRACKET-WATER VALVE; HM10,GI-SGCC,T1.6,FL	SNA	1
29-2	3	G0527	DA62-02291E	VALVE WATER; AC220-240V,120,2WAY,L-Wire,1	SNA	1
29-3	3	G0412	6002-000239	SCREW-TAPPING; TH,+,NO,2S,M4,L8,ZPC(WHT),	SA	4
30	2		DA67-03471A	CAP-NUT; HM12,SILICON,14,BLUE	SNA	1
31	2	T0093	DA60-00258B	FITTING-TUBE; TUBE FITTING A,PP,1/4,1/4'-	SA	1
32	2	A0684	DA97-11752M	ASSY-INSTALL FILTER; HM,EXTERNAL FILTER	SA	1
32-1	3		DA63-04744A	COVER-CHECK VALVE; HM,PP,HB,GRAY,CNTK-P-1	SA	1
32-2	3	G0589	DA65-20110B	CABLE CLAMP; PA66	SNA	8
32-3	3	Z1222	DA80-00002F	WRENCH-SPANNER; AW3,SM45C,Zn PLATING	SNA	1
32-4	3		DA61-04522A	CLIP-FITTING LOCK; AW,POM	SNA	8
33	1		DA92-00530A	ASSY MODULE; STD #7 SMPS,FOOD SHOWCASE,32	SA	1
34	2		DA63-08943A	GROMMET; BRR9000M,NBR,CAPI GROMMET	SA	1



**Parts List**

No.	Lvl.	Loc.	Material Code	Description & Specification	SNA	Qty.
1	2	A0051	DA91-03832B	ASSY DOOR FOAM FRE; RS757*/RS756*,ALF,R,V	SA	1
1-1	5		DA61-03467B	FIXER-HOSE; AW-PJT,HIPS,NATURAL,S834S1	SA	1
1-2	5	M0208	DA73-00211A	RUBBER-CAP HOSE; i4-PJT,SILICON,GRAY	SA	1
1-3	5	M0221	DA61-04195A	STOPPER-DOOR L; GUGGENHEIM,SHP1,T3.0	SA	1
1-4	5	M0265	DA66-00558B	CAM HINGE-RISER UPP L; POLARIS,PA66,BLACK	SA	1
2	2	G0573	DA97-12398F	ASSY-GASKET DOOR; FRE, HM10,GRAY,L1587,W3	SA	1
3	2		DA63-07278A	GUARD FRE-SUB; HM 12,PP,COOL WHITE	SA	1
4	2	M0139	DA67-03540A	CAP-CHUTE ICE; HM12,ABS,T1,HB,HG-0760GP,C	SA	1
5	2		DA63-07069A	GUARD-FRE TOP; HM12,GPPS,TP BLUE,HB,165N,	SA	1
6	2	M0365	DA63-07068A	GUARD-FRE LOW; HM12,GPPS,TP BLUE,HB,165N,	SA	2
7	2	G0282	DA97-12819A	ASSY COVER DISP; HM12,DISPENSER, EXP	SA	1
7-1	3		DA97-12811A	ASSY COVER DISP-SUB; HM12,ACRYL+ABS,ULTRA	SNA	1
7-1-1	4	M0027	DA63-07086A	COVER DISPENSER; HM12,ABS,Ebony Black	SNA	1
7-1-2	4		DA64-04247B	WINDOW-COVER DISPENSER; HM12,ACRYL,T3,MET	SNA	1
7-2	3	A0566	DA64-04242A	INLAY-DISPLAY; HM12-PJT,PET,T0.1,W134,L63	SA	1
7-3	3	G0069	DA92-00393A	ASSY PCB KIT LED; LED TOUCH DISPLAY,HM12,	SA	1
7-4	3	G0547	DA64-02982C	BUTTON-DISPENSER; HM09,ABS,NOBLE GRAY,VER	SNA	1
7-5	3	G0540	DA63-05058B	COVER-PBA PANEL DISPENSER; HM10,HIPS,NTR	SNA	1
8	2		DA97-12776A	ASSY COVER-PCB PANEL REAR; HM10,IN_DOOR	SNA	1
8-1	3	G0581	DA97-12836A	ASSY COVER-PCB PANEL REAR SUB; HM10,IN_DO	SA	1
8-1-1	4	G0532	DA63-03259C	COVER PCB-PANEL REAR; HM09,HM10,ABS,LIGHT	SNA	1
8-1-2	4	G0518	DA61-01616A	SPRING ETC-LEVER DISP WATER; AD,STS304,T0	SNA	1
8-1-3	4		DA61-01868B	BRACKET-OIL DAMPER; ABS,AD,-,-,-,NTR,-	SNA	1
8-1-4	4		DA61-01869A	OIL DAMPER; AD,PC+POM, 120g/Cm, , OD15	SNA	1
8-1-5	4	G0530	DA63-01972A	GASKET COVER; HM,SI,BLACK	SNA	1
8-1-6	4	G0529	DA63-01971B	COVER-ICE ROUTE B; AD,ABS,-,-,-,-,NATUR	SNA	1
8-1-7	4	M0216	DA61-01651A	SPRING ETC-COVER ICE ROUTE; AD,STS304,1.0	SNA	1
8-1-8	4	G0528	DA63-01970A	COVER-ICE ROUTE A; AD,ABS,T2.5,-,-,-,-,BL	SNA	1

No.	Lvl.	Loc.	Material Code	Description & Specification	SNA	Qty.
8-1-9	4	G0412	6002-000473	SCREW-TAPPING; TH,+,NO,1,M4,L14,PASS,STS3	SA	1
8-2	3		DA66-00685A	LEVER-DISPENSER WATER; HM09,SAN,NTR	SA	1
8-3	3		DA66-00684A	LEVER-DISPENSER ICE; HM09,SAN,NTR	SA	1
9	2	A0842	3405-001119	SWITCH-MICRO; 250VAC,1A,80,SPST-NO,T105	SA	2
10	2		DA97-05073Z	ASSY-HANDLE BAR REF; HERMES-PJT,-,MH/RS	SC	2
10-1	3	A0556	DA64-02442C	HANDLE-BAR; HERMES,Al,1633,INOX	SNA	2
10-2	3	M0062	DA67-01913A	CAP-HANDLE; HERMES,ABS,-,W20.8,L37.3,NEO	SNA	2
10-3	3	A0819	DA67-02009A	CAP-SUPT HANDLE; HERMES-PJT,ABS,-,MAN	SNA	8
10-4	3		DA61-03726A	SUPPORT-HANDLE; HERMES,PA66,-,NTR	SNA	8
10-5	3	M0062	DA67-01913B	CAP-HANDLE; HERMES,ABS,-,W20.8,L37.3,SILV	SNA	2
10-6	3		DA61-03636A	STOPPER-HANDLE; CULLINAN,SK5,T0.5	SNA	8
11	2		DA97-05529C	ASSY-BRACKET HANDLE; HREMES-PJT,SWCH10A,-	SA	8
11-1	3		DA61-03725B	BRACKET-HANDLE; HERMES,SWCH10A,-,L31,-,	SNA	8
11-2	3		DA63-03840A	GROMMET-HANDLE; HERMES,SI,T1,NTR,DISP, 40	SNA	8
12	2		DA97-05081G	ASSY-TRAY ICE BUCKET; HERMES-PJT,MSWR10	SA	1
12-1	3	M0193	DA66-00388B	LEVER-CUBE; HM,STS304,OD4.5 x L440	SNA	1
12-2	3	G0412	6002-000473	SCREW-TAPPING; TH,+,NO,1,M4,L14,PASS,STS3	SA	8

# 5. Fridge Door

## Exploded View

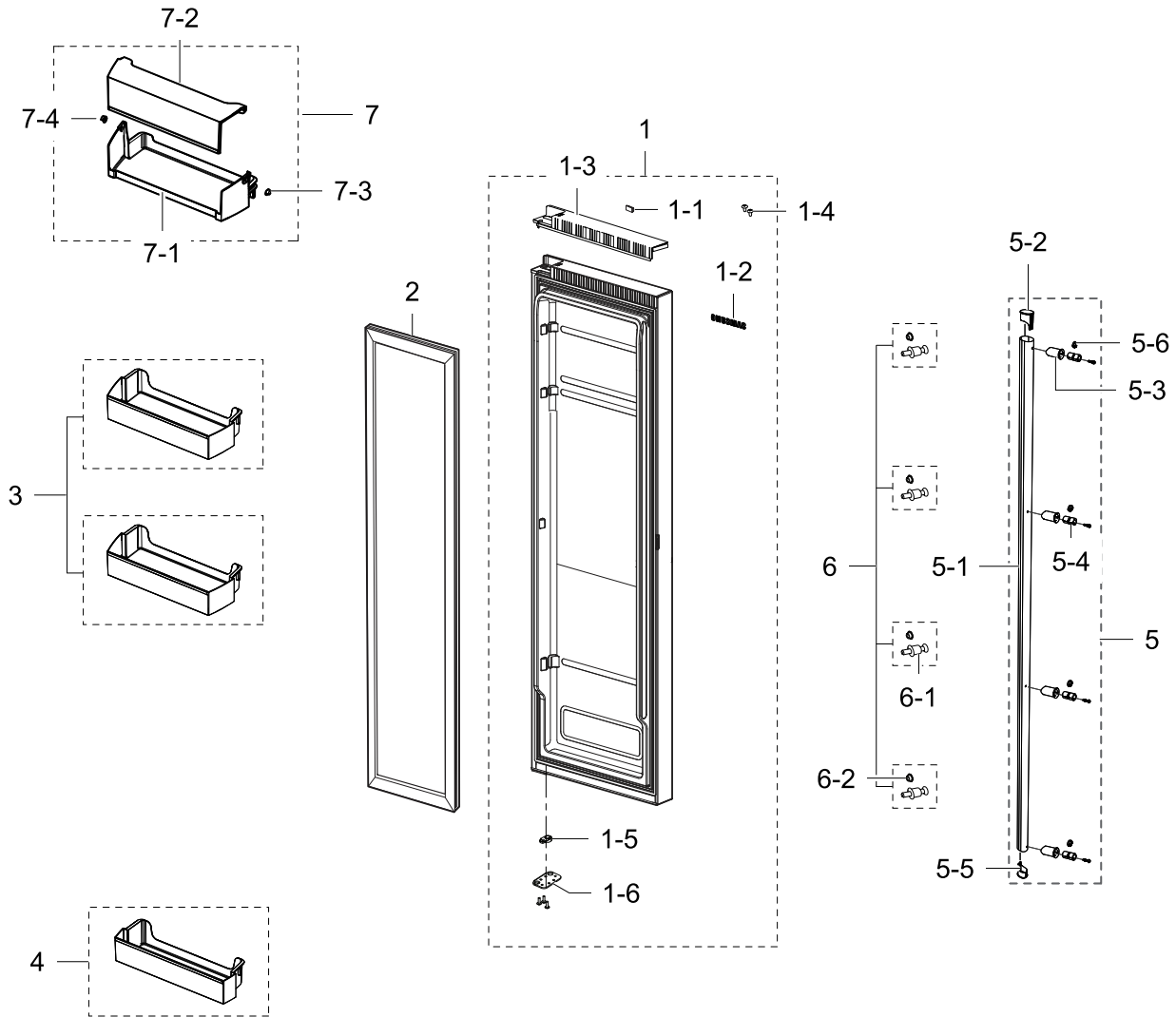

## Parts List

No.	Lvl.	Loc.	Material Code	Description & Specification	SNA	Qty.
1	2		DA91-03843G	ASSY DOOR-FOAM REF; RS756*/RS752*,ALF,V,L	SA	1
1-1	5	A0534	DA61-03769A	MAGNET-A; HERMES,FERRITE,1600Gauss	SNA	2
1-2	3	M0196	DA64-04021C	MASCOT; ALL,Ni,T0.06,L90	SA	1
1-3	4		DA97-12789D	ASSY CAP DOOR REF-UPP; HM10-SEPM,T2.5,W76	SA	1
1-4	3	G0412	6002-000239	SCREW-TAPPING; TH,+,NO,2S,M4,L8,ZPC(WHT),	SA	4
1-5	5	G0554	DA66-00557A	CAM HINGE-RISER UPP R; GUGGENHEIM,PA66,BL	SA	1
1-6	5	M0222	DA61-04196A	STOPPER-DOOR R; GUGGENHEIM,SHP1,T3.0	SA	1



No.	Lvl.	Loc.	Material Code	Description & Specification	SNA	Qty.
2	2	G0574	DA97-12398G	ASSY-GASKET DOOR; REF,HM10,GRAY,L1587,W46	SA	1
3	2		DA63-07067A	GUARD-REF TOP; HM12,GPPS,TP BLUE,HB,165N,	SA	2
4	2	M0369	DA63-07062A	GUARD-REF LOW; HM12,GPPS,TP BLUE,HB,165N,	SA	1
5	2		DA97-05073Z	ASSY-HANDLE BAR REF; HERMES-PJT,-,-,MH/RS	SC	2
5-1	3	A0556	DA64-02442C	HANDLE-BAR; HERMES,AI,1633,INOX	SNA	2
5-2	3	M0062	DA67-01913A	CAP-HANDLE; HERMES,ABS,-,W20.8,L37.3,NEO	SNA	2
5-3	3	A0819	DA67-02009A	CAP-SUPT HANDLE; HERMES-PJT,ABS,-,-,MAN	SNA	8
5-4	3		DA61-03726A	SUPPORT-HANDLE; HERMES,PA66,-,NTR	SNA	8
5-5	3	M0062	DA67-01913B	CAP-HANDLE; HERMES,ABS,-,W20.8,L37.3,SILV	SNA	2
5-6	3		DA61-03636A	STOPPER-HANDLE; CULLINAN,SK5,T0.5	SNA	8
6	2		DA97-05529C	ASSY-BRACKET HANDLE; HREMES-PJT,SWCH10A,-	SA	8
6-1	3		DA61-03725B	BRACKET-HANDLE; HERMES,SWCH10A,-,-,L31,-,	SNA	8
6-2	3		DA63-03840A	GROMMET-HANDLE; HERMES,SI,T1,NTR,DISP, 40	SNA	8
7	2	M0094	DA97-12780B	ASSY GUARD-DAIRY; HM12,GPPS,NTR	SA	1
7-1	3	A0155	DA63-07063A	GUARD-DAIRY; HM12,GPPS,TP BLUE,HB,147F,HI	SA	1
7-2	3	A0660	DA63-07070B	COVER GUARD-DAIRY; HM12,GPPS,HB,165N,TP B	SA	1
7-3	3		DA67-02920A	CAP-HINGE DAIRY R; HERMES,POM,NTR	SA	1
7-4	3		DA67-02921A	CAP-HINGE DAIRY L; HERMES,POM,NTR	SA	1