

Service Manual

Models: FRN-SH23BVW

Features

- Energy efficiency
- Micro foam technology
- Low noise operation
- Thick insulation for energy efficiency
- Latest No. 2 micro-biological technology

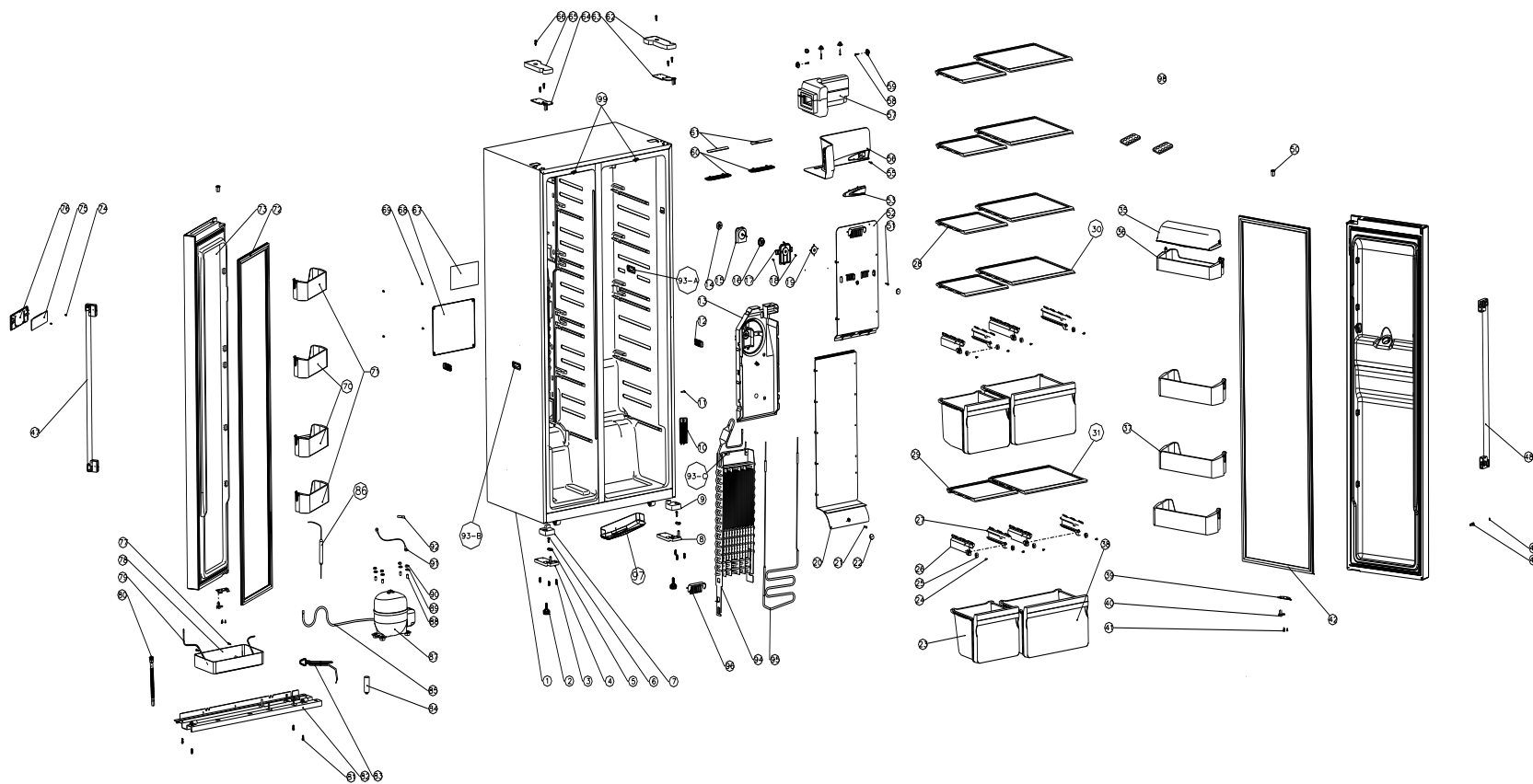

FRN-SH23BVS

No.	Parts code	Description of Spare Part	Quantity
1	2102250008	Cabinet	1
2	20122990593	Adjustable foot assembly	2
3	3060100078	Screw of M6*16	6
4	3031400140	Lower door hinge assembly,left	1
5	2208510016	Block of aid-closer,lower	2
6	3060100074	Screw of M6X16	2
7	2200450003	Cover of left hinge,lower	1
8	3031400138	Lower door hinge assembly,right	1
9	2200450002	Cover of right hinge,lower	1
10	20122990488	Return air respirator	1
11	3060100053	Screw ST4.2X13	1
12	20122990629	Thermal head cover	1
13	20122990491	Fan motor bracket	1
14	3029900265	Back rubber gaske of motor	1
15	3059900028	Fan motor parts with fan	1
16	3080100059	Front rubber gaske of motor	1
17	20122990495	Electrical installation cover	1
18	3060100053	Screw ST4.2X13	1
19	3029900272	Motor fan	1
20	20122990494	Front cover of Freezer wind tunnel parts,lower	1
21	3060100053	Screw ST4.2X13	1
22	20122990493	Screw cap	2
23	20122030507	Lower drawer	1
24	3060100058	Screw ST4.2X9.5	8
25	20122990484	Guide roller	8
26	20122990483	Left guide I	3
27	20122990485	Rjght guide I	3
28	2106100003	Shelf of freezer chamber,upper	4
29	3020500150	Shelf of freezer chamber,lower	1
30	2106100004	Shelf of refrigerator chamber,upper	4
31	3020500152	Shelf of refrigerator chamber,lower	1
35	20122050393	Upper rack cover of refrigerator	1

36	20122050391	Upper rack of refrigerator	1
37	20122050389	Lower rack of refrigerator	3
38	20122040292	Crisper drawer,lower	1
39	3039900184	Limit line iron	2
40	2208510015	Block of aid-closer,upper	2
41	3060100048	Screw ST4.2X13	6
42	3020400232	Door gasket,right	1
43	2100250114W	Door,right	1
44	3060100076	Screw	4
45	3060100083	Screw of M5*8	4
47	3039900292	Handle handle,Left	1
48	3039900292	Handle handle,Right	1
50	2208100018	Collar,upper	2
51	3060100053	Screw ST4.2X13	1
52	20122990492	Front cover of freezer wind tunnel parts,upper	1
53	20122990607	Deodorizer cover	1
55	3060100048	Screw ST4.2X13	1
56	20122990489	Front cover of refrigerator wind tunnel parts	1
57	2107120007	Foaming parts of refrigerator wind	1
57,1	3071000187	Refrigerator wind foam parts,upper	1
57,2	3071000188	Refrigerator wind foam parts,lower	1
57,3	3059900027	Damper motor of refrigerator wind	1
58	3060100055	Screw ST4.2X16	4
59	20122990482	Cover plate of fixed seat	4
60	20122010104	Cover of ceiling light	2
61	3050400018	Ceiling light	2
62	2208200006	Cover of right hinge,upper	1
63	3031400215W	Upper door hinge assembly,right	1
64	3031400214W	Upper door hinge assembly,left	1
65	2208200005W	Cover of left hinge,upper	1
66	3060100017	Screw of M5*16	6
67	3050300027	Control board	1
68	3039900180	Cover of control board	1
69	3060100048	Screw ST4.2X13	4

70	2207500448	Left rack	2
71	20122050395	Left rack	2
72	3020400231	Door gasket,left	1
73	2100250031W	Door,left	1
74	3060100040	Screw of 2.5*9.5	2
75	3050300039	Display circuit board	1
76	3029900334	Display panel	1
77	3060100048	Screw ST4.2X13	2
78	20122990481	Drain pan	1
79	20114010065	Evaporative condenser	1
80	3020600065	Drain pipe	1
81	3060100078	Screw of M6*16	4
82	20120080097	Compressor base support	1
83	3050100093	Power supply cord plug	1
85	20114070026	Connecting tube	1
86	3040500022	Drier filter	1
87	3040100342	Compressor parts	1
88	3060300001	Cowsh	4
89	3060300005	Pad	4
90	3060200002	Nut	4
91	3050200094	Earthing wire of compressor	1
92	3040600005	Process tube	1
93-A	3050200155	Temperature sensor	1
93-B	3050200155	Temperature sensor	1
93-C	3050200155	Temperature sensor	1
94	3040300056	Fin Evaperator	1
95	3050700013	Frost heater & fuse	1
96	3071000186	Foam of Fin Evaperator	1
97	3039900181	Fixed slot of heater	1
99	2501100002	Door switch	2
101	2700103132	Carton	1
		Totally Quantity:	