

Service Manual

Split System

Air Conditioner

Model: DSB-F1274LH-V

✓ Caution

: In this Manual, some parts can be changed for improving, their performance without notice in the parts list. So, if you need the latest parts information, please refer to PPL(Parts Price List) in Service Information Center.

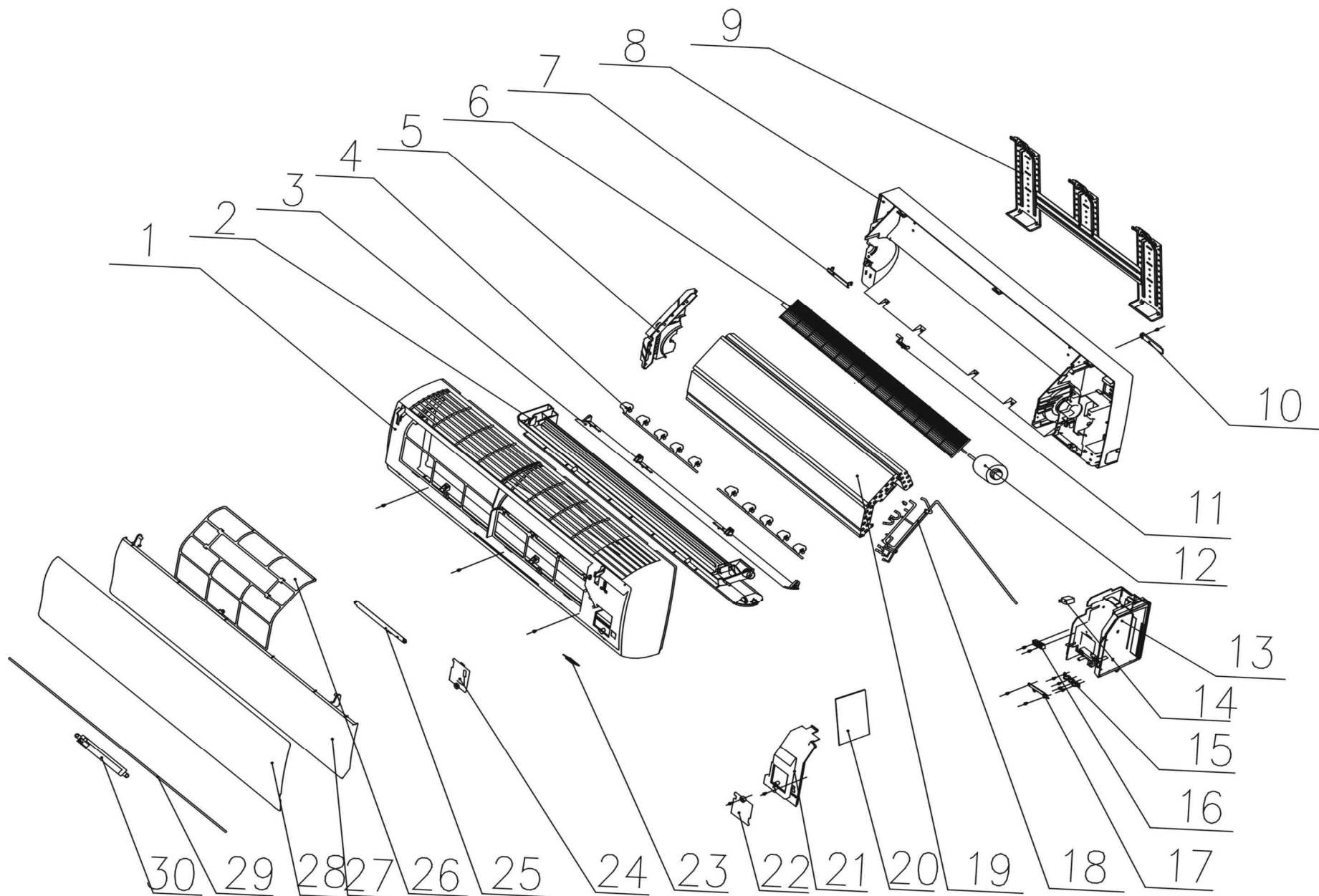

Part List of DSB-F1274(75)LH-V

Indoor Unit			
No.	CODE	English	Qty.
1	1806R000136	Medium frame	1
2	1644R000009	Air-vent holder	1
3	1843R000047	Louver / Horizontal air-blade	1
4	1843R000048A	Vertical air-blade assembly	10
5	1800R000050B	Left plastic-holder for evaporator	1
6	1500R000263A	Through-flow fan	1
7	1832R000092	Cover of chassis	2
8	1804R000051	Chassis	1
9	18040003000	Mounting plate	1
10	1543R000483	Pipe clamp	1
11	1502R000118A	Slip block	3
12	1515R000028	Indoor fan motor	1
13	1805R000064	Electric controller box	1
14	1804R000053	Transformer	1
15	1611Z000405A	Wire clamp	1
16	1813R000007	Terminal board	1
17	1831R000031	Signal receiver holder for remote controller	1
18	1543R000709A	Evaporator piping assembly	1
19	1557Z003232A	Evaporator assembly	1
20	11500162000	Main PCB	1
21	11112005301	Cover of electric controller box	1
22	11503001100	Connecting cover	1
23	11115000100	Receiver window for remote controller signal	1
24	11108006401	Wire-connecting cover of medium frame	1
25	18230000178	Indication lamp holder	1
26	1831R000053A	Filter	2
27	18320000478	Panel scale board	1
28	18310000278	Panel	1
29	1843R000709A	Mirror ornamental panel	1
30	1857Z003232A	Display board	1
31	15260000293B	Remote Controller	1

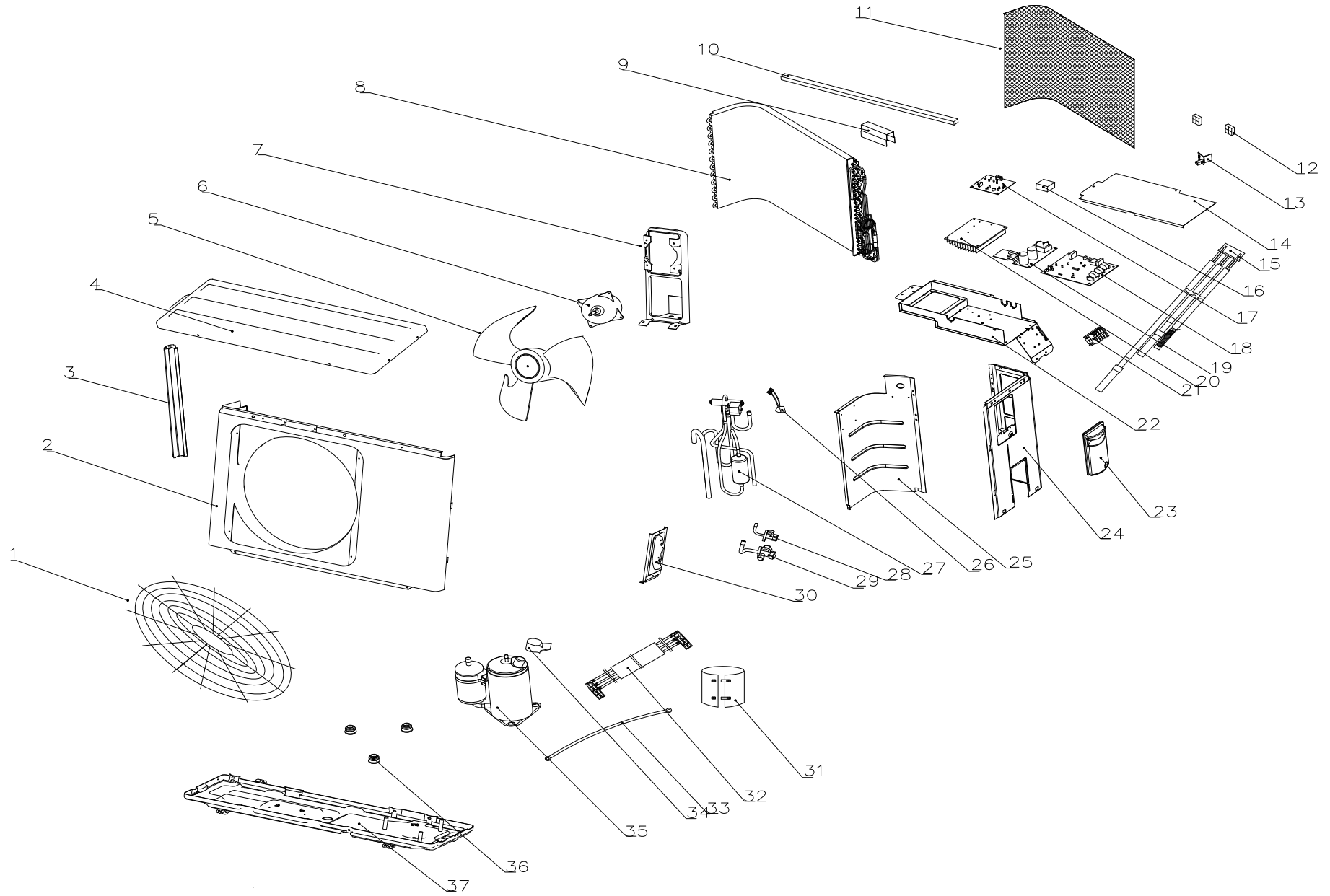

Outdoor Unit

No.	AUX CODE	English	Qty.
1	1833R000018A	Panel net	1
2	1806R000127	Panel	1
3	1843Z000005	Left . side support panel	1
4	1611Z000230A	Top cover	1
5	1804R000128A	Axial-flow fan	1
6	1543Z000215	Fan motor	1
7	1831R000035	Holder for electric motor	1
8	1815R000042D	Condenser assembly	1
9	1627R001300	Condenser clamp	1
10	1811R000200	Condenser sponge	1
11	16270000107	Back defense net	1
12	1804R000400E	Rubber block	2
13	1557Z001262	Temperature sensor bracket	1
14	1502R000054	Cover for electric unit	1
15	18318000301	Temperature sensors of ODU	1
16	18330001416	Commutation bridge	1
17	1806R000121	IPM modular	1
18	15450000205	Main control board	1
19	15453004400	PFC & reactance assembly	1
20	1815R000077A	Radiator	1
21	1545R000820A	Terminal board	1
22	15500000500	Holder for electric unit	1
23	1543R000926A	Handle	1
24	1545Z000016	Right side plate	1
25	1805R000180	Partition panel	1
26	16453004400	Magnetic coil	1
27	1615R000077A	Four way valve assembly	1
28	15458000411	Gas valve	1

29	1545Z000023	Liquid valve	1
30	16500000500	Valve plate	1
31	15430122400	Anti-acoustic sponge for compressor	1
32	1602R000054	Power connection cable for compressor	1
33	16318000301	Ground wire	1
34-- 36	18330001135	Compressor and accessories	1
37	1806R000058C	Chassis assembly	1